

Doctorat en Ciències Ambientals



Life Cycle Assessment as a Tool for Green  
Chemistry: Application to Different Advanced  
Oxidation Processes for Wastewater Treatment

Tesi Doctoral

Ivan Muñoz Ortiz

Bellaterra, març de 2006



Dr. XAVIER DOMÈNECH ANTUNEZ, Catedràtic del Departament de Química de la Universitat Autònoma de Barcelona,

i

Dr. SIXTO MALATO RODRÍGUEZ, Investigador Titular de OPI, Responsable de Detoxificación y Desinfección de Aguas del Centro de Investigaciones Energéticas, Medioambientales y Tecnológicas (CIEMAT),

CERTIFIQUEM:

Que la present memòria, titulada "*Life Cycle Assessment as a Tool for Green Chemistry: Application to Different Advanced Oxidation Processes for Wastewater Treatment*", ha estat realitzada sota la nostra direcció a la Unitat de Química Física del Departament de Química de la Universitat Autònoma de Barcelona pel llicenciat en Ciències Ambientals Ivan Muñoz Ortiz, i constitueix la seva tesi per optar al grau de Doctor en Ciències Ambientals.

I perquè així consti, signem el present certificat a Bellaterra, 1 de març de 2006.

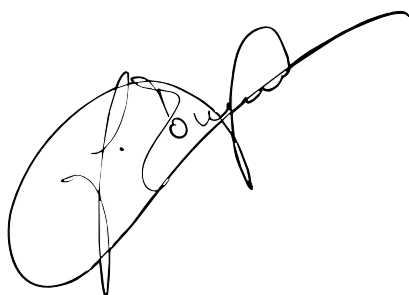

Dr. Xavier Domènech Antúnez



Dr. Sixto Malato Rodríguez



## CONTENTS

Acknowledgements/Agraïments/Agradecimientos .....	iii
Abbreviations .....	v
<b>CHAPTER 1. Objectives and Structure of the Study</b> .....	<b>1</b>
1.1. Problem Setting.....	2
1.2. Objectives .....	5
1.3. Structure and Outline of the Study .....	6
References to Chapter 1 .....	8
<b>CHAPTER 2. Green Chemistry: Concepts and Tools</b> .....	<b>9</b>
2.1. The Green Chemistry Framework.....	11
2.2. The Need to Measure “Greenness”.....	19
2.3. Review of Tools for Environmental Assessment .....	20
References to Chapter 2 .....	31
<b>CHAPTER 3. Advanced Oxidation Processes for Water and Wastewater Treatment</b> .....	<b>35</b>
3.1. Introduction .....	37
3.2. Heterogeneous Photocatalysis .....	40
3.3. Ozonation.....	45
3.4. Homogeneous Photocatalysis: Fenton and photo-Fenton .....	49
3.5. AOPs as “Green” Chemical Processes .....	53
References to Chapter 3 .....	57
<b>CHAPTER 4. Environmental and Economic Assessment by means of Life Cycle Tools</b> .....	<b>61</b>
4.1. Fundamentals of Life Cycle Assessment .....	63
4.2. LCA Applied to Chemical Products and Processes .....	69
4.3. Streamlined LCA.....	72
4.4. Life Cycle Costing .....	75
4.5. Integration of LCA and LCC .....	81
4.6. Previous Environmental Assessments of AOPs for Wastewater Treatment .....	87
References to Chapter 4 .....	89
<b>CHAPTER 5. Streamlined Life Cycle and Cost Assessment of different Advanced Oxidation Processes for Wastewater Treatment</b> .....	<b>95</b>
5.1. Goal and Scope .....	97
5.2. Inventory Analysis .....	110
5.3. Life Cycle Impact Assessment .....	113
5.4. Cost Assessment .....	120
5.5. Integration of Environmental Impact and Cost .....	122
5.6. Conclusions and Recommendations .....	124
References to Chapter 5 .....	127

Appendix 5.1. Life Cycle Impact Assessment tables.....	129
<b>CHAPTER 6. Life Cycle and Cost Assessment of a Coupled Advanced Oxidation-Biological Process for Wastewater Treatment.....</b>	<b>133</b>
6.1. The CADOX Project.....	137
6.2. Goal and Scope .....	144
6.3. Inventory Analysis for Baseline Alternatives .....	164
6.4. Life Cycle Impact Assessment for Baseline Alternatives .....	182
6.5. Sensitivity Analysis on Activated Carbon Production and Regeneration.....	187
6.6. Environmental Impact of Solar Photocatalysis as a Function of UV Light Available .....	192
6.7. Assessment of Measures for Environmental Improvement.....	196
6.8. Cost Assessment .....	205
6.9. Integration of Environmental Impact and Cost .....	216
6.10. Conclusions and Recommendations.....	220
List of symbols .....	227
References to Chapter 6.....	229
Appendix 1. Calculation of $Q_{UV}$ from pilot plant data .....	235
Appendix 2. Photovoltaic installation in a solar photocatalytic plant for wastewater treatment.....	237
Appendix 3. Estimation of solar photocatalytic plant dismantling cost .....	240
Appendix 4. Life Cycle Impact Assessment tables.....	242
<b>CHAPTER 7. Overall Discussion and Conclusions.....</b>	<b>247</b>
7.1. Discussion.....	248
7.2. Conclusions.....	256

## Acknowledgements/Agraïments/Agradecimientos

En primer lloc, moltes gràcies, Xavier, per haver-me permès realitzar amb tu aquesta tesi, oportunitat que valoro no només des del punt de vista acadèmic i professional, sinó sobretot per haver pogut participat del teu estil de treball, el secret del qual consisteix en facilitar les coses al màxim i posar les persones per davant de tot; crec que és una bona filosofia. Espero que encara ens quedin moltes excursions per fer.

Muchas gracias también a ti, Sixto, por abrirme las puertas de la Plataforma Solar de Almería y acogerme dentro del proyecto CADOX, permitiéndome con ello realizar la tesis. Ha sido de largo la experiencia más interesante de mi corta trayectoria profesional, ya que por primera vez verdaderamente he tenido la sensación de estar haciendo investigación. Espero que podamos seguir en contacto en el futuro.

Special thanks also to the whole CADOX staff, not only for providing all the data I needed and patiently assisting me, but also (and most important), for the great times in Almería, Barcelona, Lisboa, and Paris. Gracias a la gente de PSA: Nacho Maldonado, Isabel Oller, Wolfgang Gernjak, Julián Blanco y Pilar Fernández, por vuestra atención durante mi visita en Almería, así como durante el resto del tiempo. Gracias también a José Antonio Muñoz, de Deretil. Gracias a César Pulgarín, de EPFL, por intentar resolver mis quebraderos de cabeza con el tratamiento biológico de aguas. Je remercie aussi à Milena Lapertot, de l'EPFL, et à Florencio martin, de Trailigaz, mais surtout à Jean-Yves Perrot, de Trailigaz, par répondre toujours mes interminables doutes à propos de l'ozonation. Muito obrigado a Paula Passarinho, de INETI, e também a Joao Correia, de Ao Sol. Por último, una mención especial para la gente de Ecosystem: a Juan Pablo Vincent, y como no, a Martín Vincent, no solo por estar siempre dispuesto a ayudarme, sino por mostrar verdadero interés en mi trabajo. Debo añadir también aquí a personas que, aunque fuera del proyecto, me han ayudado de una forma u otra: Rafael Domínguez de MASA Decor, José Hernández, de Albaida, Christian Sattler, del Deutsches Zentrum für Luft- und Raumfahrt, and also Gabor Doka, from Doka Life Cycle Assessments, for helping me with his Ecoinvent models.

També agraeixo sincerament l'ajuda desinteressada de la Maria Martin, del LEQUIA de l'Universitat de Girona, per introduir-me en el món del carbó actiu i donar-me l'oportunitat de fer l'únic treball experimental que he dut a terme durant el doctorat. De veritat que no em posava la bata des que feia la carrera. També agraeixo l'ajuda de l'Anna Ros i la Teia Vives, per la seva inestimable ajuda durant el experiments.

De la mateixa manera, haig d'agraïr l'ajuda de diverses persones del Departament d'Enginyeria Química de l'Autònoma, tant professors com becaris, a l'hora de resoldre els meus dubtes sobre tractament biològic d'aigües residuals, en concret a Fco. Javier Lafuente, Julián Carrera, Albert Guisasola i Albert Bartrolí.

Voldria també mencionar aquí a en Joan Rieradevall, no només pel fet d'haver estat codirector de la tesina, sinó perquè de no haver-te conegut, Joan, probablement ni tan sols hagués començat el doctorat, per no mencionar la fructífera etapa d'almenys 4 anys en la qual vaig aprendre moltíssim.

I com podria oblidar la gent amb qui he conviscut els darrers anys a l'Autònoma? caldria començar per l'antic Centre d'Estudis Ambientals (CEA), on m'ho vaig passar de conya amb el David Colomer, el Pau Martí, la Laura Sáenz, la Mireia Fontcuberta, i com no, l'Anna Borfo; en guardo records molt bons. A poc a poc va anar apareixent més gent: l'Eli Roca (bé, de fet sempre hi has estat), l'Elena Domene, l'Oriol Gelizo, la Sigrid Muñiz, la Natàlia Núñez, l'Ignasi Puig, el Feliu López (què ho saps lo què...), la Sònia Sánchez, l'Anna Doroteo i la Loli García. Llavors el CEA es converteix en flamant Institut de Ciència i Tecnologia Ambientals (ICTA), i arriba l'explosió demogràfica (espero que hi sigueu tots i totes): Gonzalo Gamboa, Daniela Russi, Chus Ramos, Anna Llopart, Mireia Montes, Sílvia Canyellas, Javi Gómez

(siempre nos quedará Montjuïc), Roser Maneja, Montse Núñez, Xavi Cazorla, Saioa Elordui, Gregor Meerganz, Ester García, Nico Kosoy, Miguel Martínez, Iliana Monterroso, Pablo Muñoz (gracias por tu ayuda con la inflación y la tasa de descuento), Sílvia Mayo, Paula Bruna (bueno, tu también estabas desde antes), Frédérique Caille, Zeca Couto, Patrícia Jiménez, Lourdes Álvarez, Carles Martínez, Neus Puy, Rosa Binimelis, Roxana Bravo, Jordi Oliver, Marta Albet, Rafael Osorio i Raul García. Esteu ja tots? no, haig de afegir-hi els meus companys de fatigues en el grup d'ACV-ecodisseny-prevenió ambiental: l'Alba Bala, la Cristina Gazulla, i el gran Llorenç Milà, el meu veritable mestre en l'art de l'ACV.

Cal afegir unes quantes persones més, durant la meva darrera etapa en el doctorat, què he passat molt a gust a la Unitat de Química Física, amb el grup del Xavier: Pepe Peral (con la tesis otro jamón, ya lo sabes), José Antonio Ayllón (que tio más pesao), las super nenas Maribel Franch, M<sup>a</sup> José Farré i Julia García; Xavi Batlle, David Gutiérrez, Nilbia Ruiz i Anna Serra. Cal afegir els companys d'electroquímica Gonzalo Guirado, Mustafa El Hauzi i Neus Vila, així com a la Rosa Calzada. En el fons els químics sou bona gent.

Creo que estaría bien añadir un apartado de miscelánea, en el que voy a agradecer, en primer lugar, a los técnicos de informática, principalmente a Pedro y Olaya, por el incontable número de veces que me han resuelto problemas con el ordenador, llámense virus, errores de redundancia cíclica, y otros aún más incomprensibles. También estaría bien agradecer la existencia de diccionarios en la red, que han facilitado a alguien como yo redactar una tesis en inglés. Agradezco también que los esclavos negros de Brasil inventaran hace siglos la capoeira, un arte cuyo descubrimiento me ha aportado una válvula de escape y me ha permitido evadirme un poco de la química verde, el ACV y los AOPs durante el último año y pico; muchas gracias por tanto a mi profesor Lau y a mis compañeros Guti, Mão no bolso, y Pica-Pau (Pica, gracias por los precios de lámparas UV). Una mención especial también merecen aquellas personas que saben escuchar y comprenderme; tu, Patricia, estás por encima de todos; creo que nadie me conoce tan bien.

Mi último reconocimiento es, como no podía ser de otra manera, para mi familia. Para mis padres, y no solo porque sin ellos no estaría ahora delante del ordenador escribiendo, sino por su apoyo incondicional (que suena a tópico, pero es que es verdad...), y para mi hermano, porque en el fondo los polos opuestos se atraen.

Gracias a todos,

Ivan Muñoz Ortiz

Bellaterra, 1 de marzo de 2006



## Abbreviations

1,1,1-TCA	1,1-trichloroethane
1,1-DCA	1,1-dichloroethane
AIChE	American Institute of Chemical Engineers
AOPs	Advanced Oxidation Processes
AP	Acidification Potential
ASTM	American Society for Testing and Materials
BAT	Best Available Technique
BEES	Building for Environmental and Economic Sustainability
CADOX	A Coupled Advanced Oxidation-Biological Process for Recycling of Industrial Wastewater Containing Persistent Organic Contaminants
CEFIC	European Chemical Industry Council
CFCs	Chlorofluorocarbons
CH	Switzerland
CIEMAT	Centro de Investigaciones Energéticas, Medioambientales y Tecnológicas
COD	Chemical Oxygen Demand
CPC	Compound Parabolic Collector
CWRT	Center for Waste Reduction Technologies
DE	Deutschland
DOC	Dissolved Organic Carbon
EBCT	Empty Bed Contact Time
EC	Energy Consumption
EC <sub>50</sub>	Effective Concentration for 50% population to be affected
ECF	Elemental Chlorine Free
EEA	European Environment Agency
EEF	Eco-efficiency Factor
EER	Econo-environmental return
EIPPCB	European Integrated Pollution Prevention and Control Bureau
ELC	European Lamp Companies Federation
EMPA	Swiss Federal Laboratories for Materials Testing and Research
EP	Eutrophication Potential
EPER	European Pollutant Emission register
EPFL	École Polytechnique Fédérale de Lausanne
ERPA	Environmentally Responsible Product Assessment Matrix
EU	European Union
FU	Functional Unit
GAC	Granular Activated Carbon
GDP	Gross Domestic product
GLO	Global
GWP	Global Warming Potential
HPLC-UV	High Performance Liquid Chromatography with UV detector
IARC	International Agency for Research on Cancer
IBR	Immobilized Biomass Reactor
ICAEN	Institut Català de l'Energia
ICChemE	Institution of Chemical Engineers
IDAE	Instituto para la Diversificación y Ahorro de Energía
IEA	International Energy Agency
IEC	International Electrotechnical Commission
INETI	Instituto Nacional de Engenharia e Tecnologia Industrial
IPCC	Intergovernmental Panel on Climate Change
IPPC	Integrated Pollution Prevention and Control
ISO	International Organization for Standardization
LCA	Life Cycle Assessment

LCC	Life Cycle Costing
LCI	Life Cycle Inventory
LCIA	Life Cycle Impact Assessment
LC-IC	Liquid Chromatography – Ion Exchange Chromatography
LCM	Life Cycle Management
LD <sub>50</sub>	Lethal Dose for 50% population death
LEQUIA	Laboratori d'Enginyeria Química i Ambiental
LPG	Liquefied Petroleum Gas
MRI	Midwest Research Institute
MWWTP	Municipal Wastewater Treatment Plant
NBCS	Non-Biodegradable Chlorinated Solvents
NOAEL	Non Observed Adverse Effects Level
NPV	Net present Value
ODP	Ozone Depletion Potential
OECD	Organisation for Economic Co-operation and Development
ORP	Oxidation Reduction Potential
PCE	Perchloroethylene
PHS	Priority Hazardous Substances
PSA	Plataforma Solar de Almería
PZC	Point of Zero Charge
REPA	Resource and Environmental Profile Analysis
RER	Europe
SETAC	Society of Environmental Toxicology and Chemistry
SPOLD	Society for the Promotion of Life-cycle Development
TCA	Total Cost Assessment
TCE	Trichloroethane
TCF	Total Chlorine Free
TOC	Total Organic Carbon
UAB	Universitat Autònoma de Barcelona
UCTE	Union for the Coordination of Transmission of Electricity
UNCED	United Nations Commission on Environment and Development
UNEP	United Nations Environment Program
UNEP-IE	United Nations Environment Program – Industry and Environment Centre
UPC	Universitat Politècnica de Catalunya
USEPA	United States Environmental Protection Agency
UV	Ultraviolet
UV-A	Ultraviolet radiation in the range 315-400 nm
UV-B	Ultraviolet radiation in the range 280-315 nm
UV-VIS	Ultraviolet/visible light
VOC	Volatile Organic Compound
WBCSD	World Business Council for Sustainable Development
WMO	World Meteorological Organisation
WWTP	Wastewater Treatment Plant

# CHAPTER 1.

## Objectives and Estructure of the Study

---

*"A journey of a thousand miles begins with a single step."*

*Confucius*

### CONTENTS

1.1. Problem Setting.....	2
1.1.1. The environmental impact of chemistry.....	2
1.1.2. Sustainable development and Green Chemistry.....	3
1.1.3. Measuring sustainability of chemical processes.....	4
1.2. Objectives .....	5
1.3. Structure of the Study .....	6
References to Chapter 1 .....	8

The first chapter of this thesis aims at presenting the context, purpose, and the overall structure of the work. First of all, the environmental impact of the chemical industry, and the challenge of achieving sustainability through the design of environmentally benign chemicals and chemical processes are outlined, as well as the need for environmental tools to support decision making in this context. After this introduction, the objectives of the thesis are presented, and finally the methodology and structure of the study are summarised.

## 1.1. Problem Setting

The development of chemistry during the twentieth century has changed our lives. In fact, chemistry and chemicals surrounds us in our daily activities, due to the huge supply of products aimed at improving our quality of life. Chemistry has resulted in the medical revolution of the past century, in which drugs such as antibiotics have been used to cure diseases that affected mankind for centuries. These advances have led to the rise in the average life expectancy from 47 in 1900, to 75 years in the 1990s (Breslow 1997). On the other hand, the world's food supply has seen an explosive expansion because of the development of pesticides as well as fertilisers that protect crops and improve their productivity. Other common chemicals are those related to hygiene, such as soaps, detergents, disinfectants, toothpaste, etc. Therefore, there is practically no facet in material life – transportation, communication, clothing, shelter, office – in which chemistry does not play an important role, either to supply consumer products or to improve services addressed to society in general (Domènech 2005).

In spite of all these clear benefits, the chemical industry is often viewed by the general public as causing more harm than good (Lancaster 2002). A major reason for this is that the industry is perceived as being polluting and causing significant environmental damage. Indeed, the manufacture, use and disposal of chemicals consume large amounts of resources, and originates emissions of pollutants to all environmental compartments, not to mention the numerous accidents and disasters in which the chemical industry has been involved in the recent past.

### 1.1.1. The environmental impact of chemistry

The chemical industry is essentially a transforming one, turning raw materials into basic chemicals, which in turn are either consumed or used to obtain other compounds with higher added value. Thus the global processing can be constituted by several stages, in which losses of materials and energy occur, and low yields give rise to dissipation, fugitive emissions to the environment and wastes. The chemical sector is responsible of 7% of the world's energy consumption, and this amount originates mainly from non-renewable energy sources (IEA 2000). According to the European Pollutant Emission Register (EPER 2004) this is the industrial sector contributing most to the emissions of several pollutants to the atmosphere, namely HFCs, N<sub>2</sub>O, dichloromethane, dichloroethane, tetrachloromethane, trichlorobenzenes, trichloroethane, trichloroethylene and trichloromethane. Its contribution to discharges to water recipients are also critical for mercury, nitrogen, phosphorus, arsenic, fluoride, dichloroethane, hexachlorobenzene and hexachlorobutadiene. According to the Toxics Release Inventory, in 2002 the U.S. chemical industry released to air, water and land, more than 507,000 tonnes of chemicals (USEPA 2003). However, this inventory keeps track of about 600 substances, only a small fraction of the approximately 75,000 substances in commercial use today (Anastas and Warner 1998).

The public concern over how chemical substances may cause harm to human health and the environment appeared in the late 1950s and early 1960s, when Rachel Carson's *Silent Spring* (Carson 1962) was published, detailing the effects of certain pesticides on the eggs of various birds, and the problem of biomagnification through the food chain. Also in 1961 there was a scare in Europe about the unexpected teratogenic effects of thalidomide, a drug used by pregnant women to lessen the effects of nausea and vomiting. As a result of taking thalidomide, more than 8,000 children were born worldwide with accute birth effects, such as missing or deformed limbs (Annas and Elias 1999). Yet another very famous case of environmental impact of industrial pollution is the poisoning caused by eating contaminated fish in Minamata bay, Japan, where mercury discharged to the bay from an adjacent chemical facility was accumulated and biomagnified in fish, resulting in the death of more than 100 people and the paralysis of thousands since 1956.

Apart from the unexpected effects of chemical products in human health and the environmental impact of diffuse pollution, the occurrence of accidents is also at the core of the perception of the chemical industry as a threat for the public. Events such as the accident in Bhopal, India, in 1984, wherein approximately 41 tonnes of methyl isocyanate were released at night from a Union Carbide's factory, provoking the death of over 3,000 people and serious after-effects to over 300,000 (Gupta 2002), or the accident at Seveso, Italy, in 1976, where a toxic cloud containing about 30 kg of dioxin was released from a chemical plant (Mocarelli 2001), have contributed significantly to this view.

All these examples are of unforeseen environmental consequences, resulting in legislation to control the manufacture, use and disposal of chemical substances. However, industry-related environmental policy was originally intended only to control emissions at the end of the pipe, and as we have seen through the years, although necessary, this approach is insufficient in stopping progressive environmental degradation and also lacks flexibility for an evolving industry (Sonneman et al. 2004). Instead, environmental considerations must be included in the entire range of industrial management, meaning that environmental impact must be considered within all phases of production, marketing, use and end of life once a product's life is over (Sonneman et al. 2004).

### 1.1.2. Sustainable development and Green Chemistry

The global demand of chemical products will keep growing in this century, and in the mid term this demand is expected to increase even faster than the world's population and GDP (OECD 2001). From these facts, it is clear that for this growth not to entail an environmental threat, a shift towards a more efficient and sustainable chemistry is needed.

The term "sustainable development" is generally attributed to the United Nations Commission on Environment and Development (UNCED), which published in the mid 1980s the so-called "Brundtland Report", that defined sustainable development as: "... meeting the needs of the present without compromising the ability of future generations to meet their own needs" (UNCED 1987). Sustainability takes into account three basic imperatives (Robinson and Tinker 1997):

- *"the ecological imperative is to stay within the biophysical carrying capacity of the planet,*
- *the economic imperative is to provide an adequate material standard of living of all, and*
- *the social imperative is to provide systems of governance that propagate the values that people want to live by".*

The concept of sustainable development generated criticism from the beginning due to its vagueness (Robinson 2004), but it has been accepted by governments, NGOs, society in general and industry sectors as the starting point for the world to make progress toward becoming a safer planet, not only for us, but for the generations to come. Although there is not an agreed answer to the question of how much waste or pollution can we safely release to the environment, there is a general agreement on the need to dematerialize the economy (WBCSD 1999; Robinson 2004) and to reduce pollution at the source (Lancaster 2002; Anastas and Warner 1998), so that quality of life can be ensured while living within the carrying capacity of supporting ecosystems (Chambers et al. 2000).

The response of the chemical industry to the challenge of sustainable development appears with the concept of Green Chemistry, which was coined by the US Environmental Protection Agency in the early 1990s and can be defined briefly as the use of chemistry for pollution prevention. In more detail, it is aimed at designing chemical substances and production processes respectful of the environment, by reducing or eliminating the use of dangerous substances. It encompasses all aspects and types of chemical processes such as synthesis, catalysis, analysis, monitoring, reaction separators and conditions (Sonneman et al. 2004). Although this approach is of special interest to the chemical industry,

it holds many parallelisms with other concepts or strategies for environmental management, such as Eco-efficiency, Industrial ecology, Cleaner Production or Design for the Environment.

### 1.1.3. Measuring sustainability of chemical processes

As we see, the challenge for the chemical industry in the twenty-first century is to continue to provide the benefits we have come to rely on, in an economically viable manner, but without the adverse environmental side effects (Lancaster 2002). Green Chemistry offers an appropriate framework for achieving sustainability through its 12 principles (Anastas and Warner 1998), but it also poses significant barriers. One of the major barriers is the lack of comprehensive evidence of good environmental and economic performance of proposed green chemical processes (Lapkin et al. 2004). This is exactly the starting point of this thesis, that is, the need for Green Chemistry to incorporate quantitative tools that allow decision making on the greenness of new chemical processes, and it is proposed that in order to capture all the relevant information on greenness, a life cycle approach is required, for both environmental and economic issues.

## 1.2. Objectives

As introduced in the previous section, this thesis is concerned with the suitability of a quantitative life cycle approach to measure the sustainability of chemical processes. Life Cycle Assessment (LCA) is suggested as an appropriate tool to provide such information, and Life Cycle Costing (LCC) as a convenient complement to LCA in order to capture economic performance. The usefulness of LCA will be evaluated in two case studies dealing with Advanced Oxidation Processes (AOPs) for wastewater treatment, an emergent group of technologies that claim to be designed under the principles of Green Chemistry.

Keeping all this in mind, the following objectives have been derived:

1. Contribute to the acceptance of LCA as quantitative instrument in the framework of Green Chemistry and pollution prevention, thus serving as a tool to assess the sustainability of new products, processes and technologies.
2. Apply this tool to a group of chemical processes still under development, namely the advanced oxidation of industrial wastewaters containing persistent organic compounds, in order to assess the environmental impact of the the different treatment options available.
3. Complement the LCA case study with an economic assessment based on LCC, proposing a convenient method to integrate the environmental and economic information obtained, in order to facilitate decision making.
4. Finally, to check the effect of the scale of analysis – from laboratory to full-scale plant – on the applicability of the tool and on the quality of the results.

### 1.3. Structure and Outline of the Study

This work is structured in 7 chapters. Chapters 2 to 4 constitute the theoretical framework of the thesis, while in chapters 5 and 6 two case studies are developed. Finally, chapter 7 corresponds to the general discussion and conclusions.

Chapter 2 starts by introducing the concept of Green Chemistry: its origin, methods, applications, and its relationship with other concepts for environmental management. From this presentation, a criticism is made to this approach of pollution prevention on the basis of its qualitative nature, thus highlighting the need to introduce in this theoretical framework quantitative tools for assessing the progress made by applying green chemistry practices on products and processes. Finally a review of tools currently used for environmental assessment is carried out – LCA among them – and their potential usefulness for decision support in Green Chemistry is discussed.

Chapter 3 introduces the object under assessment in the thesis, namely AOPs. The three main technologies subject to environmental assessment in chapters 5 and 6 are presented: heterogeneous photocatalysis, ozonation, and Fenton and photo-Fenton processes. The fundamental mechanisms, advantages and drawbacks, as well as the state of the art of these three AOPs is depicted. Subsequently, a discussion is made on the “greenness” of these AOPs when compared to other technologies for wastewater treatment, highlighting the need of a quantitative tool to accomplish this purpose. At this point, taking into account the tools reviewed in chapter 2 and attending to the type of assessment to be done, LCA is finally suggested as an appropriate tool.

Chapter 4 aims to introduce the tools used in the thesis to assess AOPs: LCA as well as LCC. First, LCA is described from a methodological point of view, highlighting its applications in the chemical sector, and the possibility to use streamlining methods to make the tool more suitable during the early stages of product and process development. LCC, the economic counterpart of LCA, is then introduced. As opposed to LCA, LCC is not yet a standardized tool in the framework of sustainability assessment, and for this reason different cost accounting concepts and methodological approaches are discussed, specially with regard to how LCA and LCC must be integrated. Finally, a review is made on previous environmental assessments of AOPs through the use of LCA.

In chapter 5 a first attempt to assess different AOPs by means of a streamlined LCA is made, along with a simple cost assessment. The study is based on data acquired through laboratory experiments carried out on a bleaching kraft mill wastewater, which is treated by heterogeneous photocatalysis, photo-Fenton, ozonation as well as some combinations of these processes. Two scenarios are considered concerning the source of photons to run the AOPs: solar energy and UV lamps.

The interest on this case study lies on the laboratory scale at which it is carried out, since this is the most basic stage of development of chemicals, where Green Chemistry principles has its core. The application of LCA is intended to test its usefulness as a tool for chemists interested in finding out the relative greenness of chemical products and processes.

The study identifies the most significant issues from an environmental point of view, and compares the different AOP treatments. However, several difficulties are recognized when applying LCA as well as cost assessment at this scale, mainly from lack of optimization of the conditions at which the chemical processes take place, as well as to the uncertainty and lack of data with regard to a full-scale application. It is concluded that LCA can be useful in this context, but the question remains of to which extent the results obtained are reliable, something that can be answered with the help of chapter 6.



In chapter 6 a full LCA and LCC is carried out to evaluate the technology in development by the european CADOX project, consisting on the coupling of AOPs with biological treatment for the detoxification of wastewaters containing persistent organic chemicals. Data derived mainly from pilot plant and full-scale plants are used, permitting a more precise and complete study, which is interesting for several reasons: first, because AOPs are evaluated more accurately and closer to real work conditions; second, this accuracy allows to compare AOPs with conventional technologies already applied to full scale. Another reason is that measures for environmental improvement can be suggested in more detail, as the wastewater treatment plant is already designed or even physically exists. Finally, the results can serve either to validate or to refute the conclusions of the screening carried out in Chapter 5, therefore providing arguments to discuss whether LCA as a tool is reliable or not, at the bench scale.

Several techniques evaluated at the laboratory scale in Chapter 5, namely heterogeneous photocatalysis, photo-Fenton and ozonation are once again evaluated in chapter 6, but including the coupling of these to a biological treatment in a conventional sewage treatment plant. Activated carbon adsorption is chosen as reference technology to which the AOPs are compared. A detailed LCA and LCC is performed, which allows to compare all the alternatives, and to propose and evaluate several measures for environmental improvement of photo-Fenton and ozonation treatment plants. Also sensitivity analyses are carried out concerning the data used for GAC production and regeneration, and concerning influence on impacts and cost of the intensity of UV light in solar-driven photo-Fenton plants.

This chapter also includes the definition of an Eco-efficiency Index, that allows to integrate in a simple way environmental and economic performance, obtaining a single eco-efficiency score by which all the alternatives under study can be ranked.

Chapter 7 is constituted in first place by a discussion on the reliability of laboratory-derived LCAs, supported by the results obtained in chapters 5 and 6 on the subject of AOPs. Based on this, the suitability of LCA as a tool for Green Chemistry is also discussed as well as the appropriateness of LCC as a complement for LCA in this context. Finally, the chapter ends with a summary of the conclusions reached in the thesis.

## References to Chapter 1

- Anastas P, Warner J. 1998. *Green Chemistry Theory and Practice*. Oxford University Press. Oxford.
- Annas G J, Elias S. 1999. *Thalidomide and the Titanic: reconstructing the technology tragedies of the twentieth century*. American Journal of Public Health, 89 (1) p. 98.
- Breslow R. 1997. *Chemistry today and tomorrow*. American Chemical Society, Washington, DC.
- Carson R. 1962. *Silent Spring*. Mariner Books. New York.
- Chambers N, Simmons C, Wackernagel M. 2000. *Sharing Nature's Interest. Ecological Footprints as an indicator of sustainability*. Earthscan Publications Ltd, London, UK.
- Domènech X. 2005. *Química Verde*. Rubes Editorial, Barcelona.
- EPER. 2004. *EPER Review Report*. European Commission. [www.eper.cec.eu.int/eper/](http://www.eper.cec.eu.int/eper/)
- Gupta J P, 2002. *The Bhopal gas tragedy: could it have happened in a developed country?*. Journal of Loss Prevention in the Process Industries, 15 (1), pp. 1-4.
- IEA. 2000. *Energy Balances of OECD Countries and Energy Balances of Non-OECD Countries, 1971-1998*. IEA Secretariat. Paris.
- Lancaster M. 2002. *Green Chemistry An introductory Text*. RSC Paperbacks, UK.
- Lapkin A, Joyce L, Crittenden B. 2004. *Framework for evaluating the "greenness" of chemical processes: case studies for a novel VOC recovery technology*. Environmental Science and Technology, 38, pp. 5815-5823.
- Mocarelli P. 2001. *Seveso: a teaching story*. Chemosphere, 43 (4-7), pp. 391-402.
- OECD. 2001. *Environmental Outlook for the Chemicals Industry*. OECD Environment Directorate, Paris.
- Robinson J, Tinker J, 1997. *Reconciling ecological, economic, and social imperatives: a new conceptual framework*. In: Schrecker, T. (Ed.). *Surviving Globalism: Social and Environmental Dimensions*. Macmillan, St. Martin's Press, London, New York, pp. 71– 94.
- Robinson J. 2004. *Squaring the circle? Some thoughts on the idea of sustainable development*. Ecological Economics, 48, pp. 369-384.
- Sonneman G, Castells F, Schuhmacher M. 2004. *Integrated Life-Cycle and Risk Assessment for Industrial Processes*. Lewis Publishers, Florida, USA.
- UNCED. 1987. *Our Common Future*. Oxford University Press, Oxford.
- USEPA. 2003. *Toxic Release Inventory*. [www.epa.gov/tri/](http://www.epa.gov/tri/)
- WBCSD. 1999. *Eco-efficiency indicators and reporting, technical report*. Working Group on Eco-Efficiency Metrics & Reporting. Geneva, Switzerland.

# CHAPTER 2.

## Green Chemistry: Concepts and Tools

---

*“One ploy of green chemistry is to work more like Mother Nature. Plants, for example, have access only to air, a few trace minerals in the soil and energy from the sun, yet they carry out hugely complex chemical transformations”.*

*Paul T. Anastas*

*“I often say that when you can measure what you are speaking about, and express it in numbers, you know something about it; but when you cannot measure it, when you cannot express it in numbers, your knowledge is of a meagre and unsatisfactory kind”.*

*Lord Kelvin*

### CONTENTS

6.1. The Green Chemistry Framework .....	11
6.1.1. Origins and Definition .....	11
6.1.2. The 12 Principles.....	12
6.1.2.1. Prevention .....	12
6.1.2.2. Atom economy.....	12
6.1.2.3. Less hazardous chemical syntheses .....	13
6.1.2.4. Designing safer chemicals.....	13
6.1.2.5. Safer solvents and auxiliaries.....	13
6.1.2.6. Design for energy efficiency .....	13
6.1.2.7. Use of renewable feedstocks .....	14
6.1.2.8. Reduce derivatives .....	14
6.1.2.9. Catalysis .....	14
6.1.2.10. Design for degradation .....	14
6.1.2.11. Real-time analysis for pollution prevention .....	15
6.1.2.12. Inherently safer chemistry for accident prevention .....	15
6.1.3. Related concepts.....	15
6.1.3.1. Green Engineering .....	16
6.1.3.2. Cleaner production .....	17
6.1.3.3. Eco-efficiency .....	17
6.1.3.4. Industrial Ecology .....	17
6.1.3.5. Ecodesign.....	17
6.1.3.6. Life Cycle Thinking .....	17
6.2. The Need to Measure “Greenness”.....	19
6.3. Review of Tools for Environmental Assessment .....	20
6.3.1. Indicators.....	20

6.3.1.1. Resource intensity indicators.....	20
6.3.1.2. Environmental impact indicators.....	23
6.3.2. Site-oriented methods.....	24
6.3.2.1. Environmental Auditing.....	25
6.3.2.2. Environmental Impact Assessment.....	25
6.3.2.3. Risk Assessment.....	25
6.3.3. Chain-oriented methods.....	26
6.3.3.1. Material intensity per Service unit.....	26
6.3.3.2. Sustainable Process Index.....	26
6.3.3.3. Exergy-based Sustainability.....	27
6.3.3.4. Substance Flow Analysis.....	27
6.3.3.5. Life Cycle Assessment.....	28
6.3.4. Suitability of reviewed tools in the Green Chemistry framework.....	28
References to Chapter 2.....	31

This chapter introduces the concept of Green Chemistry, an approach conceived in the 1990s aiming at conciliating the development of chemicals and environmental protection, by using a set of principles for pollution prevention. The objective of this chapter is to give an overview of this approach, its practical applications, and most important for this thesis, to highlight the need for this framework to incorporate methods that allow the quantification of environmental improvements and trade-offs resulting from Green Chemistry practices. A critical review of tools for environmental assessment is carried out, in order to make manifest whether they are appropriate or not to assess the “greenness” of chemical processes and products.

## 2.1. The Green Chemistry Framework

During decades, the emissions and wastes generated by the industry have been dealt with just by dumping them into the various environmental compartments (atmosphere, continental and sea waters, land), taking advantage of their dilution capacity. Subsequently, the environmental laws regulated the amount of pollutants that could be released into a particular receiving stream, promoting abatement technologies and confinement of final waste; but these end-of-pipe solutions are partial and get more and more expensive, as regulations become more stringent. As a consequence, the focus has recently been displaced to prevention, as the ultimate way of avoiding pollution and waste. It is in this context that the concept of Green Chemistry appears.

### 2.1.1. Origins and Definition

In the United States, the Pollution Prevention Act of 1990 established source reduction as the highest priority in solving environmental problems. Passage of this act signaled a move away from the end-of-pipe response and toward a more effective strategy that focused on preventing waste in the first place (Anastas and Kirchhoff 2002). Shortly after the passage of the Act it was recognized that a variety of disciplines needed to be involved in source reduction. This recognition extended to chemists, the designers of molecular structures and transformations. In 1991, the Office of Pollution Prevention and Toxics in the USEPA launched the first research initiative in this field, the Synthetic Pathways Research Solicitation, and in 1993 the program officially adopted the name "U.S. Green Chemistry Program".

With regard to Green Chemistry activities in Europe, during the first half of the 1990s, both Italy and the UK launched major initiatives in Green Chemistry, establishing research and education programs. In 1999 the journal *Green chemistry* appeared, sponsored by the Royal Society of Chemistry. Also in the second half of the decade, Germany and the Czech Republic started also Green Chemistry activities, and finally a proposal for a *European Green and Sustainable Chemistry Award* has been made (Astrup Jensen 2001)

Green chemistry has been defined by Anastas et al. (2000) as:

*"The design of chemical products and processes that reduce or eliminate the use and generation of hazardous substances"*.

For the purposes of this definition, the use of the term "chemistry" is used in its formal definition as applying to the structure and transformation of all matter, making the applicability extremely broad. The methods and techniques of Green Chemistry address environmental issues at the design stage, and at the most fundamental level, i.e. the molecular level, dealing with the intrinsic rather than the circumstantial properties of a product or process. Another clarification in the above definition is the term "hazardous". The hazards addressed in this definition include the full range of threats to human health and the environment. This includes, but is not limited to, toxicity, physical hazards (explosions, fires), global climate change, and resource depletion (Anastas and Lankey 2000).

Green Chemistry differs from previous approaches to environmental protection in several ways (Anastas and Lankey 2001; Anastas and Warner 1998; Lancaster 2002a; Domènech 2005):

- It addresses hazard rather than exposure. Risk is a function of hazard and exposure. The traditional way that industry and society has dealt with the reduction of risk is through the reduction of exposure (engineering control,

personal protective equipment, etc.). Instead, Green Chemistry pursues as final goal the reduction of hazard, by substituting or minimizing toxic by non-toxic substances.

- It is economically driven rather than economically draining. By means of prevention, significant savings can be made, arising from reduced raw material use and avoidance of waste treatment and pollution removal.
- It is non-regulatory. Green chemistry encourages innovation, and the environmental authorities work with the industry through partnership, a completely voluntary type of activity.
- It prevents problems before they occur through avoidance approaches. Green Chemistry is basically an approach to addressing the environmental consequences of products or processes at the design stage.
- It considers the full life cycle impacts at the design stage. Green Chemistry is not only concerned with the properties of new chemicals, but also with the indirect consequences of the product through manufacture, distribution, use and disposal.

## 2.1.2. The 12 Principles

In conjunction with the American Chemical Society, the USEPA developed Green Chemistry into a set of 12 guiding principles (Anastas and Warner 1998), which are described in this section. These principles are a categorization of the fundamental approaches taken to achieve the goal of pollution prevention, and are becoming widely accepted as a universal code of practice (Lancaster, 2002b).

### 2.1.2.1. Prevention

*"It is better to prevent waste than to treat or clean up waste after it is formed".*

In the past 20 years, the cost of treatment and disposal of chemical substances has become of significant importance, and the more hazardous the substance is, the more costly its management results. The only way to prevent these costs is to avoid the use or generation of hazardous substances. One type of waste that is both common and often the most avoidable is starting material that is not incorporated in the final product: when one wastes starting material, one is paying for the substance twice; first as feedstock and then as waste, and often the cost of waste management is many times the cost of the raw material.

### 2.1.2.2. Atom economy

*"Synthetic methods should be designed to maximize the incorporation of all materials used in the process into the final product".*

The classic evaluation of the effectiveness and efficiency of a synthesis is "yield", a concept that ignores the use or generation of any undesirable products in the reaction, since it is based on mole accounting. If a mole of reactant produces a mole of desired product, then the yield is 100%, even when simultaneously one or more moles of waste are generated per mole of product. The atom economy concept (Trost 1991) looks into how much of the reactants end up in the final product. An ideal reaction would incorporate all the atoms of the reactants, thus avoiding the generation of waste. The atom efficiency of the reaction is calculated as the ratio of the molecular weight of the product to the sum of the molecular weights of all the materials generated in the process. Some examples of improved atom efficiency in synthetic chemistry can be found in Clark (1999).

### 2.1.2.3. Less hazardous chemical syntheses

*“Wherever practicable, synthetic methodologies should be designed to use and generate substances that possess little or no toxicity to human health and the environment”.*

The fundamental basis of Green Chemistry is the incorporation of hazard minimization or elimination into all aspects of chemistry. There are only two ways to minimize risk of harm of any kind: either minimize the exposure or minimize the hazard. Only focusing on exposure has the first disadvantage of the cost that control equipment entails, and second, that exposure controls can fail, increasing the risk commensurately with that failure. On the other hand, hazard is an intrinsic characteristic that is not going to change and therefore the risk will not increase spontaneously. A practical application of this principle in the paper industry is the use of hydrogen peroxide as a substitute of chlorine dioxide, in order to avoid chlorinated by-products in bleaching effluents (Collins et al. 2002).

### 2.1.2.4. Designing safer chemicals

*“Chemical products should be designed to preserve efficacy of function while reducing toxicity”.*

This area of Green Chemistry aims at maximizing the desired performance and function of the chemical product while ensuring that the toxicity and hazard is reduced to its lowest possible level. There are several approaches to design safer chemicals: If a certain reaction is essential for the toxic mechanism to take place, a structural change could be made to ensure that the reaction does not occur. When the exact mechanism is not known, but there is still a correlation between chemical structure and the toxic effect, the functionality related to this effect can be avoided or minimized. Yet another strategy is to minimize bioavailability, by changing properties such as polarity and water solubility. A practical example of toxicity reduction while maintaining performance is the substitution of broad-spectrum insecticides by synthetic pheromones, which are non-toxic, and specific to the target species (Anastas et al. 2000b).

### 2.1.2.5. Safer solvents and auxiliaries

*“The use of auxiliary substances should be made unnecessary wherever possible and innocuous when used”.*

An auxiliary substance can be defined as one that aids in the manipulation of a chemical, but is not an integral part of the molecule itself. In the case of solvents, there are a number of concerns associated with them. According to the International Agency for Research on Cancer (IARC 2005), halogenated solvents such as methylene chloride, chloroform, perchloroethylene, etc. are suspected human carcinogens, while aromatic solvents like benzene are demonstrated carcinogens. Other environmental problems caused by solvents, and not directly linked to human health are the depletion of the stratospheric ozone by chlorofluorocarbons (CFCs), or the implication of volatile organic compounds (VOCs) in the formation of smog. Therefore, the use of benign auxiliaries is of vital importance in Green Chemistry. Existing alternatives are immobilized solvents and supercritical carbon dioxide (USEPA 1996), aqueous systems (Anastas and Williamson 1998), or even, to use no solvent at all (Clark et al. 2002).

### 2.1.2.6. Design for energy efficiency

*“Energy requirements should be recognized for their environmental and economic impacts and should be minimized. Synthetic methods should be conducted at ambient temperature and pressure”.*

Energy requirements of chemical reactions frequently are overlooked at the R&D stage and, for all but the largest commodity processes, were not considered seriously at the production stage until the oil crisis of the 1970s. As energy

has become more expensive and legislative drivers have promoted greater energy efficiency, improvements have been achieved in process design. However, it is often left to the process engineer to adjust and optimize these energy requirements, whereas it is only through the design of the reaction system that they can be fundamentally changed. An illustration of design for energy minimization is the use of catalysts in polymerization processes (USEPA 1996).

#### 2.1.2.7. Use of renewable feedstocks

*“A raw material or feedstock should be renewable rather than depleting whenever technically and economically practicable”.*

There is a growing consensus on the fact that, at least as far as oil is concerned, if we continued to use resources at the current rate we will face a significant shortage sometime in the second half of this century (Campbell and Laherrere 1998). The two main arguments for reducing our dependency on fossils and increasing our use of renewable feedstocks are: 1) to conserve energy supply for future generations, and 2) to reduce global emissions of greenhouse gases. Renewable feedstocks are mainly associated with biological and plant-based starting materials, which are already highly oxygenated and eliminate the need for the polluting oxygenating step. Furthermore, syntheses can be significantly less hazardous as compared to petroleum derived feedstocks. One of the most well-known applications in this field are starch-based polymers (Bastioli, 1998).

#### 2.1.2.8. Reduce derivatives

*“Unnecessary derivatization (blocking groups, protection/deprotection, temporary modification of physical/chemical processes) should be avoided whenever possible”.*

In chemical synthesis it is often required either to protect a sensitive functional group from an undesired reaction, to add a functional group in order to enhance selectivity, or to convert a compound to its salt in order to facilitate separation. However, these actions should be avoided since they imply additional steps and an increase in requirements of energy, time, as well as reagents. An example of eliminating the need of protection and deprotection is the use of enzymes in the synthesis of the antibiotic Penicillin (Sheldon 1994).

#### 2.1.2.9. Catalysis

*“Catalytic reagents (as selective as possible) are superior to stoichiometric reagents”.*

Catalysis offers advantages over stoichiometric reactions in terms of both selectivity and energy minimization. By driving the reaction to a preferred product, the amount of undesired by-products is decreased, thereby reducing waste generation. The amount of energy required for a given transformation is also reduced as the catalyst decreases the activation energy of the reaction. On the other hand, a catalyst will carry out thousands or more transformations before it is exhausted. A wide range of green catalysis applications can be found in Anastas et al. (2000b, 2001)

#### 2.1.2.10. Design for degradation

*“Chemical products should be designed so that at the end of their function they break down into innocuous degradation products and do not persist in the environment”.*

Traditionally, chemicals have not been designed accounting for the effect they would have when their useful life is over. As a result, several chemicals, such as plastics and pesticides, which are designed for long durability, remain in the



environment in the same form, posing a risk to organisms due to direct exposure or bioaccumulation. Therefore, the fate of chemical products must be a priority in product design, and biodegradability should be considered as an additional requisite. As for principle 7, starch-based plastics (Bastoli 1998) constitute a good example of designing biodegradable chemicals.

#### 2.1.2.11. Real-time analysis for pollution prevention

*“Analytical methodologies need to be further developed to allow for real-time, in process monitoring and control prior to the formation of hazardous substances”.*

This principle is based on the premise that “you cannot control what you cannot measure”. Having a continuous feedback is critical in order to optimize the conditions of a process. From an environmental point of view, there are several ways in which real-time monitoring can be useful: first, by controlling the generation of hazardous by-products; when toxic substances are detected it may be possible to change the process parameters. Secondly, monitoring the progress of a reaction allows to prevent from using excess reagents. An example of application by means of the use of gas chromatography can be found in USEPA (1998).

#### 2.1.2.12. Inherently safer chemistry for accident prevention

*“Substances and the form of a substance used in a chemical process should be chosen to minimize the potential for chemical accidents, including releases, explosions, and fires”.*

The occurrence of serious chemical accidents in the past (see chapter 1), teaches us about the need to address potential hazards such as toxicity, explosivity, and flammability, when designing products and processes. As the probability of accidents cannot be completely eliminated, it is desirable to use the most benign substances available, in order to minimize the environmental effects of an eventual release. An example of this approach is the process developed by Dupont to produce methyl isocyanate without the use of the highly toxic gas phosgene (Manzer 1994).

### 2.1.3. Related concepts

The establishment in the 1990s of sustainable development as a goal for society, has led to the appearance of several concepts for environmental management, which look for strategies different than just complying with environmental regulations. These concepts aim at achieving sustainability by introducing environmental considerations in human activities in general, being Green Chemistry the specific response of the chemical industry in this context. In this section the most common and accepted concepts are introduced (table 2.1), emphasizing the similarities and differences between them and Green Chemistry. As can be seen, the underlying philosophy is the same in all of them, and only differences on methodology, scale of application or target user, among others can be found (figure 2.1).

Table 2.1. Definition of related concepts to Green Chemistry for environmental management.

Concept	Definition
Green Engineering	Green engineering is the design, commercialization, and use of processes and products, which are feasible and economical while minimizing pollution at the source and risk to human health and the environment (Kirchhoff 2003).
Cleaner Production	Cleaner Production is the continuous use of an integrated and preventive environmental strategy, applied to processes, products and services to increase the eco-efficiency and reduce risks to the population and the environment (Rigola 1998).
Eco-efficiency	Eco-efficiency is achieved by the delivery of competitively priced goods and services that satisfy human needs and bring quality of life, while progressively reducing ecological impacts and resource intensity throughout the life cycle, to a level at least in line with the Earth's estimated carrying capacity (WBCSD 1993).
Industrial ecology	An integrated systems-perspective examination of industry and environment which conceptualizes the industrial system as a producer of both products and wastes, and examines the relationship between producers, consumers, other entities and the natural world (Sagar and Frosch 1997).
Ecodesign	Designing products minimizing their direct and indirect environmental impacts at every possible opportunity (Lewis et al. 2001).
Life Cycle Thinking	Life Cycle Thinking is a way of addressing environmental issues and opportunities from a system or holistic perspective. This way of thinking involves evaluating a product or service with the goal of reducing potential environmental impacts over the entire life cycle (Sonneman et al. 2004)

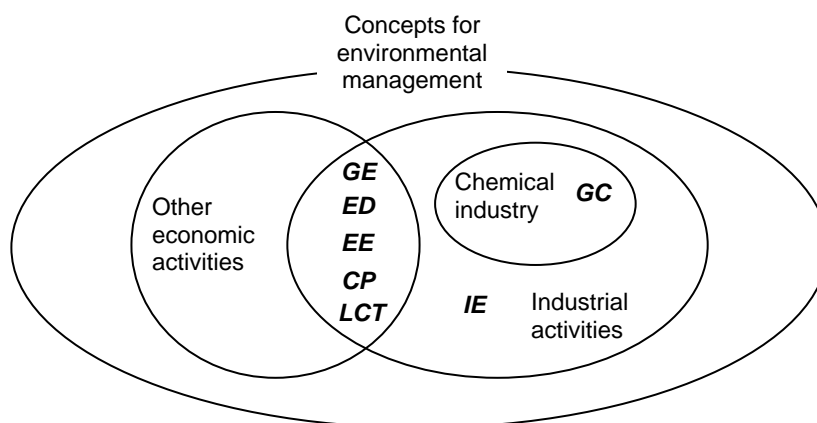

Figure 2.1. Relationship between Green Chemistry and other concepts for environmental management. GC: Green Chemistry, GE: Green Engineering, ED: Ecodesign, EE: Eco-efficiency, IE: Industrial Ecology, CP: Cleaner Production, LCT: Life Cycle Thinking.

### 2.1.3.1. Green Engineering

From the list in table 2-1, perhaps Green Engineering is the closest approach to Green Chemistry, since this concept has been developed by the same authors, and even a set of 12 principles has also been defined as a practical framework (Anastas and Zimmerman 2003; McDonough et al. 2003). Just like Green Chemistry, Green Engineering claims to address environmental problems at the design stage and through the entire life cycle of processes and products. Nevertheless, Green Chemistry focuses on the molecular scale and on the environmental implications of chemical reactions, while Green Engineering has a broader focus (Brennecke 2004), being the potential users not only chemists and chemical engineers but designers and engineers in general, regardless of whether they design molecules, materials, components, products or complex systems.

### 2.1.3.2. Cleaner production

Cleaner Production is an industry-related concept, although from its definition it can be seen that it can be applied not only to processes but also to products and services. This concept was first introduced by UNEP-IE (United Nations Environment Programme, Division of Industry and Environment) in 1989 (Rigola 1998). In the same line as Green Chemistry and Green Engineering, Cleaner Production aims at preventing pollution before it is produced, either at the production site or in the process chain. According to UNEP-IE, Cleaner Production and Eco-efficiency can be considered as synonymous; the slight difference is that while Eco-efficiency is based on aspects of economic efficiency that have environmental benefits, Cleaner Production is based on aspects of environmental efficiency that have economic benefits (UNEP-IE 2004).

### 2.1.3.3. Eco-efficiency

The term Eco-efficiency was first coined by Stephan Schmidheiny and coworkers (Füssler 1999), and was later defined by the World Business Council for Sustainable Development (WBCSD) in 1993, after the Rio summit. Eco-efficiency is understood by the WBCSD as a management strategy that links financial and environmental performance to create more value with less ecological impact, through optimized processes, waste recycling, eco-innovation, new services, and creation of networks and virtual organizations (WBCSD 2005). Among other business sectors, the chemical industry has adopted Eco-efficiency as a management philosophy. Some examples are companies such as Dow, Dupont and Basf.

### 2.1.3.4. Industrial Ecology

The aim of Industrial Ecology is to minimize waste generation and negative environmental impacts of industrial systems (Graedel 1994), by analysing them as natural systems, where materials and energy flow through a closed cycle: in the same way that waste from an organism is picked up as food by another organism, energy and materials wasted by an industrial process can be used as inputs to another process. This philosophy has been put into practice in the so called Eco-industrial parks, such as the one in Kalundborg, Denmark (Ehrenfeld and Gertler 1997). Industrial Ecology differs from the other pollution prevention approaches – like Green Chemistry, for example – in the networking aspect. While pollution prevention is assumed to be carried out more or less autonomously by industrial units, Industrial Ecology relies more on the relationship between units, requiring cooperative networks of actors (Jackson 2001). Nevertheless, Green Chemistry is also considered as a tool for Industrial Ecology (Anastas and Breen 1997).

### 2.1.3.5. Ecodesign

Ecodesign, also called Design for Environment, means environmentally conscious product development and design. Environmental aspects are included in the product planning, development, and design process at the earliest possible opportunity (Tischner et al. 2000). Life cycle thinking is a fundamental pillar of Ecodesign, since the environmental impacts of the product's life cycle have to be identified and minimized. Ecodesign is closely related to Green Engineering, and also to Green Chemistry. In fact, Green Chemistry can be considered as Ecodesign applied to chemical products and processes.

### 2.1.3.6. Life Cycle Thinking

LCA has been recognised not only as an analytical environmental management tool, but also as a concept (SPOLD 1995). This concept helps us to understand the overall environmental implications of the services required by society. Life Cycle Thinking reflects the acceptance that key societal factors cannot strictly limit their responsibilities to those phases of a life cycle in which they are directly involved. It expands the scope of their responsibility from the cradle to the

grave of the product, process or activity. Several approaches for environmental management discussed above consider Life Cycle Thinking as a key concept, Green Chemistry among them. According to Graedel (1999), adding a life-cycle perspective to Green Chemistry enlarges its scope and enhances its environmental benefits.

## 2.2. The Need to Measure “Greenness”

In the last section several concepts for environmental management have been presented, the goal of which is to progress towards sustainability. According to De Smet et al. (1996), concepts are ideas from specific professional disciplines on how to achieve sustainability. Concepts in turn are supported by tools in order to measure progress toward sustainability. Tools are defined as something that typically consists of a systematic step-by-step procedure, as well as a computational algorithm (a numerical model). Just like the other concepts, Green Chemistry is considered to fit in this framework, thus needing tools to objectively quantify environmental progress.

As we have seen, the backbone of Green Chemistry is constituted by a set of principles covering a wide range of environmental issues. This set of principles is therefore the main tool this approach offers to chemists and chemical engineers, in order to move from conventional to “green” chemical products and processes. Although these principles are useful as a starting point to define strategies for improvement, their qualitative nature can lead to some difficulties, in particular when the progress made by introducing Green Chemistry practices has to be measured (Eissen and Metzger 2002; Curzons et al. 2001; Lancaster 2002; Lapkin et al. 2004; Sikdar 2003; Winterton 2001; Gonzalez and Smith 2003). An example proposed by Domènech et al. (2002) considers the evaluation of how greener is a synthetic process involving a higher atom economy (principle 2).

Another problem the chemist has to face concerning the use of the 12 principles is the possibility of their application resulting in trade-offs. Anastas and Warner (1998) illustrate this issue through the comparison of stoichiometric and substoichiometric reagents: principle 9 promotes catalysts over stoichiometric reagents; however, the substoichiometric alternative may be more toxic than the stoichiometric pathway, something that would go against principle 3. It is clear that a priority of principles can not be generalized, and that sometimes trade-offs can not be avoided, but the chemist has to be able to assess in an objective way whether these trade-offs between principles lead to a net environmental improvement or not.

The scientific community has noticed this limitation of Green Chemistry; as a consequence, several methods for environmental assessment have been proposed in the last years, differing in focus, data requirements and applicability (Hellweg et al. 2004). An overview of these methods is presented in the next section.

## 2.3. Review of Tools for Environmental Assessment

The following review includes, in general terms, tools for environmental assessment. Three groups of tools have been considered: the first group corresponds to environmental indicators, considered as the most simple and readily available way of measuring “greenness”. The second and third group corresponds to tools for which are more complex from a methodological point of view, divided in two perspectives: site-oriented and chain-oriented methods.

### 2.3.1. Indicators

An indicator can be defined as a numerical measure used to show the progress toward achieving a specified outcome. According to Lapkin (2002), a group of indicators selected in order to characterise a complex phenomenon constitute a metric. However, the term metric is also found in the literature to refer to single indicators (Sikdar 2003; Constable et al. 2002). Yet another related term is index. This is usually referred to as the result of aggregating different indicators in a single score (Lapkin 2002; Krotscheck and Narodslawsky 1996).

One of the approaches suggested to measure “greenness” of chemical processes and products is to define a system of metrics, that is, a set of indicators under which the alternatives studied are assessed (Dewulf and Langenhove 2005; Lapkin et al. 2004; Jiménez-González et al. 2002). In this section a review of indicators for Green Chemistry is carried out, classified in two categories: resource intensity and environmental impact.

#### 2.3.1.1. Resource intensity indicators

Most of the indicators developed on the issue of resources deal with mass and energy intensity, although also water and land use are usually included. Table 2.2 summarizes the main indicators proposed.

Indicators based on mass intensity are defined here as those measuring the amount of material inputs and/or material outputs (waste) involved in a chemical process, per mass unit of the desired product. As can be seen, these indicators have been developed specifically for their use in synthetic chemistry, either at the laboratory or industry level. They have in common the objective of showing to what extent a chemical reaction is wasteful in material terms, being simplicity their main merit, as most of them can be easily calculated as soon as the chemical reaction is defined and quantified. However, they include neither information on energy issues nor on the toxicity or hazard associated with the inputs used and the waste produced. Another question for the chemist or chemical engineer is which indicator from this set to choose. As they are easy to calculate, a group of indicators – although not necessarily all of them – could be used to compare different pathways for a chemical to be produced. This would be preferable to using a single indicator, since more information is obtained. On the other hand, different indicators can lead to different (conflicting) results, as shown by Constable and coworkers (2002) who checked 28 chemical reactions against yield, atom economy, carbon efficiency, RMI, MI and mass productivity.

Since the oil crisis of the 1970s, energy has been an issue of concern, first for economic reasons and later for its environmental implications. Most of the commercial energy sources currently used are non-renewable and their conversion processes are rather polluting. Therefore, less energy-intensive processes are more sustainable (Lapkin 2002). Table 2.2 show several energy intensity indicators proposed for their use in process chemistry. Process energy and Solvent recovery energy are indicators focusing mainly on the level of the chemical reaction, while Primary energy usage, developed by the Institution of Chemical Engineers (IChemE), is more industry-oriented. As can be seen, the

latter may be calculated with respect to the economic value of the product, in line with the Eco-efficiency concept, which is defined as a ratio of economic and environmental performance (EEA 1999).

As it has been discussed for mass intensity indicators, energy intensity indicators, as they are defined in table 2.2 are simple to calculate, but give only a partial overview of “greenness”, as processes outside the chemical reaction or the chemical plant are not included. In addition, no discrimination is made between renewable and non-renewable sources, which have very different implications with regard to sustainability. Finally, the energy intensity related to material production (reactants, solvents, etc.) neither is included. As a consequence, energy intensity indicators must always be accompanied of material intensity indicators, which are measured in different units and can not be directly aggregated.

Table 2.2. Resource intensity indicators.

Mass			
Name	Definition	Units	Description
Atom economy	$= \frac{\text{MW product} \times 100}{\text{MW all reagents}}$	%	The atom economy concept (Trost 1991) calculates how much of the reactants remain in the final product of a chemical transformation. The method ignores reaction yield and molar excess of reactants, neither accounts for solvents and reagents (Constable et al. 2002).
Effective Mass Yield (EMY)	$= \frac{\text{Mass product} \times 100}{\text{Mass non-benign reagents}}$	%	Percentage of mass of desired product relative to the mass of all non-benign materials used in its synthesis (Hudlicky et al. 1999). Benign are those reagents or solvents with no environmental risk associated, such as water, dilute ethanol, etc.
E factor	$= \frac{\text{Mass waste}}{\text{Mass product}}$	kg/kg	The E factor quantifies the mass of waste generated per mass of product (Sheldon 1994, 1997). The specific hazard posed by different waste types is not taken into account.
Mass intensity (MI)	$= \frac{\text{Total mass}}{\text{Mass product}}$	kg/kg	Total mass of material inputs per mass unit of desired product (Curzons et al. 2001). Total mass includes everything used in the process with the exception of water: reactants, reagents, solvents, catalysts, etc. In an ideal situation, MI would be 1 (Constable et al. 2002).
Mass productivity	$= \frac{\text{Mass product} \times 100}{\text{Total mass reagents}}$	%	Mass productivity (Constable et al. 2002) is the inverse of MI, expressed as percentage, in a similar form to EMY and atom economy.
Reaction Mass Efficiency (RME)	$= \frac{\text{Mass isolated product} \times 100}{\text{Total mass reagents}}$	%	RME calculates the mass of reagents incorporated in the final product, expressed as percentage. Solvents, catalysts, etc. are not taken into account (Constable et al. 2002).
Carbon efficiency	$= \frac{\text{Mass carbon in product} \times 100}{\text{Total mass carbon in reagents}}$	%	Percentage of carbon in the reagents that remain in the final product (Constable et al. 2002). It can be considered as an equivalent for RME based on carbon accounting.
Energy			
Name	Definition	Units	Description
Process energy	$= \frac{\text{Total process energy}}{\text{Mass product}}$	MJ/kg	Amount of energy consumed in a chemical reaction per mass unit of product (Curzons et al. 2001).
Solvent recovery energy	$= \frac{\text{Total solvent recovery energy}}{\text{Mass product}}$	MJ/kg	Amount of energy consumed for recovery of solvents used during a chemical reaction, expressed per mass unit of product (Curzons et al. 2001).
Primary energy usage	$= \frac{\text{Total fuel energy}}{\text{Mass product}}$	MJ/kg	Amount of primary energy inputs consumed, either per mass unit of product or per unit value added (ICChemE 2002). Electricity and steam must be converted into primary energy by means of efficiency figures not provided by the authors.
	$= \frac{\text{Total fuel energy}}{\text{Value Added}}$	MJ/€	
Other resources			
Name	Definition	Units	Description
Water use	$= \frac{\text{Water used}}{\text{Mass product}}$	kg/kg	Takes into account water used in process, cooling and other purposes, expressed per mass unit of product (ICChemE 2002).
	$= \frac{\text{Water used}}{\text{Value added}}$	kg/€	Takes into account water used in process, cooling and other purposes, expressed per unit value added (ICChemE 2002).
Land use	$= \frac{\text{Land occupied}}{\text{Value added}}$	m <sup>2</sup> /year/€	Takes into account land occupied by operating unit for all activities, and other land indirectly affected, such as for mining or dumping of waste, per unit value added (ICChemE 2002).

MW: Molecular weight.



### 2.3.1.2. Environmental impact indicators

Environmental impact indicators are defined in this work as those intended to characterise and aggregate the contribution of a given set of inputs and/or outputs to environmental impact, being the latter understood as a general concept, or a particular problem such as climate change, toxicity, etc. These indicators are more elaborated than those on resource intensity, since not only the inputs and outputs have to be identified and quantified, but also an impact function describing the unfriendliness of those inputs and outputs, and which allows their aggregation has to be defined.

Table 2.3. summarizes several environmental impact indicators. On the one hand, the environmental quotient and EATOS focus on the impact of synthetic processes, by assigning impact scores to the raw materials used (environmental quotient case) or to both reagents and waste produced (EATOS case). These impact scores can be defined according to upstream and downstream effects of the material in question, meaning that a life cycle approach is addressed. However, these methods fail to include energy use, an indicator that would have to be measured separately. On the other hand, the IChemE indicators, similar to those developed by the American Institute of Chemical Engineers (AIChE) (CWRT 2002) and the European Environment Agency (EEA 1999), are developed mainly to be applied at the industry level, for monitoring and benchmarking, using economic value to measure products or services. Another difference is that while EATOS and the environmental quotient summarize environmental impact as a general attribute, expressed by potential environmental impact/environmental unfriendliness factors, IChemE indicators measure particular environmental problems, such as toxicity or acidification. This problem-oriented approach used by IChemE seems to be based on the Life Cycle Impact Assessment framework developed in the LCA methodology, as will be seen in chapter 4.

Table 2.3. Environmental impact indicators.

Name	Definition	Units	Description
Environmental quotient	$= \sum EU_i \times \frac{\text{Mass waste}_i}{\text{Mass product}}$	EU/kg	An extension of the E factor shown in table 2.2, the environmental quotient (Sheldon 1994, 1997) assigns an environmental unfriendliness (EU) factor to each kind of waste (i) produced. The amount of waste (i) produced is multiplied by its corresponding factor and the contribution of each waste is aggregated. An example of application can be found in Heinzle et al. (1998) and Koller et al. (1998).
Environmental assessment tool for organic syntheses (EATOS)	$= \sum PEI_i \times \frac{\text{Mass reactant}_i}{\text{Mass product}} + \sum PEI_i \times \frac{\text{Mass waste}_i}{\text{Mass product}}$	PEI/kg	EATOS (Eissen and Metzger 2002) expands the Environmental quotient. It follows the same approach, but in addition of the Potential environmental impact (PEI) of waste, that associated to reactants is also included.
Atmospheric acidification	$= \sum PF_i \times \frac{\text{Mass substance}_i}{\text{Value added}}$	kg eq. SO <sub>2</sub> /€	Each one of these indicators by IChemE (2002) focuses on a particular environmental problem. The amount of the substance (i) emitted is multiplied by its potency factor (PF), which expresses the specific contribution of substance (i) to the environmental problem in question, per kg emitted. Potency factors are expressed in kg of a reference substance. All indicators are expressed in environmental burden per unit value added. Similar indicators have been developed by the Center for Waste Reduction Technologies (CWRT 2002) and the European Environment Agency (EEA 1999).
Global warming	$= \sum PF_i \times \frac{\text{Mass substance}_i}{\text{Value added}}$	kg eq. CO <sub>2</sub> /€	
Human health (carcinogenic) effects	$= \sum PF_i \times \frac{\text{Mass substance}_i}{\text{Value added}}$	kg eq. benzene/€	
Ozone depletion	$= \sum PF_i \times \frac{\text{Mass substance}_i}{\text{Value added}}$	kg eq. CFC-11/€	
Photochemical ozone	$= \sum PF_i \times \frac{\text{Mass substance}_i}{\text{Value added}}$	kg eq. ethylene/€	
Aquatic acidification	$= \sum PF_i \times \frac{\text{Mass substance}_i}{\text{Value added}}$	kg eq. protons/€	
Aquatic oxygen demand	$= \sum PF_i \times \frac{\text{Mass substance}_i}{\text{Value added}}$	kg eq. oxygen/€	
Ecotoxicity to aquatic life by metals	$= \sum PF_i \times \frac{\text{Mass substance}_i}{\text{Value added}}$	kg eq. copper/€	
Ecotoxicity to aquatic life by non-metals	$= \sum PF_i \times \frac{\text{Mass substance}_i}{\text{Value added}}$	kg eq. formaldehyde/€	

EU: Environmental Unfriendliness. PEI: Potential Environmental Impact. PF: Potency factor. (All these terms can be considered as synonymous).

### 2.3.2. Site-oriented methods

Site-oriented methods are considered here as those tools generally used to evaluate the environmental consequences of human activities at a specific geographic location. Three such approaches are briefly introduced: Environmental Auditing, Environmental Impact Assessment and Risk Assessment.

### 2.3.2.1. Environmental Auditing

The origin of Environmental Auditing lies in physical inspections of sites to check legal compliance and to identify major risks and liabilities (De Smet 1996). With the appearance of environmental management systems standards such as ISO 14001 (ISO 1996) and the EU's Eco-Management and Audit Scheme (EU 1993), the term environmental auditing is being also used referring to a check on the conformity of an environmental management system with the requirements of such a standard. According to ISO 14010 (ISO 1995), Environmental Auditing is *"a process of systematic testing and objective assessment of evidence to determine whether environmental activities, events, conditions and systems, or information about these, conform to audit criteria and communication of results to customers"*.

Environmental Auditing involve the use of an independent party to carry out the audit, and the concept of checking against given requirements, either legislative, laid down in policy, or set out in a standard. EA may require the collection of data on inputs to and outputs from the activity being audited. However, the focus of EA is on the activity being audited and not on the upstream and downstream activities, nor necessarily on actual or potential impacts on the environment.

### 2.3.2.2. Environmental Impact Assessment

Environmental Impact Assessment (EIA) is used to investigate changes provoked in the environment at a specific site, for example those caused by construction projects, such as power plants, highways, etc. (Masera and Colombo 1992; Wathern 1988). EIA is thus mainly a planning tool of prospective nature, concerned with the management of land. It considers the environmental effects during the construction and operation period of the activity under study. EIA can be considered as a procedural tool rather than as an analytical tool (De Smet et al. 1996), developed in a legislative context (EU 1985).

EIA starts with the elaboration of an environmental impact study, including both qualitative and quantitative information aimed at foreseeing, identifying, determining and correcting the environmental consequences that the activity may have on the quality of human life and the environment. This study is the basis for the environmental authorities to submit an environmental impact declaration, accepting or refusing the project.

### 2.3.2.3. Risk Assessment

The term Risk Assessment is used for a wide variety of methods concerned with assessing the adverse effects of an activity on human safety and ecosystems. Two main types of risk assessment can be distinguished: Accident Risk Assessment (ARA) and Environmental Risk Assessment (ERA).

ARA (Roorda and Van der Ben 2002) is used in situations where events with low probability of occurrence are associated with major consequences, such as failures in chemical or nuclear plants. The analysis always focuses on the risk posed to the surrounding area and is therefore always site-specific. Typical methods used in accident risk analysis are fail trees and event trees (AIChE 1985).

ERA is concerned with the effects of routine industrial operations, excluding failures. ERA is defined by Sonneman and coworkers (2004) as *"a process for determining the probability for negative effects on human health or the environment as a result of exposure to one or more physical, chemical or biological agents"*. The ERA methodology consists on four steps: hazard identification, exposure assessment, dose-response assessment and risk characterization. This form of Risk Assessment can be used in site-specific as well as non-site-specific studies (Roorda and Van der Ben 2002). Site-specific ERA is often used to assess whether concentrations around a particular facility are below statutory limits, while

non-site-specific ERA is generally concerned with the risks posed by a particular substance or group of substances in a geographical region or country. This form of ERA can be used by the authorities to approve or reject new chemicals.

### 2.3.3. Chain-oriented methods

As chain-oriented methods we refer to those addressing the entire life cycle of a process, product or service, that is, the chain starting with extraction of resources, manufacturing, etc., and finishing with disposal of waste at end of life. LCA is the most widely applied tool in this context, but it is not the only one. Along with LCA, Material Intensity per Service Unit, Sustainable Process Index, Exergy Analysis and Substance flow analysis are described.

#### 2.3.3.1. Material intensity per Service unit

The Material Intensity Per Service unit (MIPS) developed by Schmidt-Bleek (1993) aims at measuring the masses of natural resources moved over the entire life cycle of a product or a service. MIPS identifies 5 types of material categories: abiotic raw materials, biotic raw materials, earth movements in agriculture and silviculture, water, and air. These inputs are aggregated over the entire life cycle. The total mass for each category can be displayed separately, or summed up to obtain the Total Material Requirement (TMR) of the service in question.

The methodology to calculate MIPS (Ritthoff et al. 2002) can be compared to that of a simplified LCA, since several elements such as system boundaries, flow diagram, service unit (functional unit), among others, have to be defined. Next a compilation of inputs consumed during the life cycle (inventory analysis) is carried out, including materials, electricity, fuels, etc. Each one of these inputs (for example 1 kWh electricity or 1 kg steel) is then associated to its Material Intensity (MIT), that expresses the amount of the 5 types of raw materials needed to produce it (Wuppertal Institute 2005), also called its ecological rucksack.

MIPS can be used to compare resource intensity of chemical processes and products over their life cycle in a simple way. However, several limitations can be identified: first, it implicitly assumes that each mass input is equally undesirable, be it a fossil fuel or cooling water (Hertwich et al. 1997). Second, it says nothing on pollution and waste. The latter, for example, should be dumped as it is, otherwise transport and treatment would increase material inputs (Krotscheck 1997). Another possible limitation is that MIT factors for specific raw materials used by the chemical industry can be missing from the database developed by the Wuppertal Institute. An example of application to the evaluation of chemical processes can be found in Hoffmann et al. (2001).

#### 2.3.3.2. Sustainable Process Index

The Sustainable Process Index (SPI) (Krotscheck and Narodowslawsky 1996; Narodowslawsky and Krotscheck 2000) is based on an operational definition of sustainability: a sustainable economy uses resources at or below the rate at which they are created, and it produces only waste streams that can be dissipated in the environment without accumulating or threatening the ecosystems. Resource consumption and dilution volumes needed by a process are transformed by the SPI to an area, being the surface of the Earth the ultimate constraint for human activity.

The area required for a process consists of the area required for raw materials and energy production, area for installations, the area used for the staff, and the area for dissipation of waste. The area for renewable raw materials production is calculated on their net growth rate. Raw materials based on fossil fuels are treated as renewable, by taking into account their low rate of regeneration. For other non-renewable materials such as minerals, only energy demand for

extraction is considered. The area needed for energy supply is calculated under sustainable conditions, that is, from the average yield of renewable energy sources like photovoltaics or biomass. The dilution area for waste dissipation is based on reaction and sedimentation rates, rainfall, and environmental quality standards. When the total area associated to the process is obtained, it can be compared to the per capita area of a region, leading to a quantification of how many person's life support capacity is required by the process. Some examples of application in energy systems can be found in Krotscheck et al. (2000) and Narodowski and Krotscheck (2004).

The basic concept of SPI is simple and easy to understand. Furthermore, it is based on a life cycle approach evaluating inputs and outputs, making it more complete than the MIPS method. Nevertheless, it has been subject to several criticisms (Hertwich et al. 1997), mainly related to how area for non-renewable materials and for dilution of pollutants are calculated.

#### 2.3.3.3. Exergy-based Sustainability

Exergy may be regarded as a measure of available energy. In contrast to energy, exergy is consumed in all real world processes as entropy is produced (Szargut 1980). Due to the fact that it can be measured for any material (fuels, minerals, etc.), exergy is a natural choice for a common measure of resource quantity than either mass or energy (Ayres et al. 1998). Several uses have been suggested in the literature for exergy in environmental management: as a measure of thermodynamic efficiency in conventional process balances (Hinderink and van der Kooi 1999; Masini et al. 2001), in calculation of life cycle impact (Finnveden and Östlund 1997; Dewulf and Langenhove 2004) and as the key parameter in measuring sustainability of processes (Dewulf et al. 2000; Dewulf et al. 2001).

The exergy-based sustainability parameter developed by Dewulf and coworkers (2000) can be defined as a mean of the renewability and efficiency parameters for a given process. Renewability is defined as a ratio of renewable exergy consumption to total exergy consumption during the process life cycle. The efficiency parameter is calculated from the contributions of exergy used for various purposes: manufacturing, emission abatement, product abatement at the end of life, exergy content of the product and losses due to irreversible processes. This sustainability parameter varies between 0 and 1. A sustainable process would achieve a value of 1 in the calculations, meaning that only renewable exergy sources are used, zero emissions are produced, product abatement is not required and losses due to irreversibilities are not produced (Lapkin 2002).

Exergy and related terms, such as waste potential entropy, are strongly criticized by Krotscheck (1997), stating that it does not reflect common sense. On the other hand, the sustainability parameter has been successfully applied to several processes, although Lapkin (2002) states that using energy instead of exergy in this parameter would perform just as good. In a similar way to MIPS, the sustainability parameter does not include explicitly pollutant- and toxicity-related issues, although takes them into account indirectly by the exergy needed to abate these emissions until they are no longer harmful.

#### 2.3.3.4. Substance Flow Analysis

The objective of Substance Flow Analysis (SFA) is to make an input-output analysis of a particular substance through the material economy (Huppes 1993). It uses a systems approach in studying the substance along its chain of extraction, production, transformation, consumption, recycling and disposal as waste or emissions to air and water. SFA is one of a number of analytical approaches based on Material Flow Accounting (MFA), where "materials" are defined in a broader way than substances, ranging from timber and fuels to agricultural products (Peele 2005). SFA can be carried out on different levels, from the international scale (Van der Voet et al. 1996) to the site or activity level (Mersiowsky 2002).

SFA follows the substances with the aim of identifying those activities where action can be taken. It is not considered to be a holistic approach, due to the fact that the analysis is restricted to a single substance (De Smet et al. 1996). Its use could be misleading if it involves changes in the system that result in different environmental impacts due to increased use of other substances.

#### 2.3.3.5. Life Cycle Assessment

LCA is an environmental management tool which identifies all resources used and wastes generated to all environmental compartments (air, water and soil) over the whole life cycle of a specific good or service (De Smet et al. 1996). It is the only standardized tool currently used to assess products and processes (Sonneman et al. 2004). The LCA methodology consists basically of four steps: goal and scope definition, inventory analysis, impact assessment and interpretation.

The goal and scope must clearly state the intended objectives of application, and define the system under study: its function, boundaries, hypotheses, data requirements, etc. Then the inventory analysis consists of a material and energy balance of the product system, aiming at the identification and quantification of substances that may be environmentally relevant. The environmental significance of these substances is assessed in the impact assessment phase, and finally the interpretation phase consists of discussing the results of the study in the light of the goals initially set.

The main strength of LCA, according to De Smet et al. (1996) is its comprehensive character, that helps to avoid problem shifting, where a solution to a particular environmental problem causes a deterioration in another part of the life cycle or another environmental compartment. One of the main weaknesses of LCA derive from its holistic nature: because of the lack of temporal and spatial detail in the inventory data, actual impacts can not at present be assessed, but only so-called "potential impacts". See chapter 4 for more details on LCA.

#### 2.3.4. Suitability of reviewed tools in the Green Chemistry framework

Table 2.4 shows the main features of all the tools for environmental management reviewed. The final row summarizes whether or not these tools are considered to be useful for measuring "greenness" and for what purpose their use is suggested. As can be seen, only the tools focusing on procedure rather than on analysis, namely Environmental Impact Assessment and Environmental Auditing, are found to be of very limited use, while the remaining tools can play an useful role in Green Chemistry.

Indicators focusing on resource intensity, as well as those focusing on environmental impact of chemical reactions (environmental quotient and EATOS) can serve as a screening tool for chemists, at the first stage of development of synthetic products. Due to the fact that all these indicators are partial, a group of them must be selected in order to cover a wide enough range of environmental issues, as has been suggested by many authors (Jiménez-González et al. 2002; Curzons et al. 2001; Constable et al. 2001).

Indicators focusing on environmental impact such as those defined by IChemE are considered to be mainly addressed to environmental reporting and monitoring at the company level, although it seems also possible to apply them at the process and product level. In such a case, normalization in physical units (environmental burden per kg product, for example) would be preferable to value added, particularly if the indicator is to be used at the bench scale.

Risk Assessment can be a very useful tool when the focus of the analysis is on safety issues of a chemical plant, or on toxicological effects, either on humans or on the ecosystems, from chemicals or chemical processes. However, in order to assess local and regional effects, this tool requires the specific geographic location of the activity under assessment to be defined. As a consequence of the high level of detail on local issues, Risk Assessment is not able to account for life cycle impacts, although integration of this tool with LCA has been proved to be possible in industrial process chains (Sonneman et al. 2004). While ARA is an engineering tool for application at the facility level, ERA can be applied for chemicals once toxicological data is available, through the use of multimedia fate and exposure models.

Finally, chain-oriented tools are very useful when a global environmental assessment of chemical processes or products has to be made with a single tool. In contrast to Risk Assessment, life cycle tools can not give detailed information on local issues, but on the other hand they are able to give a picture of the entire life cycle. MIPS is considered the least recommendable method, as it is not able to take into account potential impacts from outputs (emissions and waste). This problem is partially solved by the exergetic sustainability indicator, as it includes the exergy needed to abate certain emissions. Only Substance Flow Analysis, Sustainable Process Index and LCA deal clearly with inputs and outputs generated "from cradle to grave", although their methodologies are very different. Substance Flow analysis is the most limited of these three tools as it focuses on a single substance. The application of life cycle tools implies collecting information not only on the physical product or on a chemical reaction, but also on upstream and downstream processes, something that can hinder the application of these tools at early stages of product or process development, due to the unavailability of some data.

Concluding, We see that different tools are used to answer different questions, having all tools their advantages and drawbacks. The choice of tool or group of complementary tools will depend from case to case on several factors, a list of which has been summarized in box 2.1.

Box 2.1. Factors affecting the choice of tools in Green Chemistry.

- **Object under assessment**  
Chemical product, chemical technology or process, chemical plant or chemical company.
- **Level of effort**  
Preliminary screening, detailed evaluation, monitoring, number of tools to be used.
- **Site dependency**  
Need to account for global, regional or local impacts.
- **Environmental issue of interest**  
Toxicity to humans and/or ecosystems, energy, waste management or environmental impacts in general.
- **Data availability**  
From laboratory, pilot plant or full scale.

Table 2.4. Summary of tools for environmental management and their potential use in Green Chemistry.

Aspect	Indicators (section 2.3.1)				Site oriented methods (section 2.3.2)			Chain-oriented methods (section 2.3.3)				
	Resource intensity	Environmental impact			Environmental Auditing	Environmental Impact Assessment	Risk Assessment	Material Intensity per Service unit	Exergy-based Sustainability	Sustainable Process Index	Substance Flow Analysis	Life Cycle Assessment
	Environmental quotient	EATOS	IChemE indicators									
Objective	Measure pressure on resources	Measure relative hazard from waste	Measure relative hazard from materials and waste	Measure impact from pollutants	Verify compliance with common standards	Assess positive and negative impacts of a project	Evaluate adverse effects from a hazardous activity	Measure pressure on resources	Measure sustainability of processes and products	Measure sustainability of processes and products	Accounting of flows through the economy	Measure life cycle impacts
Object analysed	Chemical reaction	Chemical reaction	Chemical reaction	Company, process or product	Company or site operations	planned project or facility	Specific hazardous activity	Life cycle of product or service	Life cycle of product or service	Life cycle of product or service	Specific substance	Life cycle of product or service
Spatial focus	Not site-specific	Not site-specific	Not site-specific	Not site-specific	Operational unit	Defined site	Defined site	Not site-specific	Not site-specific	Not site-specific	Not site-specific	Not site-specific
Time perspective	Retrospective and prospective	Retrospective and prospective	Retrospective and prospective	Retrospective and prospective	Retrospective	Prospective	Prospective	Retrospective and prospective	Retrospective and prospective	Retrospective and prospective	Retrospective	Retrospective and prospective
Input or output focus	Input	Output	Input and output	Output	Input and output	Input and output	Output	Input	Input and output	Input and output	Input and output	Input and output
Procedural or analytical focus	Analytical	Analytical	Analytical	Analytical	Procedural	Procedural	Analytical	Analytical	Analytical	Analytical	Analytical	Analytical
Effects considered	Not effect-oriented	Relative hazard associated to waste	Relative hazard associated to materials and waste	Potential impacts	Those for which requirements are given in a standard	All effects on the local environment	Toxicological	Not effect-oriented	Not effect-oriented	Not effect-oriented	Not effect-oriented	Potential impacts
Strengths	Ease of calculation	Ease of calculation, include effects in a simple way	Ease of calculation, include effects in a simple way	Ease of calculation, include potential impacts	Independent checking	Considers local impacts, both positive and negative	Assesses local and regional effects on specific targets	Includes the entire life cycle	Includes the entire life cycle, measures sustainability	Includes the entire life cycle, measures sustainability	Includes the entire life cycle	Considers global and regional impacts on a life-cycle basis
Weaknesses	Only inputs to the chemical reaction are considered. No information on impacts	No information on inputs, nor on other aspects outside of the chemical reaction	No information on aspects outside of the chemical reaction. Excludes energy	No information on aspects outside the chemical facility	Not necessarily focusing on impacts	Regional global impacts not included	Does not address life cycle impacts	Includes only information on inputs, Lack of temporal and spatial detail	Outputs only partially modeled, Lack of temporal and spatial detail	No information on effects, local or global, Lack of temporal and spatial detail	Potential misleading results from considering only one substance	Lack of temporal and spatial detail
Potential use in Green Chemistry	Day-to day screening of chemical reactions	Day-to day screening of chemical reactions	Day-to day screening of chemical reactions	Environmental reporting in companies	Limited utility	Limited utility	Assessment of toxicological effects from chemical products and processes	Screening of products and processes	Evaluation of products and processes	Evaluation of products and processes	Evaluation of particular substances	Evaluation of products and processes



## References to Chapter 2

- AIChE. 1985. *Guidelines for hazard evaluation procedures*. Prepared by Batelle Columbus Division for the Center for Chemical Process Safety.
- Anastas P T, Breen J J. 1997. *Design for the environment and Green Chemistry: the heart and soul of Industrial Ecology*. *Journal of Cleaner Production*, 5, 1-2, pp. 97-102.
- Anastas P, Warner J. 1998. *Green Chemistry Theory and Practice*. Oxford University Press. Oxford.
- Anastas P T, Williamson T C. 1998. *Green Chemistry: Frontiers in Benign Chemical Syntheses and Processes*. Oxford University Press, New York.
- Anastas P T, Heine L G, Williamson T C. 2000a. *Green Chemical Syntheses and Processes: Introduction*. In Anastas P T, Heine L G, Williamson T C. (Eds). 2000. *Green Chemical Syntheses and Processes*. American Chemical Society. Washington D.C.
- Anastas P T, Bartlett L B, Kirchoff M M, Williamson T C. 2000b. *The role of catalysis in the design, development, and implementation of green chemistry*. *Catalysis Today*, 55, pp.11–22.
- Anastas P T, Lankey R L. 2000. *Life cycle assessment and green chemistry: the ying and yang of industrial ecology*. *Green Chemistry*, 2000, 2, pp. 289-295.
- Anastas P T, Lankey R L. 2001. *Going green*. *Chemistry in Britain*, may 2001, pp. 26-29.
- Anastas P T, Kirchoff M M, Williamson T C. 2001. *Catalysis as a foundational pillar of green chemistry*. *Applied Catalysis A: General*, 221, pp. 3-13.
- Anastas P T, Kirchoff M M. 2002. *Origins, Current Status, and Future Challenges of Green Chemistry*. *Accounts of Chemical Research*, 35, 9, pp. 686-694.
- Anastas P T, Zimmerman J B. 2003. *Design through the 12 principles of Green Engineering*. *Environmental Science and Technology*, 37, 95A-101A.
- Astrup Jensen A. 2001. *Establishment of a European Green and Sustainable Chemistry Award*. European Environment Agency. Technical Report N° 53. Copenhagen, Denmark.
- Ayres R U, Ayres L W, Martínás K. 1998. *Energy, waste accounting and life-cycle analysis*. *Energy*, 23 (5), pp. 355-363.
- Bastoli C. 1998. In Praznik W, Huber A. (Eds.). *Carbohydrates as Organic Raw Material IV*. WUV, Vienna.
- Brennecke J F. 2004. *Green Engineering*. *Green Chemistry Journal*, 6 (8), p. 362.
- Campbell C J, Laherrere J H. 1998. *The End of Cheap Oil*. *Scientific American*. March 1998, p. 60.
- Clark J H. 1999. *Green Chemistry: challenges and opportunities*. *Green Chemistry* 1, 1, pp. 1-7.
- Clark J H, Dekamin M G, Moghaddam F M. 2002. *Genuinely catalytic Fries rearrangement using sulfated zirconia*. *Green Chemistry*, 2002, 4, pp. 366-368.
- Collins T J, Horwitz C P, Ryabov A D, Vuocolo L D, Gupta S S, Ghosh A, Fattaleh N L, Hangun Y, Steinhoff B, Noser C A, Beach E, Prasuhn D Jr, Stuthridge T, Wingate K G, Hall J, Wright J L, Suckling I, Allison R W. 2002. In Lankey R L, Anastas, P T. (Eds.). *Advancing Sustainability through Green Chemistry and Engineering*. American Chemical Society: Washington D.C. Chapter 4.
- Constable J C, Curzons A D, Cunningham V L. 2002. *Metrics to "green" chemistry – which are the best?*. *Green Chemistry*, 2002, 4, pp. 521-527.
- Constable J C, Curzons A D, Freitas dos Santos L M, Geen G R, Hannah R E, Hayler J D, Kitteringham J, McGuire M A, Richardson J E, Smith P, Webb R L, Yu M. 2001. *Green Chemistry measures for process research and development*. *Green Chemistry*, 2001, 3, pp. 79.
- Curzons A D, Constable D J C, Mortimer D N, Cunningham V L. 2001. *So you think your process is green, how do you know? – using principles of sustainability to determine what is green – a corporate perspective*. *Green Chemistry*, 2001, 3, pp. 1-6.

- CWRT. 2002. Collaborative Projects: Focus area Sustainable Development: Development of Baseline Metrics; 2002. <http://www.aiche.org/cwrt/pdf/BaselineMetrics.pdf>
- De Smet B, Hemming C, Posthwaite D, Markovic V, Baumann H, Cowell S, Pessa C, Sund L, Moilanen T, Som C, Plas C, Steen B, Engel L, Heiskanen E, Klos Z. 1996. *Life Cycle Assessment and conceptually related programmes*. Report of the SETAC-Europe Working Group. Brussels.
- Dewulf J, Van Langenhove H, Dirckx J. 2001. *Exergy analysis in the assessment of the sustainability of waste gas treatment systems*. The Science of the Total Environment, 273 (1-3), pp. 41-52.
- Dewulf J, Van Langenhove H, Mulder J, Van den Berg M M D, Van der Kooij H J, de Swaan Arons J. 2000. *Illustrations towards quantifying the sustainability of technology*. Green Chemistry, 2 (3), pp. 108-114.
- Dewulf J, Van Langenhove H. 2004. *Thermodynamic optimization of the life cycle of plastics by exergy analysis*. International Journal of Energy Research, 28 (11), pp. 969-976.
- Dewulf J, Van Langenhove H. 2005. *Integrating Industrial Ecology principles into a set of environmental sustainability indicators for technology assessment*. Resources, Conservation and Recycling, 43, pp. 419-432.
- Domènech X, Ayllón J A, Peral J, Rieradevall J. 2002. *How green is a chemical reaction? application of LCA to Green Chemistry*. Environmental Science and Technology, 36, 5517-5520.
- Domènech X. 2005. *Química Verde*. Rubes Editorial, Barcelona.
- Ehrenfeld J, Gertler N. 1997. *Industrial Ecology in Practice: The Evolution of Interdependence at Kalundborg*. Journal of Industrial Ecology, 1 (1) pp. 67-79.
- EEA. 1999. *A first set of eco-efficiency indicators for industry: pilot study*. Final Report. Anite Systems, Luxembourg.
- Eissen M, Metzger J O. 2002. *Environmental performance metrics for daily use in synthetic chemistry*. Chemistry – A European Journal, 8, 16, pp. 3580-3585.
- EU. 1985. *Council Directive 85/337/EEC of 27 June 1985 on the assessment of the effects of certain public and private projects on the environment*. Official Journal L 175, 05/07/1985 P. 0040 – 0048.
- EU. 1993. *Council Regulation 1836/93 of 29 June 1993 allowing voluntary participation by companies in the industrial sector in a Community eco-management and audit scheme*. Official Journal L 168, 10/7/1993.
- Finnveden G, Östlund P. 1997. *Exergies of natural resources in life-cycle assessment and other applications*. Energy, 22 (9), pp. 923-931.
- Füssler C, James P. 1999. *Eco-innovación: integrando el medio ambiente en la empresa del futuro*. Ed. Mundi-Prensa, Madrid.
- Gonzalez M A, Smith R L. 2003. *A methodology to evaluate process sustainability*. Environmental Progress, 22 (4), pp. 269-276.
- Graedel T. 1994. *Industrial Ecology – Definition and Implementation*. In Socolow R. et al. (Eds.). *Industrial Ecology and Global Change*. Cambridge University Press, New York, Chapter 3.
- Graedel T. 1999. *Green Chemistry in an industrial ecology context*. Green Chemistry, 1999, 1 (5), pp. G126-G128.
- Heinzle E, Weirich D, Brogli F, Hoffmann V H, Koller G, Verduyn M A, Hungerbühler K. 1998. *Ecological and economic objective functions for screening in integrated development of fine chemical processes. 1. Flexible and expandable framework using indices*. Industrial & Engineering Chemistry Research, 37, pp. 3395-3407.
- Hellweg S, Fischer U, Scheringer M, Hungerbühler K. 2004. *Environmental assessment of chemicals: methods and application to a case study of organic solvents*. Green Chemistry, 2004, 6, pp. 418-427.
- Hertwich E G, Pease W S, Koshland C P. 1997. *Evaluating the environmental impact of products and production processes: a comparison of six methods*. The Science of the Total Environment, 196, pp. 13-29.
- Hinderink P, van der Kooij H J, de Swaan Arons J. 1999. *On the efficiency and sustainability of the process industry*. Green Chemistry 1 (6), pp. G176-G180.
- Hoffmann V H, Hungerbühler K, Mc Rae G J. 2001. *Multiobjective screening and evaluation of chemical process technologies*. Industrial & Engineering Chemistry Research, 40, pp. 2513-4524.

- Hudlicky T, Frey D A, Koroniak L, Claeboe C D, Brammer L E. 1999. *Toward a "reagent-free" synthesis*. Green Chemistry, 1999, 1 (2), pp. 57-59.
- Huppes G. 1993. *Macro-environmental policy: principles and design*. Doctoral thesis. University of Leiden, Netherlands.
- IARC. 2005. IARC Monographs on the Evaluation of Carcinogenic Risks to Humans. [www-cie.iarc.fr/](http://www-cie.iarc.fr/)
- ICHEME. 2002. *The sustainability metrics. Sustainable development progress metrics*. Institution of Chemical Engineers. [www.icheme.org/sustainability/](http://www.icheme.org/sustainability/)
- ISO. 1995. *Guidelines for environmental auditing – General principles*. Geneva, Switzerland.
- ISO. 1996. *ISO 14001: Environmental management systems – Specification with guidance for use*. Geneva, Switzerland.
- Jackson T. 2001. *Industrial Ecology and Cleaner Production*. In Ayres R U, Ayres L W. (Eds.). *A Handbook of Industrial Ecology*. Edward Elgar Publishing Limited, Cornwall, U.K.
- Jiménez-González C, Constable D J C, Curzons A D, Cunningham V L. 2002. *Developing GSK's green technology guidance: methodology for case-scenario comparison of technologies*. Clean Technologies and Environmental Policy, 4 (1), pp. 44-53.
- Kirchhoff M. 2003. *Promoting Green Engineering through Green Chemistry*. Environmental Science and Technology, 37, 5349-5353.
- Koller G, Weirich D, Brogli F, Heinzle E, Hoffmann V H, Verduyn M A, Hungerbühler K. 1998. *Ecological and economic objective functions for screening in integrated development of fine chemical processes*. 2. Stream allocation and case studies. Industrial & Engineering Chemistry Research, 37, pp. 3408-3413.
- Krotscheck C, Narodoslawsky M. 1996. *The Sustainable Process Index. A new dimension in ecological evaluation*. Ecological Engineering, 6 (4), pp. 241-258.
- Krotscheck C. 1997. *Measuring eco-sustainability : comparison of mass and/or energy flow based highly aggregated indicators*. Envirometrics, 8, 661-681.
- Krotscheck C, König F, Obernberger I. 2000. *Ecological assessment of integrated bioenergy systems using the sustainable process index*. Biomass and Bioenergy, 18, pp. 341-368.
- Lancaster M. 2002a. *Green Chemistry An introductory Text*. RSC Paperbacks, UK.
- Lancaster M. 2002b. *Principles of Sustainable and Green Chemistry*. In Clark J, Macquarrie D. (Eds.). *Handbook of Green Chemistry & Technology*. Blackwell Science, Oxford, U.K.
- Lapkin A, Joyce L, Crittenden B. 2004. *Framework for evaluating the "greenness" of chemical processes: case studies for a novel VOC recovery technology*. Environmental Science and Technology. Vol. 38 pp. 5815-5823.
- Lapkin A. 2002. *Metrics of green chemical technology*. A report for Crystal Faraday Partnership. University of Bath, UK.
- Lewis H, Gertsakis J, Grant T, Morelli N, Sweatman A. 2001. *Design + Environment. A global guide to designing greener goods*. Greenleaf Publishing, Sheffield, U.K.
- Manzer L E, 1994. In Anastas P T, Farris C A. (Eds.). *Benign by Design: Alternative Synthetic Design for Pollution Prevention*. American Chemical Society, Washington, DC.
- Masera M, Colombo A G. 1992. *Contents and phases in an EIA study*. In Colombo A G. (Ed.). *Environmental Impact Assessment*. Kluwer Academic Publishers. Dordrecht, the Netherlands.
- Masini A, Ayres L W, Ayres R U. 2001. *An application of exergy accounting to five basic metal industries*. Centre for the Management of Environmental Resources. INSEAD, Fontainebleau, France. [www.insead.edu/CMER/publications/wp/Workingpaperandreports2001.htm](http://www.insead.edu/CMER/publications/wp/Workingpaperandreports2001.htm)
- McDonough W, Braungart M, Anastas P T, Zimmerman J B. 2003. *Applying the principles of Green Engineering to cradle-to-cradle design*. Environmental Science and Technology, 37 (23), pp. 435A-441A.
- Mersiowsky N. 2002. *Long-term fate of PVC products and their additives in landfills*. Progress in Polymer Science, 27 (10), pp. 2227-2277.

- Narodowski M, Krotscheck C. 2000. *Integrated ecological optimization of processes with the sustainable process index*. Waste Management, 20, pp. 599-603.
- Narodowski M, Krotscheck C. 2004. *What can we learn from ecological valuation of processes with the sustainable process index (SPI) – the case study of energy production systems*. Journal of Cleaner Production, 12 (2), pp. 111-115.
- Peele C. 2005. *Substance Flow Analysis and Material Flow Accounts*. Workshop background paper, "Framing a Future Chemicals Policy". Chemicals Policy Initiative of the Lowell Center for Sustainable production. Boston, april 28-29.
- Rigola M. 1998. *Producció + Neta*. Rubes Editorial, Barcelona.
- Ritthoff M, Rohn H, Liedtke C, Merten T. 2002. *Calculating MIPS. Resource productivity of products and services*. Wuppertal Institute for Climate, Environment and Energy at the Science Centre North Rhine-Westphalia. [www.wupperinst.org/Projekte/mipsonline/english.html](http://www.wupperinst.org/Projekte/mipsonline/english.html)
- Roorda A, Van der Ben B. 2002. *Appendix B: Areas of application of LCA*. In: Guinée J B, Gorree M, Heijungs R, Huppes G, Kleijn R, Udo de Haes H A, Van der Voet E, Wrisberg M N. *Life Cycle Assessment. An operational guide to ISO standards*. Volume 1, 2, 3. Centre of Environmental Science, Leiden University (CML), The Netherlands.
- Sagar A D, Frosch R A. 1997. *A perspective of Industrial Ecology and its application to a metals-industry ecosystem*. Journal of Cleaner Production, 5, pp. 39-45.
- Schmidt-Bleek F. 1993. *MIPS re-visited*. Fresenius Environmental Bulletin, 2, pp. 407-412.
- Sheldon R A. 1994. *Consider the environmental quotient*. Chemtech, March 1994, pp. 38-47.
- Sheldon R A. 1997. *Catalysis: The Key to Waste Minimization*. Journal of Chemical Technology and Biotechnology, 68 (4) pp. 381-388.
- Sikdar S K. 2003. *Sustainable development and sustainability metrics*. AIChE Journal, 49, 8, pp. 1928-1932.
- Sonneman G, Castells F, Schuhmacher M. 2004. *Integrated Life-Cycle and Risk Assessment for Industrial Processes*. Lewis Publishers, Florida, USA.
- SPOLD. 1995. *Synthesis report on the social value of LCA*. SPOLD Workshop, Brussels, June 20-21.
- Szargut J. 1980. *International progress in second law analysis*. Energy, 5 (8-9), pp. 709-718.
- Tischner U, Schminke E, Rubik F, Prössler M. 2000. *How to do Ecodesign?*. Verlag form, Frankfurt am Main, Germany.
- Trost B. 1991. *The Atom Economy – A Search for Synthetic Efficiency*. Science 254, 5037, pp. 1471-1477.
- UNEP-IE. 2004. [www.unepie.org/pc/cp/understanding\\_cp/related\\_concepts.htm](http://www.unepie.org/pc/cp/understanding_cp/related_concepts.htm)
- USEPA. 1996. *The Presidential Green Chemistry Challenge Awards, Summary of 1996 Award Entries and Recipients*. EPA 744-K-96-001.
- USEPA. 1998. *The Presidential Green Chemistry Challenge Awards, Summary of 1998 Award Entries and Recipients*. EPA 744-R-98-001.
- Van der Voet E, Kleijn R, de Haes H A U. 1996. *Nitrogen pollution in the European Union – origins and proposed solutions*. Environmental Conservation, 23 (2), pp. 120-132.
- Wathern P. 1988. *An introductory guide to EIA*. In Wathern P. (Ed.). *Environmental Impact Assessment. Theory and Practice*. Routledge, London, UK.
- Winterton N. 2001. *Twelve more Green Chemistry principles*. Green Chemistry 2001, 3 (6), pp. G73-G75.
- World Business Council for Sustainable Development (WBCSD). 1993. *Eco-efficiency*. World Business Council for Sustainable Development, Congress in Antwerp, Belgium.
- World Business Council for Sustainable Development (WBCSD). 2005. [www.wbcscd.org/templates/TemplateWBCSD1/layout.asp?type=p&MenuId=MzI4&doOpen=1&ClickMenu=LeftMenu](http://www.wbcscd.org/templates/TemplateWBCSD1/layout.asp?type=p&MenuId=MzI4&doOpen=1&ClickMenu=LeftMenu)
- Wuppertal Institute for Climate, Environment and Energy. 2005. *Table containing Material Intensity factors of materials and energy sources*. [www.wupperinst.org/Projekte/mipsonline/download/MIT\\_v2.pdf](http://www.wupperinst.org/Projekte/mipsonline/download/MIT_v2.pdf)

# CHAPTER 3.

## Advanced Oxidation Processes for Water and Wastewater Treatment

---

*“The trouble with water - and there is trouble with water- is that they're not making any more of it. They're not making any less, mind, but no more either. There is the same amount of water in the planet now as there was in prehistoric times. People, however, they're making more of - many more, far more than is ecologically sensible - and all those people are utterly dependent on water for their lives (humans consist mostly of water), for their livelihoods, their food, and increasingly, their industry. Humans can live for a month without food but will die in less than a week without water. Humans consume water, discard it, poison it, waste it, and restlessly change the hydrological cycles, indifferent to the consequences: too many people, too little water, water in the wrong places and in the wrong amounts”.*

*Marq de Villiers (2000). Water*

### CONTENTS

3.1. Introduction .....	37
3.1.1. The hydroxyl radical .....	38
3.1.2. Suitability of AOPs as water treatment technologies.....	38
3.2. Heterogeneous Photocatalysis .....	40
3.2.1. Process fundamentals.....	40
3.2.2. Titanium dioxide .....	40
3.2.3. Factors affecting heterogeneous photocatalysis .....	41
3.2.3.1. Dissolved oxygen .....	41
3.2.3.2. pH.....	41
3.2.3.3. Catalyst concentration.....	41
3.2.3.4. Pollutant concentration.....	42
3.2.3.5. Radiation intensity .....	42
3.2.3.6. Temperature.....	42
3.2.4. Advantages and drawbacks .....	42
3.2.5. Applications and state of the art .....	43
3.3. Ozonation.....	45
3.3.1. Process fundamentals.....	45
3.3.2. Enhancement of hydroxyl radical production.....	45
3.3.2.1. Ozone in combination with hydrogen peroxide.....	46
3.3.2.2. Ozone in combination with UV light.....	46
3.3.2.3. Ozone in combination with hydrogen peroxide and UV light .....	46
3.3.3. Advantages and drawbacks .....	46
3.3.4. Applications and state of the art .....	47

3.4. Homogeneous Photocatalysis: Fenton and photo-Fenton .....	49
3.4.1. Process fundamentals .....	49
3.4.1.1. Fenton process .....	49
3.4.1.2. Photo-Fenton process .....	49
3.4.2. Factors affecting Fenton and photo-Fenton .....	50
3.4.2.1. pH .....	50
3.4.2.2. Fe:H <sub>2</sub> O <sub>2</sub> ratio .....	50
3.4.2.3. Temperature .....	50
3.4.2.4. Inorganic anion concentration .....	50
3.4.3. Advantages and drawbacks .....	50
3.4.4. Applications and state of the art .....	51
3.5. AOPs as “Green” Chemical Processes .....	53
3.5.1. Compliance of AOPs and competing technologies with Green Chemistry principles .....	53
3.5.2. LCA as a tool for measuring “greenness” of AOPs .....	56
References to Chapter 3 .....	57

The aim of this chapter is, in first place, to present AOPs, a group of technologies increasingly used to decontaminate water. From this group, only those technologies assessed in following chapters are presented in detail, namely heterogeneous photocatalysis, ozonation, and Fenton and photo-Fenton processes, describing their fundamental mechanisms, advantages and drawbacks, as well as the state of the art. Subsequently, a discussion is made on the “greenness” of these AOPs when compared to other technologies for wastewater treatment, highlighting the need of a quantitative tool to accomplish this purpose. At this point, taking into account the tools reviewed in chapter 2 and attending to the type of assessment to be done, LCA is finally suggested as an appropriate tool.

### 3.1. Introduction

Water is the most essential element required for life to exist. It is a resource that not only provides basic needs for all organisms on the planet, but also is the key to economic development, generating wealth through agriculture, commercial fishing, power generation, industry, transport and tourism. Water is vital for all global ecosystems. However, the facts show that we face a global water crisis.

Like all natural resources, fresh water reserves are limited. In fact, less than 1% of the planet's water is available for human consumption. In the present century, more than 1.2 billion people worldwide have no access to safe drinking water supply, causing around 80% of all infectious diseases in the third world. In the EU, four countries, namely Cyprus, Italy, Malta and Spain are considered as water-stressed (EEA 2005), and 20% of all surface water in the Union is seriously threatened with pollution (EU 2002). In addition, water demand is also a potential source of violence and warfare, as more than 60% of the world's population live in countries that adjoin rivers which are permanently posing cause for conflicts (Bauer and Fallmann 1997). Given the numerous and increasing pressures on water resources, it is vital to apply legislative and technical instruments facing these problems effectively and helping to secure these resources for future generations.

Among other elements in water management, an efficient treatment of industrial wastewaters is required. New laws and regulations, such as the European Water Framework Directive (EU 2000) address many types of pollutants not amenable to conventional biological treatments, due to their toxicity, chemical stability or difficulty in being completely mineralised. The destruction of these pollutants must be therefore demanded to other non-biological technologies (Andreozzi et al. 1999). These technologies consist of conventional phase separation processes, and methods aiming at the destruction of the contaminants. Among the latter the so-called Advanced Oxidation Processes (AOPs) are found (Legrini et al. 1993; Gogate and Pandit 2004a; Gogate and Pandit 2004b; Pera-Titus et al. 2004; Parsons 2004), which are those methods based on the in situ production of transient radical species of great oxidant power, specially hydroxyl radicals ( $\text{OH}\cdot$ ). There are many methods (chemical, photochemical, sonochemical, radiolytic) by which  $\text{OH}\cdot$  radicals can be generated:

- Heterogeneous photocatalysis
- Ozonation processes
- Fenton and photo-Fenton processes
- Hydrogen peroxide/UV processes
- Photoelectrocatalysis processes
- Ultrasound processes
- UV/electron beam irradiation processes

In this chapter, only the first three methods are described in detail, as they are the ones to be environmentally assessed in chapters 5 and 6. Nevertheless, they are among the most widely studied AOPs (Pérez 2001; Blanco 2002). For an overview of the above list of processes, see Parsons (2004).

### 3.1.1. The hydroxyl radical

The oxidation potentials for common oxidants are listed in table 3.1. As can be seen, the most powerful oxidizing species after fluorine is the hydroxyl radical, a short-lived, extremely potent oxidant capable of attacking almost any organic molecule. Reactions in aqueous solution involving the presence of OH· radicals show rate constants in the order of  $10^6$ - $10^9$  M<sup>-1</sup> s<sup>-1</sup> (Farhataziz and Ross 1977; Hoigné and Bader 1983). Furthermore, the hydroxyl radical is characterised by a low selectivity of attack, which is a useful attribute for an oxidant used in wastewater treatment (Andreozzi et al. 1999).

Table 3.1. Oxidation potential of main oxidative species.

Substance	E° (V vs. NHE)
Fluorine	3.03
Hydroxyl radical	2.80
Atomic oxygen	2.42
Ozone	2.07
Hydrogen peroxide	1.78
Permanganate	1.68
Chlorine	1.36

Source: Legrini et al. 1993.

The main mechanism by which OH· radicals attack organic molecules is hydrogen abstraction (eq. 3.1). This reaction generates organic radicals which by addition of molecular oxygen yield peroxy radicals. These in turn initiate thermal oxidative degradation reactions, mineralising the substrate to carbon dioxide, water and inorganic ions. Yet other mechanisms of oxidative degradation are electron transfer to OH· radicals (eq. 3.2) and electrophilic addition to unsaturated bonds (eq. 3.3) (Legrini et al. 1993).



However, the role of this radical is still controversial in some AOPs. In the Fenton's reaction, for example, there are numerous studies attempting to provide evidence of its role, and the role of oxidants other than the OH· radical (Bossmann et al. 1998; Pignatello 1999).

### 3.1.2. Suitability of AOPs as water treatment technologies

A suitable application of AOPs to wastewater treatment must consider that they make use of large amounts of reactants as hydrogen peroxide or ozone, as well as considerable amounts of energy, altogether leading to high operation costs. Therefore their application seems only advisable when more economic options can not be used.

Biological treatment is nowadays considered the cheapest and most environmentally friendly process for wastewater treatment (Sarrià et al. 2002), but its applicability is dependent on the biodegradability of the substances present in the wastewater. According to Scott and Ollis (1995), biological treatment can be coupled with an AOP in two ways:



- On the one hand, wastewaters being toxic, inhibitory or refractory to microorganisms can be chemically pre-treated to obtain biodegradable intermediates, which will be further treated in the biological reactor (AOP as a pretreatment).
- On the other hand, if the compounds in wastewater are neither inhibitory nor toxic, then biological pretreatment can be used to remove the biodegradable fraction of wastewaters containing both refractory and biodegradable compounds, leaving the chemical oxidation step for the remaining refractory fraction (AOP as a polishing posttreatment).

In both of these cases, the combination of biological treatment and chemical oxidation takes advantage of the individual strengths of these technologies in order to achieve a given effluent quality, and at the same time minimising cost.

Concerning the pollution load of the wastewater to treat, AOPs are suggested as suitable processes by Andreozzi et al. (1999) only when small amounts COD content are present, namely below 5 g per litre (figure 3.1), since higher COD contents would require the consumption of too large amounts of expensive reactants, as stated above. When COD contents are substantially high, other techniques such as wet oxidation and incineration, can treat more conveniently the wastewaters.

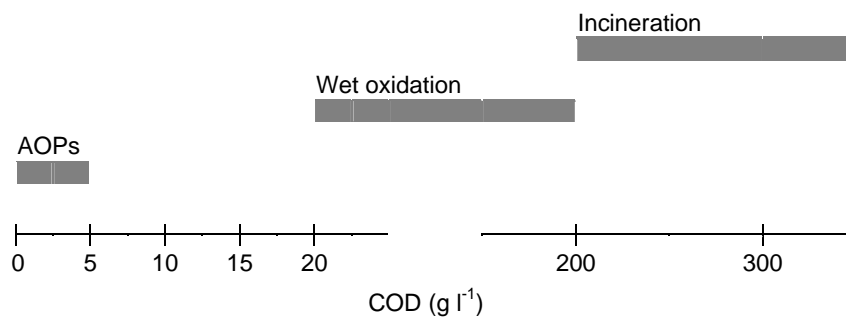

Figure 3.1. Suitability of chemical oxidation technologies for wastewater treatment according to COD contents. Source: Andreozzi et al. 1999.

## 3.2. Heterogeneous Photocatalysis

A fast growing field has emerged in the area of water and wastewater treatment, namely heterogeneous photocatalysis. Since the first paper on the issue 30 years ago (Carey et al. 1976), major reviews of the academic literature on this field have been reported (Konstantinou and Albanis 2003; Konstantinou and Albanis 2004; Herrman 2005; Devipriya and Yesodharan 2005).

### 3.2.1. Process fundamentals

Photocatalysis can be defined as the acceleration of a photoreaction by the presence of a semiconductor catalyst that can be activated by the adsorption of light of energy greater than its band-gap. The term “heterogeneous” refers to the fact that the contaminants are present in the aqueous phase, while the semiconductor is in the solid phase. The latter accelerates the chemical process because of the existence of electron-hole pairs (eq. 3.4). The photogenerated holes and electrons give rise to oxidation and reduction processes, respectively. In an aqueous solution, the water molecules adsorbed to the catalyst, are oxidized giving rise to OH· radicals. As the process is usually carried out in aerobic conditions, the species to be reduced is oxygen, generating the superoxide radical (Eq. 3.5 to 3.7). Organic pollutants adsorbed onto the surface of the catalyst are subsequently oxidized by OH· radicals.



Support of the OH· radical as the main reactive oxidant derives from the observation that intermediates detected during the photocatalytic degradation of halogenated aromatic compounds are typically hydroxylated structures, as those found when similar aromatics react with a known source of OH· radicals (Pérez 2001).

### 3.2.2. Titanium dioxide

Most of the studied semiconductors acting as photocatalysts are metal chalcogenides (CdS, ZnS, CdSe, ZnSe, CdTe) and metal oxides (TiO<sub>2</sub>, ZnO, SnO<sub>2</sub>, WO<sub>3</sub>) (Boye 2002). Titanium dioxide (TiO<sub>2</sub>) in particular has been demonstrated to be an excellent catalyst for photooxidation of a multitude of organic and inorganic compounds, and for this reason is the most intensively studied semiconductor (Herrmann 2005).

Titanium is the ninth most abundant element on the earth's crust. In its most stable form as an oxide, it can be found in three possible cristaline forms: brookite, rutile and anatase. From a photocatalytic point of view, only rutile and anatase are relevant, the latter having the highest photocatalytic activity (Fernández-Ibáñez et al. 2004).

TiO<sub>2</sub> is a semiconductor with a band gap energy of around 3.2 eV, as a consequence, the required wavelength to photoexcite an electron is 390 nm or shorter, which is near the limit of UV and visible light. Advantages of TiO<sub>2</sub> are its chemical inertness, photostability, high reaction rates and relatively low price. Among the different options available in the market, Degussa P-25® is one of the most efficient and tested. It is a powder with a particle size of around 25 nm,

forming aggregates of several hundred nanometers to several micrometers in aqueous solution, with a surface of 50 m<sup>2</sup>g<sup>-1</sup>, consisting of 70% anatase and 30% rutile.

In most of the research carried out on water treatment, TiO<sub>2</sub> is used as powder dispersion (Parsons 2004). The use of such slurries imply a subsequent separation step, by means of filtration, centrifugation, or coagulation/flocculation (Fernández-Ibáñez et al. 2003). This increases the complexity and cost of the process, but on the other hand, slurry reactor photocatalytic systems are very efficient when compared to supported catalyst reactors, due to the higher catalyst surface area obtained.

### 3.2.3. Factors affecting heterogeneous photocatalysis

The most important parameters affecting the performance of heterogeneous photocatalysis are dissolved oxygen, pH, catalyst concentration, initial substrate concentration, radiation intensity, and temperature (Blanco and Malato 2003). The next sections briefly describe the effect of each one of these variables on the process.

#### 3.2.3.1. Dissolved oxygen

The aim of the photocatalytic process is to mineralize an organic pollutant to carbon dioxide, water and mineral acids. As can be seen from the overall stoichiometry of the process (eq. 3.8), the presence of oxygen is essential.

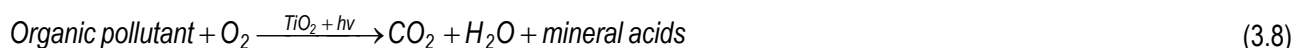

The concentration of dissolved oxygen affects the degradation rate. Consequently, a suitable liquid-gas contact must be assured. In an industrial plant using high flow rates or recirculation, the addition of oxygen is not necessary, as the water recovers the oxygen level when it reaches the tank, which can be stirred and open to the atmosphere.

#### 3.2.3.2. pH

The pH of the aqueous medium significantly affects TiO<sub>2</sub>, including the charge of the particle and the size of the aggregates. The pH at which the surface of an oxide is uncharged is called the point of zero charge (PZC), being of around 6 for TiO<sub>2</sub>, which is negatively or positively charged above and below this pH value, respectively. In addition, the mean size of TiO<sub>2</sub> particles and aggregates is also affected by pH. For pH values far enough from the PZC the particle size decreases, while aggregation increases near the PZC (Fernández-Ibáñez 2004). The particle size has an important influence on the photocatalytic process, due to changes in transmission, dispersion and absorption of light, and in the catalyst surface available.

#### 3.2.3.3. Catalyst concentration

The initial reaction rate in photoreactors is found to be directly proportional to catalyst mass. Nevertheless, when a certain concentration is reached, the reaction rate becomes independent of the catalyst mass. This limit depends on the characteristics of the photoreactor, and corresponds to the point where all TiO<sub>2</sub> particles are correctly illuminated. Above this point, turbidity avoids proper penetration of light in the reactor.

#### 3.2.3.4. Pollutant concentration

During the oxidation process, the surface of TiO<sub>2</sub> particles is progressively less covered with the pollutant, as the latter is decomposed. The reaction rate is thus expected to decrease with increasing illumination time. It is widely accepted that reaction rate of TiO<sub>2</sub>-based photocatalysis follows the Langmuir Hinshelwood kinetic model (Ollis et al. 1989).

#### 3.2.3.5. Radiation intensity

Photodegradation rate depends on radiation intensity, initially in a linear way. As intensity increases, reaction rate dependency goes down from one to a half order (Ollis 1991; Herrmann 1995), and if it keeps increasing, a point is reached where the rate no longer increases. This effect may be due to several causes, such as lack of electron scavengers (i.e. oxygen) provoking a high degree of e<sup>-</sup>/h<sup>+</sup> recombination, excessive number of photons producing too many e<sup>-</sup>/h<sup>+</sup> pairs that do not react and recombine, or due to saturation of the active centres of the catalyst surface with substrate and/or by-product molecules.

#### 3.2.3.6. Temperature

Photocatalytic systems do not require heating, as thermal energy does not produce additional catalyst activation. The true activation energy is zero, while the apparent activation energy is very low (a few kJ/mol) within the 20°-80°C range. However, at low (-40°-0°C) and high temperatures (>70°C) the photocatalytic activity decreases (Blanco and Malato 2003).

### 3.2.4. Advantages and drawbacks

The most important features which make heterogeneous photocatalysis attractive for treatment of polluted effluents can be summarized as follows (Malato 1999):

- The process takes place at room temperature and pressure,
- Oxygen required for the reaction is obtained from the atmosphere,
- The catalyst, TiO<sub>2</sub>, is cheap, innocuous, and can be reused,
- The catalyst can be attached to different types of inert matrices, and
- The source of photons could be the sun, a renewable and inexpensive energy source.

On the other hand, some drawbacks as pointed by Legrini and coworkers (1993) are the following:

- Slurry reactors require specific techniques for catalyst separation,
- Low quantum yield (ratio of reacting molecules to absorbed photons), and
- Slow degradation rates.

### 3.2.5. Applications and state of the art

Research on heterogeneous photocatalysis has focused mainly on the removal of organic pollutants from water. A wide range of substances have been shown to be completely mineralized using this method. Notable compounds are haloalkanes such as chloroform and tetrachloromethane, which are proved carcinogens often found in small amounts in drinking water treated by chlorination. Indeed, heterogeneous photocatalysis could find a practical application as a post-chlorination step in drinking water production. From the wastewater perspective, relevant substances that can be treated by photocatalysis are surfactants, dyes, hormones, herbicides and pesticides. In addition to the destruction of organic chemicals, also biological materials can be successfully treated, such as bacteria, viruses and moulds (Mills and Lee 2004).

Despite the intense level of academic research during the last 15 years, heterogeneous photocatalysis is just beginning with regard to commercial application. The low efficiency of the process, caused by the modest electric to UV light efficiency of UV lamps and the low quantum yield, makes the method unattractive for the major water-purification companies (Mills and Lee 2004). Among the companies promoting heterogeneous photocatalysis for water treatment, the canadian company Purifics®, which commercializes the Photo-Cat® system (Figure 3.2) is the most outstanding.



Figure 3.2. Photo-Cat® system. Source: [www.purifics.com](http://www.purifics.com)

The basic elements of the Photo-Cat® system are: prefilters to remove particles, a coalescor to remove emulsified oils and greases, the Photo-Cat® reactor where photodegradation takes place, and a membrane to separate the photocatalyst particles from the treated water and return the former to the inlet stream of the reactor and the latter to the effluent stream.  $\text{TiO}_2$  is in suspension, and the lamps used are of the germicidal type, surrounded by quartz tubes. Lamps and catalyst, along with the polluted water, are contained in stainless-steel tubes, connected together to form a series of racks. The company reports several case studies in the U.S. and Canada where this system has been used, namely to treat ground- and surface waters containing halogenated organics such as bis (2-chloroethyl) ether, dichloroethane and vinyl chloride, among others.

Although built for demonstration purposes, the solar detoxification plant installed at Hidrocen (Spain) deserves a special remark. This plant was developed within the SOLARDETOX project to treat selected non-biodegradable chlorinated solvents (NBCS), using 100 m<sup>2</sup> aperture area of compound parabolic collector (CPC) with a concentration ratio = 1, able to capture direct as well as diffuse UV sunlight. CPC collectors are chosen in solar detoxification applications due to the fact that they are simple, cost-effective, easy to use and require low capital investment (Blanco et al. 1999).

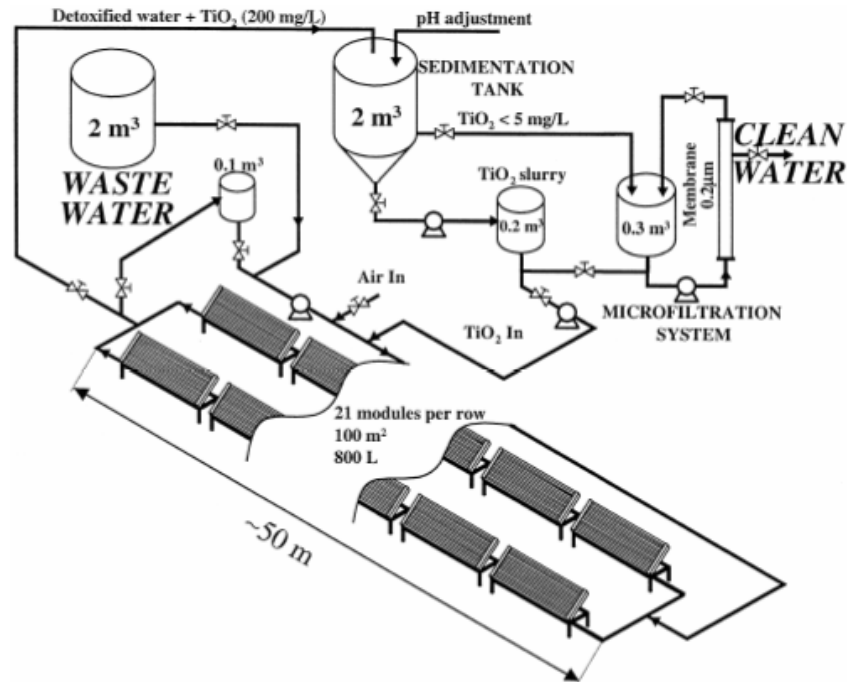

Figure 3.3. Schematic diagram of the Hidrocen solar detoxification plant. Source: Blanco et al. 1999.



Figure 3.4. Images of the photoreactor (left) and the  $\text{TiO}_2$  recovery system (right) of Hidrocen solar detoxification plant.

The plant (figure 3.3) works in batch mode, with  $\text{TiO}_2$  in suspension (200 mg/litre), being able to treat 2  $\text{m}^3$  wastewater in around 2 hours, and has been operative since the end of 1999. Operation can be described as follows: wastewater enters the photoreactor from a storage tank; when the system is full, a pump recirculates all through the collectors and a small tank. The concentrated  $\text{TiO}_2$  slurry and the air necessary for the reaction are injected in the circuit. Once the water is detoxified, the entire volume leaves to the sedimentation tank, where pH is adjusted to provoke fast sedimentation of the catalyst. The concentrated catalyst slurry is transferred from the bottom of the tank to a separate tank, while the supernatant is filtered by means of a microfiltration system to remove the remaining fraction of catalyst which has not settled (< 7 mg/litre). The concentrated slurry is recirculated through the microfiltration membrane and added to the  $\text{TiO}_2$  injection tank, in order to be reused. The clean water passed through the membrane is finally disposed of.

### 3.3. Ozonation

Ozone (O<sub>3</sub>) is an allotropic form of oxygen. It was discovered in 1783 by Van Marum, and named by Schonbein in 1840 (Haas 1999). Nevertheless, it has been during the last 20 years that its importance in water treatment has grown (Rice and Browing 1981).

#### 3.3.1. Process fundamentals

Ozone is produced by a high-voltage electric discharge in the presence of oxygen. It is a gas at normal temperature and pressure. As with oxygen, its solubility depends on temperature, partial pressure in the gas phase, and has recently been also thought to be a function of pH (Eckenfelder 1989). Ozone is unstable and its rate of decomposition increases with temperature and pH. The decomposition mechanism is initiated by OH<sup>-</sup> ions present in the aqueous medium. During the complex chain reactions involved, several radical species are formed, the OH· radical among them. A thorough research of the chain reaction mechanism of aqueous ozone has been carried out by Hoigné and coworkers (Hoigné 1985; Staehelin and Hoigné 1985; Hoigné 1988).

Ozone can react with the organic load present in the wastewater by two possible mechanisms: first by direct reaction with the ozone molecule, as displayed in equation 3.9. This reaction is slow and selective, involving substrates of high electronic density.



Second, by reaction with OH· radicals (eq. 3.11) produced by ozone decomposition, as shown in equation 3.10. Reaction 3.11 is 10<sup>6</sup>-10<sup>9</sup> times faster than reaction 3.9 (USEPA 1998), and the OH· radical is a more effective oxidant as compared to ozone (table 3.1), therefore, ozonation is more efficient when the conditions favour OH· production. According to Hoigné and coworkers, who calculated the OH· radical yield, 0.65 OH· molecules are produced for every ozone molecule decomposed.



Usually the degradation of pollutants involves both mechanisms, prevailing one or the other depending on the pH. In acidic conditions direct attack of ozone molecules is more important, while in alkaline conditions OH· radicals play a key role. However, too high pH conditions lead to a reduction in the process efficiency, due to bicarbonate and carbonate ions competing with the substrate for OH radicals (Domènech et al. 2001).

#### 3.3.2. Enhancement of hydroxyl radical production

Unless pH is increased, ozonation does not produce enough OH· radical concentration in order to completely mineralize dissolved pollutants. Compounds such as saturated alcohols, low-weight organochlorinated or carboxylic acids are refractory, since ozone degradation pathways are not effective, and not enough OH· radicals are generated. Three methods are usually described in the literature to overcome this problem: a non-photochemical method, based on

combining ozone with hydrogen peroxide, a photochemical method, consisting of simultaneous ozonation and irradiation with UV light, and finally the simultaneous combination of these three elements.

### 3.3.2.1. Ozone in combination with hydrogen peroxide

The action of ozone on organic compounds having a high molecular weight usually leads to small compounds which are refractory to ozone. For this reason it can be convenient to use an additional oxidant less selective than molecular ozone. Hydrogen peroxide has been suggested as a convenient agent for this purpose (Glaze et al. 1992). The basic mechanism by which hydrogen peroxide improves the process is by provoking the decomposition of ozone, thus producing OH· radicals, as shown by equation 3.12.



The simultaneous use of both oxidants allows to benefit from synergistic effects, leading to an additional destruction of organic matter. The process can be used to treat pollutants in very low concentrations (ppb), at pH values between 7 and 8. The optimum molar relation O<sub>3</sub>/H<sub>2</sub>O<sub>2</sub> is approximately 2:1 (Domènech et al. 2001).

### 3.3.2.2. Ozone in combination with UV light

Irradiation of ozone with UV light has also been observed to produce an increase in OH· radicals generation, allowing the process to achieve a faster and complete degradation of the pollutants (Blanco 2002). Ozone irradiation in water produces hydrogen peroxide, as shown in equation 3.13. Hydrogen peroxide in turn is photolized (eq. 3.14), generating OH· radicals, and reacting with excess ozone, which also produces OH· radicals (eq. 3.12). However the process is rather complex; for a detailed insight on the mechanisms, see Peyton and Glaze (1988).



Under these conditions, the system has the chemical behaviour of both O<sub>3</sub>/H<sub>2</sub>O<sub>2</sub> and H<sub>2</sub>O<sub>2</sub>/UV systems. Nevertheless, from a photochemical point of view, the absorption spectrum of ozone provides a much higher absorption cross section than hydrogen peroxide, and inner filter effects, as provoked for instance by aromatics, are less problematic (Andreozzi et al. 1999).

### 3.3.2.3. Ozone in combination with hydrogen peroxide and UV light

Yet another alternative for improving ozonation is the combination of both systems previously described: O<sub>3</sub>/UV and O<sub>3</sub>/H<sub>2</sub>O<sub>2</sub>, resulting in the O<sub>3</sub>/UV/H<sub>2</sub>O<sub>2</sub> system. In this case, also the OH· radicals are considered as the main oxidative species. Addition of hydrogen peroxide results in a net improvement of the process, due to the increase in production of OH· radicals, which are also photochemically generated thanks to UV irradiation (Blanco 2002).

## 3.3.3. Advantages and drawbacks

The main advantages of ozonation can be summarized as follows:

- The process is carried out at room temperature and pressure,



- In general, it leads to a quick and thorough pollutant removal (Pérez 2001),
- It is a well established and proven technology for water treatment (Haas 1999; Degrémont 1989),
- Ozone does not produce harmful byproducts, but only H<sub>2</sub>O and O<sub>2</sub> (Domènech et al. 2001).

While typically mentioned drawbacks are the following:

- Ozone production requires a large amount of electrical energy and oxygen, entailing high operation costs (Pérez 2001),
- High capital costs related to the equipment: ozoniser, abatement system for residual ozone, construction materials (stainless steel) to prevent corrosion, etc., (Andreozzi et al. 1999),
- Difficulties in achieving complete mineralization of pollutants, unless additional elements as hydrogen peroxide or UV light are considered,
- Poor solubility of ozone in water, leading to mass transfer limitations (Andreozzi et al. 1999; Pérez 2001; Domènech et al. 2001).

### 3.3.4. Applications and state of the art

As it has been mentioned in the last section, ozonation is a well established technology. In fact, the first electric discharge ozone generation device was constructed in 1857 by Siemens, with the first commercial application of this device taking place in 1893 (Water Pollution Control Federation 1984).

Ozone is widely used in drinking water stations, to improve taste, color, for oxidation of organic matter and dissolved metals, and for disinfection (Degrémont 1989). Indeed, ozone is used in these plants to kill bacteria and other biologic agents, avoiding the typical problems associated with other disinfectants based on chlorine or bromine, namely the generation of harmful byproducts like trihalomethanes. Yet another application of this technology in waters for human consumption is disinfection in swimming pools, as in the facilities of UAB (Servei d'Equipaments Esportius 2003).

Applications in industry are also highlighted. On the one hand, ozone is used in the paper industry as a bleaching agent for elemental chlorine free (ECF) and total chlorinated free (TCF) pulps, preventing the formation of AOX in wastewaters from the bleaching stage (EIPPCB 2000). On the other hand, applications for removal of pollutants from industrial wastewaters are also highlighted. Vandevivere et al. (1998) reports several case studies in which ozone is used in full-scale units to treat textile wastewaters containing dyes and surfactants. In this case ozone is usually employed as a polishing step after other unit processes, including biological treatment.

O<sub>3</sub>/UV and O<sub>3</sub>/UV/H<sub>2</sub>O<sub>2</sub> systems are reported by USEPA (1998) to be used at commercial scale to treat VOC-contaminated groundwater. A commercial scale Wedeco O<sub>3</sub>/UV system (figure 3.3) was used to treat groundwater containing trichloroethane (TCE) and perchloroethylene (PCE), at concentrations of 330 and 160 µg litre<sup>-1</sup>, respectively. The system was operated at a flow rate of 10 m<sup>3</sup> hour<sup>-1</sup>, an ozone dose of 5 mg litre<sup>-1</sup> and a UV-C light intensity of 30 mW litre<sup>-1</sup>, achieved 99 and 97% removal of TCE and PCE, respectively. The U.S. Filter O<sub>3</sub>/UV/H<sub>2</sub>O<sub>2</sub> system, formerly known as Ultrox system (figure 3.4), was demonstrated at a site in California to treat a groundwater polluted primarily with TCE, 1,1-dichloroethane (1,1-DCA), and 1,1,1-trichloroethane (1,1,1-TCA), at concentrations from 50-88 µg litre<sup>-1</sup>, 9.5-13 µg litre<sup>-1</sup>, 2.-4.5 µg litre<sup>-1</sup>, respectively. The system achieved removals as high as 99% for TCE, 65% for 1,1-DCA and 87% for 1,1,1-TCA.

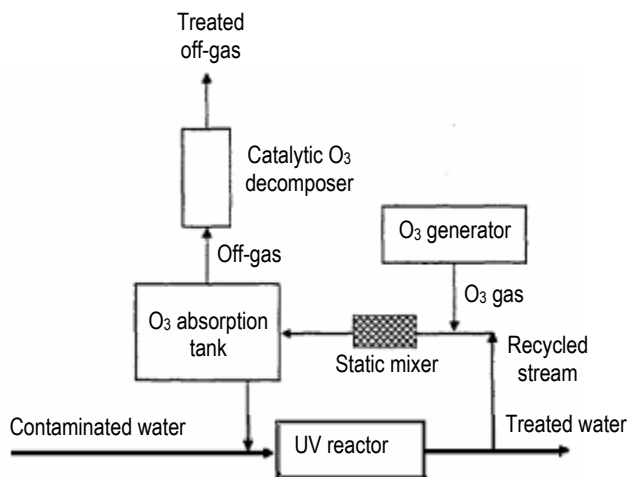

Figure 3.3. Flow configuration in a Wedeco O<sub>3</sub>/UV system for water contaminated with chlorinated VOCs. Source: USEPA 1998.

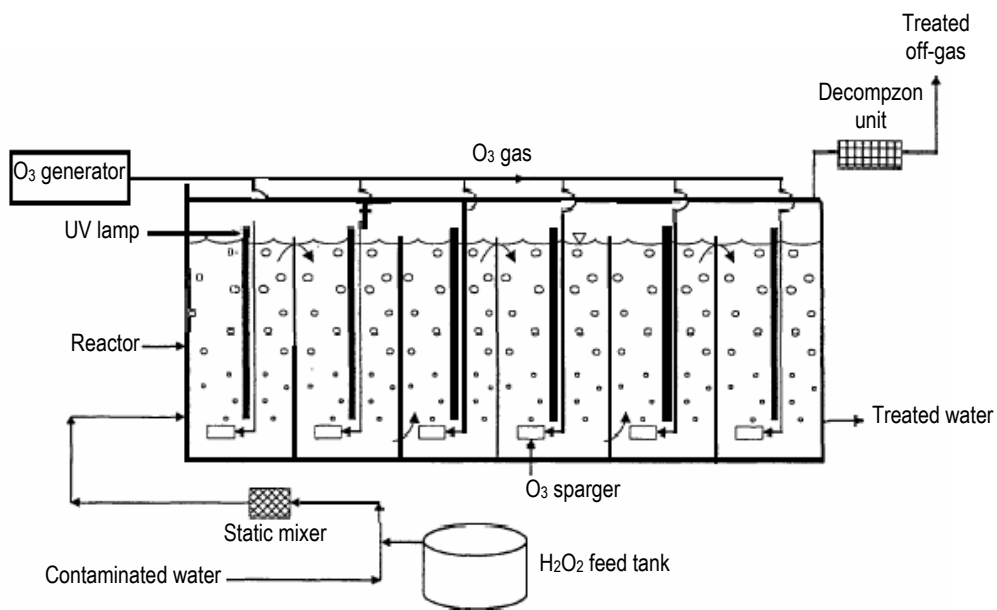

Figure 3.4. Flow configuration in a U.S. Filter O<sub>3</sub>/UV/H<sub>2</sub>O<sub>2</sub> system. Source: USEPA 1998.

## 3.4. Homogeneous Photocatalysis: Fenton and photo-Fenton

The Fenton reagent, a mixture of hydrogen peroxide and iron (II) salt, was discovered by Henry J.H. Fenton at the end of the XIX<sup>th</sup> century (Fenton 1894). In one or other of its various forms, this system is being increasingly used in the treatment of contaminated water and soil (Wadley and Waite 2004) and is considered as the most promising treatment among AOPs for remediation of highly contaminated waters (Bossman et al. 1998).

### 3.4.1. Process fundamentals

Two types of processes will be distinguished: the Fenton process, which takes place in dark conditions, and the photochemically enhanced Fenton process, usually referred to as photo-Fenton.

#### 3.4.1.1. Fenton process

Reaction between dissolved iron (II) and hydrogen peroxide in acidic aqueous solution leads to oxidation of iron (II) to iron (III) and is thought to form OH· radicals, as shown in equation 3.15. The reaction is spontaneous and takes place without the influence of light.



It was H.J.H. Fenton who first described the process, but it was actually Haber and Weiss (1934), who described the particular mechanism. However, the behaviour of this system cannot be completely explained on the basis of the sole reaction 3.15. In fact, as it has been pointed out in many recent studies (Pignatello 1992), if a proper pH is chosen (2.7-2.8), the reduction of iron (III) to iron (II) takes place, in the so-called Fenton-like reactions:



These reactions proceed at an appreciable rate, regenerating iron (II); the latter will in turn take part in reaction 3.15, giving rise to a real catalytic process (Andreozzi et al. 1999). Nevertheless, it must be highlighted that after more than a century of research into this system, there is still controversy on the exact intermediates that form, including whether or not the OH· radical itself forms (Dunford 2002; Kremer 1999).

#### 3.4.1.2. Photo-Fenton process

In the presence of UV-VIS light, the degradation rate of organic pollutants by Fenton processes has been observed to increase. In these conditions, the photolysis of iron (III) complexes allows regeneration of iron (II), which can further react with more hydrogen peroxide. In addition, this step produces new OH· radicals (eq. 3.18).



Photo-Fenton reactions can use low-energy photons, with wavelengths from 300 nm in the UV-A region (Andreozzi et al. 1999), up to 580 nm, in the visible region (Krutzler et al. 1999; Pignatello et al. 1999). Therefore, these reactions can be driven by solar energy, leading to a reduction in cost (Safarzadeh-Amiri et al. 1996; Bauer and Fallmann 1997). Another

advantage of photo-Fenton over dark Fenton is the fact that iron (II) concentrations can be orders of magnitude lower. On the other hand, hydrogen peroxide is continuously consumed, just as it is in dark Fenton (Domènech et al. 2001).

### 3.4.2. Factors affecting Fenton and photo-Fenton

Many constituents of the water as well as the conditions in which the process is carried out can substantially affect reaction rates and stoichiometry, due to effects in the solution chemistry. In this section the following parameters are discussed: pH, Fe:H<sub>2</sub>O<sub>2</sub> ratio, temperature, and inorganic anion concentration.

#### 3.4.2.1. pH

The performance of this reactive system is a function of pH. However, each group of reactions has its optimal performance at different pH values: on the one hand, Fenton reaction (eq. 3.15) is nearly pH independent (Pignatello 1992), while the Fenton-like reaction (eqs. 3.16, 3.17) is optimal at pH 2.8 (Pignatello 1992). On the other hand, the photo-Fenton reaction is clearly pH dependent (Pignatello et al. 1999); for high pH values, the rate decreases, due to the precipitation of Fe(OH)<sub>3</sub>, while for pH values below the optimal, the rate decreases due to the lower light absorption coefficient associated with the iron complexes formed.

#### 3.4.2.2. Fe:H<sub>2</sub>O<sub>2</sub> ratio

The reaction rate tends to increase with increasing hydrogen peroxide concentration (Wadley and Waite 2004). However, it seems that there is no agreement on the Fe:H<sub>2</sub>O<sub>2</sub> ratio leading to the best results, since different authors have reported different ratios (Pérez 2001). Anyway, large excesses of either iron or hydrogen peroxide could be detrimental, as they are also scavengers of OH· radicals.

#### 3.4.2.3. Temperature

In the case of photo-Fenton, for regeneration of iron (II) not only photochemical, but also parallel thermal reactions take place. Therefore, increasing the solution temperature leads to an increase in the observed reaction rates (Lee and Yoon 2004; Sagawe et al. 2001).

#### 3.4.2.4. Inorganic anion concentration

Degradation rates can be decreased due to the presence of certain anions that either scavenge OH· radicals or form unreactive species with iron. Some common species mentioned (Wadley and Waite 2004) are sulphate (SO<sub>4</sub><sup>2-</sup>), chloride (Cl<sup>-</sup>), nitrate (NO<sub>3</sub><sup>-</sup>), perchlorate (ClO<sub>4</sub><sup>-</sup>) and dihydrogen phosphate (H<sub>2</sub>PO<sub>4</sub><sup>-</sup>).

### 3.4.3. Advantages and drawbacks

Applying Fenton and photo-Fenton methods has the following advantages:

- The process is carried out at room temperature and pressure,
- Since reactions take place in homogeneous phase, there are no mass transfer limitations (Domènech et al. 2001),
- Iron is a highly abundant and non-toxic element (Wadley and Waite 2004),

- Hydrogen peroxide is easy to transport and handle. It is also environmentally benign in diluted form (Wadley and Waite 2004).
- Both chemicals are relatively inexpensive (Wadley and Waite 2004),
- The photo-Fenton process can use photons within a broader wavelength range as compared to heterogeneous photocatalysis (Gernjak et al. 2004; Blanco 2002).
- The photo-Fenton process could be performed using solar photons, a renewable and inexpensive source of energy (Safarzadeh-Amiri et al. 1996; Bauer and Fallmann 1997), and
- A treatment plant applying the Fenton process tends to be less expensive to build and operate than most other AOPs (Wadley and Waite 2004).

On the other hand, the following disadvantages are usually mentioned:

- The process requires and strict pH control (Andreozzi et al. 1999),
- When the process is finished and neutralization is carried out, an iron sludge forms, requiring appropriate disposal (Andreozzi et al. 1999; Venkatadri and Peters 1993).
- Hydrogen peroxide is continuously consumed through the degradation process (Domènech et al. 2001), and
- The photo-Fenton process using artificial light involves an additional energy consumption to run the lamps.

#### 3.4.4. Applications and state of the art

The Fenton and photo-Fenton processes have been applied to treat a wide variety of pollutants. According to Domènech et al. (2001), the Fenton process has been successfully used to degrade aliphatic compounds, chlorinated aromatic compounds, PCBs, nitroaromatic compounds, azo dyes, chlorobenzene, pentachlorophenol, phenols, chlorinated phenols, octachlorinated-p-dioxin, and formaldehyde. It is a good oxidant for herbicides and other soil contaminants such as hexadecane or Dieldrin. It can also be used to remove solvents, color, and for COD reduction. On the other hand, the photo-Fenton process is used to treat industrial wastewaters, soils and landfill leachate. It has also been used to reduce the COD content of municipal wastewaters (Blanco 2002). It can conveniently treat compounds such as polychlorinated phenols, nitroaromatic compounds, herbicides (2,4-D and 2,4,5-T) and pesticides.

With regard to full-scale applications, Vandevivere and coworkers (1998) report the existence of several plants in South Africa using Fenton's reagent to treat wastewaters from the textile industry. Also photo-Fenton has been applied in a demonstration plant to treat textile wastewaters (Sattler et al. 2004). Full-scale installations of photo-Fenton exist in the USA for treatment of water contaminated with VOCs and semivolatiles. The Calgon Rayox<sup>®</sup> ENOX system is an example of a commercial scale photo-Fenton system that has been used to treat contaminated groundwater and industrial wastewater (USEPA 1998). Wadley and Waite (2004) have reviewed a variety of patented technologies based on Fenton reaction, which have been used in remediation of contaminated soil and groundwater, namely the Geo-Cleanse Process<sup>®</sup>, the CleanOX Process, the modified Fenton's process by ISOTECH<sup>SM</sup>, the BIOX<sup>®</sup> Process and the On-Contact Remediation Process<sup>®</sup>.

Nevertheless, a special remark has to be made to the first commercial wastewater treatment plant applying solar-driven photo-Fenton, which has been installed in Spain (Blanco et al. 2004; Malato et al. 2004, Albaida Recursos Naturales y Medio Ambiente 2004).

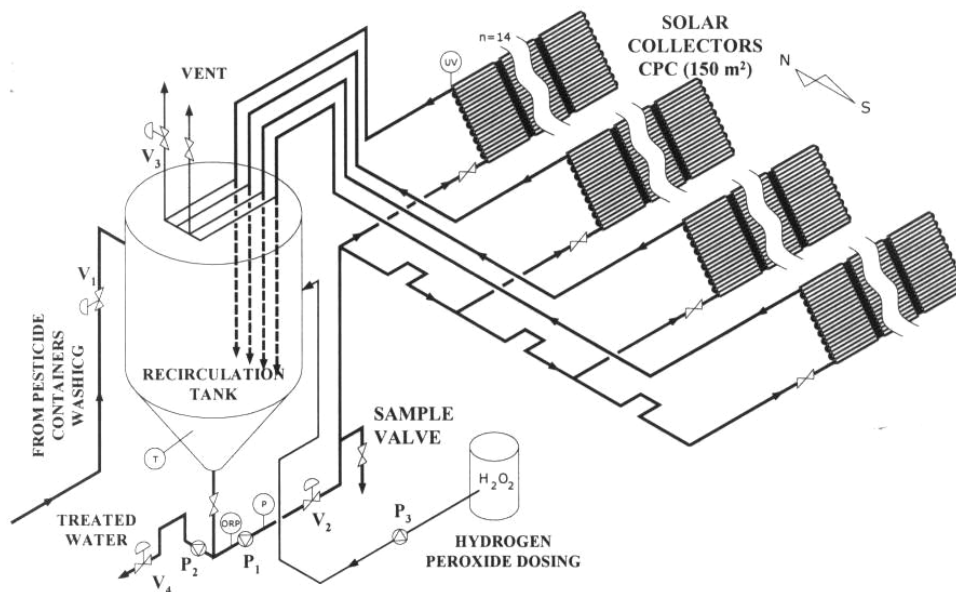

Figure 3.5. Schematic diagram of the Albaida plant in Almeria. Source: Malato et al. 2004.



Figure 3.6. Solar collector field of the Albaida plant in Almeria.

The plant was installed in 2004 in the facilities of Albaida Recursos Naturales y Medio Ambiente, S.A., in Almeria (southern Spain), where empty pesticide plastic bottles are recycled (shredded, washed and dried). Washing of shredded plastic generates a wastewater containing several hundred mg pesticide litre<sup>-1</sup>, which is treated by solar-driven photo-Fenton. The photoreactor consists of a solar CPC field with an aperture of 150 m<sup>2</sup> (figure 3.6) and a volume of 1,061 litres. The plant works in batch mode, and has been designed to treat 1,875 m<sup>3</sup> wastewater/year with an initial and final total organic carbon (TOC) of 100 and 20 mg/litre, respectively. The process starts with filtering to remove coarse particles, and storage. Next the wastewater enters a 1.6 m<sup>3</sup> tank (figure 3.5), where pH is adjusted to 3 and ferrous sulphate (1 mM Fe<sup>2+</sup>) as well as hydrogen peroxide are added. The water is pumped to the reactor and continuously recirculated; hydrogen peroxide is periodically added in order to maintain a proper concentration. When treatment is finished, a sample is taken to guarantee that effluent quality requirements are met. If so, the clean water is transferred to the bottle washing circuit, in order to reuse it. In this closed cycle, water may be reused up to 10 times before final discharge.

### 3.5. AOPs as “Green” Chemical Processes

AOPs in general or some techniques within this group have been suggested as “green” chemical processes (Domènech 2005), that is, as environmentally friendly processes for water and wastewater treatment. In this section this is discussed with regard to the 12 principles of Green Chemistry, and finally the suitability of LCA to support decisions on the “greenness” of these processes is examined.

#### 3.5.1. Compliance of AOPs and competing technologies with Green Chemistry principles

Rather than inherently “green”, a process can be considered “greener” or environmentally preferable when it is compared to another. As a consequence, some reference processes to which the AOPs are compared, must be defined. Adsorption on activated carbon is perhaps the most frequent technology to which AOPs are compared in the literature (Malato et al. 2001, 2002; Link and Turchi 1991; Klausner et al. 1992; Nijdam et al. 1999; Hirvonen et al. 1998). In addition, according to Andreatti and coworkers (1999), wet oxidation can be considered to some extent as a competing technology to AOPs (section 3.1.2). On the other hand, biological treatment is considered as the “greenest” wastewater treatment technology (Sarrià et al. 2001); although this may be true, we have seen that refractory or toxic pollutants can not be dealt with by this technology, therefore biotreatment is a complementary rather than a competing technology to AOPs.

In table 3.2 heterogeneous photocatalysis, ozonation, Fenton and photo-Fenton, activated carbon adsorption, and wet oxidation are checked against the 12 principles of Green Chemistry, in order to find out to what extent they comply with the main guidelines set by this framework, and whether AOPs can be considered “greener”, using the 12 principles as the only criteria. A detailed description of these principles can be found in chapter 2 (section 2.1.2).

The first aspect to highlight from the checklist in table 3.2 is the difficulty in applying the 12 principles to processes outside synthetic chemistry. As can be seen, 4 principles could not be checked against any technology due to their strong synthesis-oriented character. Nevertheless, after checking 8 from 12 principles, it proves difficult to conclude whether or not AOPs are “greener” chemical processes as compared to other technologies: too many criteria, and too qualitative. As pointed in chapter 2 (section 2.2), we see that “greenness” can not be measured solely on the basis of the Green Chemistry principles; if one or more processes have to be chosen for their advantageous environmental performance, a quantitative tool is clearly needed.

Table 3.2. Compliance of the studied AOPs and competing technologies with Green Chemistry principles.

Green Chemistry principles	Heterogeneous photocatalysis <sup>1</sup>	Ozonation <sup>1</sup>	Fenton and photo-Fenton <sup>1</sup>	Activated carbon adsorption <sup>2</sup>	Wet oxidation <sup>3</sup>
1. Prevention	The chemical used, TiO <sub>2</sub> , finally ends up as solid waste, but in small quantities, as it can be reused several times.	Produces no solid waste at all. Residual ozone in the off-gas must be destroyed	Iron salts used in the process end up as solid waste.	The process produces waste in form of spent carbon, which has to be disposed of by means of incineration, landfilling, or regenerated.	Off-gases are produced which may require downstream treatment, such as scrubbing, biofiltration or incineration.
2. Atom economy	This principle deals clearly with synthetic processes, just the opposite of these technologies, which aim at destroying synthetic compounds. As a consequence, atom economy is not an useful principle to discuss "greenness" of these processes.				
3. Less hazardous chemical syntheses	Here applies the same than for atom economy.				
4. Designing safer chemicals	Here applies the same than for atom economy.				
5. Safer solvents and auxiliaries	With regard to solvents, the process is carried out in aqueous solution. The only chemical used, TiO <sub>2</sub> , is innocuous.	It is also carried out in aqueous solution.	It is also carried out in aqueous solution. Two chemicals are mainly used: an iron salt, usually ferrous sulfate which is innocuous, and hydrogen peroxide, which is environmentally benign in diluted form.	Carried out in aqueous solution. The only material used, activated carbon, is an inert material.	Carried out in aqueous solution. No solvents or auxiliary materials required.
6. Design for energy efficiency	Can be energy intensive due to the use of lamps. However the possibility exists of using solar energy as a source of photons.	Ozonation is known to be an energy intensive process.	The Fenton process takes place in the dark. With regard to p(oto-Fenton, it can also be energy intensive as heterogeneous photocatalysis due to the use of lamps, although it can use less energetic photons. However the possibility also exists of using solar energy.	Low energy requirements, mainly due to pumping.	Energy intensive due to the need to work in middle to high pressures. If the wastewater has a low organic content, fuel must also be added to achieve combustion.
7. Use of renewable feedstocks	The three AOPs use oxygen, a clean and renewable reagent, as a precursor for hydroxyl radical formation.			Activated carbon may be of organic origin, although in wastewater applications it is usually based on bituminous coal.	Uses oxygen, a clean and renewable reagent, as oxidant.
8. Reduce derivatives	This principle applies only for synthetic processes and therefore is not useful to assess these technologies, which as has been pointed above, aim at destroying compounds instead of creating them.				



Table 3.2. Cont.

Green Chemistry principles	Heterogeneous photocatalysis <sup>1</sup>	Ozonation <sup>1</sup>	Fenton and photo-Fenton <sup>1</sup>	Activated carbon adsorption <sup>2</sup>	Wet oxidation <sup>3</sup>
9. Catalysis	As its name reads, this is a heterogeneous catalytic process, using semiconductor TiO <sub>2</sub> .	Ozonation is not a catalytic process. Ozone is used as a reagent.	The Fenton reagent, as its name reads, is not based on catalysis. On the other hand, photo-Fenton is a catalytic process with regard to iron. However, hydrogen peroxide must be added stoichiometrically.	Activated carbon adsorption is not a catalytic process.	Wet oxidation is not a catalytic process.
10. Design for degradation	As other previous principles, number 10 is concerned with synthetic processes, and therefore does not apply to these processes.				
11. Real-time analysis for pollution prevention	Besides oxygen, the process does not use reagents.	On-line measurement of residual ozone concentration in the reactor off-gas would allow to avoid adding excess reagent. Nevertheless this is more related to plant design rather than to the process itself.	On-line measurement of hydrogen peroxide concentration in the reactor would allow to avoid adding excess reagent. Nevertheless this is more related to plant design rather than to the process itself.	No reagents are added, besides activated carbon in the filter.	A thorough monitoring of operation parameters is needed (pressure, temperature, oxygen) to ensure faultless working.
12. Inherently safer chemistry for accident prevention	The process does not use toxic chemicals, therefore is inherently safe.	The use of ozone inherently implies a risk of eventual releases of this toxic gas.	This process uses iron salts, which are innocuous, and hydrogen peroxide, which is not toxic in diluted form. Fenton and photo-Fenton can be considered as inherently safe.	The process is inherently safe with regard to the chemicals used, but the pollutants remain adsorbed onto the carbon unless the latter is thermally treated.	A process working at high temperature and/or pressure intrinsically involves a risk of explosion.

## Sources:

<sup>1</sup> Based on information presented in sections 3.2, 3.3, and 3.4.

<sup>2</sup> Based on Malato et al. (2001, 2002), Link and Turchi (1991), Klausner et al. (1992), Nijdam et al. (1999), Hirvonen et al. (1998).

<sup>3</sup> Based on EIPPCB (2003).

### 3.5.2. LCA as a tool for measuring “greenness” of AOPs

Assessing AOPs from an environmental point of view requires a tool or set of complementary tools to be chosen. Part of chapter 2 has been devoted to review commonly used methods for environmental assessment, and a list of factors affecting the choice of tool have been identified (box 2.1). Box 3.1 shows these factors or conditions in the particular case of choosing an appropriate tool to assess AOPs.

Box 3.1. Factors affecting the choice of tools for environmental assessment of AOPs.

- **Object under assessment**  
A group of chemical technologies, namely AOPs for wastewater treatment. Then the object under assessment is not a physical product but a service.
- **Level of effort**  
Both a preliminary screening and a detailed evaluation of AOPs are to be carried out, using a single tool for this purpose.
- **Site dependency**  
The object under study is a technology, not a particular activity in a particular geographic location. For this reason local impacts can not be addressed, but mainly global impacts.
- **Environmental issue of interest**  
Although AOPs are designed to deal with toxic and refractory pollutants, toxicity is not the only issue of concern. A general environmental assessment is to be carried out. As a consequence energy, waste and other issues are important as well.
- **Data availability**  
Although some AOPs, namely ozonation, are well documented at commercial scale, most of the information must be obtained from laboratory experiments and pilot plants, while data from full-scale plants are scarce.

Attending to the conditions presented in box 3.1, it seems that in order to assess AOPs from an environmental point of view, a chain-oriented tool would be more appropriate than a set of indicators or a site-oriented tool. From the chain-oriented tools reviewed in chapter 2, LCA is currently the only standardized tool to assess product environmental loads (Sonneman et al. 2004), and for this reason its suitability is suggested. Perhaps the main constraint to its application is the limited amount of data available. According to Hellweg and coworkers (2004) and Hoffmann and coworkers (2001), a complete LCA can only be performed at advanced stages of chemical product or process development. Nevertheless, Domènech and coworkers (2002) demonstrated that LCA can be applied to a chemical reaction, in a simplified – but quantitative – way. All these issues are further discussed in chapter 4.

## References to Chapter 3

- Albaida Recursos Naturales y Medio Ambiente. 2004. *Depuración de aguas residuales procedentes del lavado de envases de plaguicidas mediante fotocátalisis solar*. TecnoEnergía, 37, pp. 58-60.
- Andreozzi R, Caprio V, Insola A, Marotta R. 1999. *Advanced oxidation processes (AOP) for water purification and recovery*. Catalysis today, 53, pp. 51-59.
- Bauer R, Fallmann H. 1997. *The Photo-Fenton oxidation. A cheap and efficient wastewater treatment method*. Research on Chemical Intermediates, 23 (4), pp. 291-388.
- Blanco J, Malato S, Fernandez P, Vidal A, Morales A, Trincado P, Oliveira J C, Minero C, Musci M, Casalle C, Brunotte M, Tratzky S, Dischinger N, Funken K H, Sattler C, Vincent M, Collares-Pereira M, Mendes J F, Rangel C M. 1999. *Compound parabolic concentrator technology development to commercial solar detoxification applications*. Solar Energy, 67 (4-6), pp. 317-330.
- Blanco J. 2002. *Desarrollo de colectores solares CPC para aplicaciones fotoquímicas de degradación de contaminantes persistentes en agua*. Doctoral thesis. Ed. CIEMAT, Madrid.
- Blanco J, Malato S. 2003. *Solar Detoxification*. UNESCO Publishing, France.
- Blanco J, Malato S, Maldonado M I, Vincent M, Vincent J P, Sánchez M, Myro E. 2004. *The Albaida plant: first commercial step in solar detoxification*. Global Symposium on Recycling, Waste Treatment and Clean Technology, REWAS'04, Madrid, Spain.
- Bossmann S H, Oliveros E, Gob S, Siegwart S, Dahlen E P, Payawan L, Straub M, Wörner M, Braun A M. 1998. *New evidence against hydroxyl radicals as reactive intermediates in the thermal and photochemically enhanced fenton reactions*. Journal of Physical Chemistry A, 102 (28), pp. 5542-5550.
- Boye B. 2002. *Decontamination of chlorophenoxy acid herbicides in aqueous medium by advanced electrochemical oxidation methods using boron-doped diamond thin-layer film and O<sub>2</sub>-diffusion electrodes*. Ph.D. Thesis, Laboratori de Ciència i Tecnologia Electroquímica de Materials, Facultat de Química, Universitat de Barcelona, Spain.
- Carey J H, Lawrence J, Tosine H M. 1976. *Photo-dechlorination of PCBS in presence of titanium dioxide in aqueous suspensions*. Bulletin of Environmental Contamination and Toxicology, 16 (6), pp. 697-701.
- Degrémont. 1989. *Memento technique de l'eau*. Tome 2. Neuvième édition française, Paris.
- Devipriya S, Yesodharan S. 2005. *Photocatalytic degradation of pesticide contaminants in water*. Solar Energy Materials and Solar Cells, 86, pp. 309-348.
- Domènech X, Ayllón J A, Peral J, Rieradevall J. 2002. *How green is a chemical reaction? application of LCA to Green Chemistry*. Environmental Science and Technology, 36, 5517-5520.
- Domènech X, Jardim W, Litter M. 2001. *Procesos avanzados de oxidación para la eliminación de contaminantes*. In: Blesa M A. (Ed.). *Eliminación de contaminantes por fotocátalisis heterogénea*. Red CYTED VIII-G. La Plata, Argentina. Chapter 1.
- Domènech X. 2005. *Química Verde*. Rubes Editorial, Barcelona.
- Dunford H B. 2002. *Oxidations of iron (II)/(III) by hydrogen peroxide: from aquo to enzyme*. Coordination Chemistry Reviews, 233-234, pp. 311-318.
- Eckenfelder W W. 1989. *Industrial Water Pollution Control*. 2nd Ed. McGraw-Hill, New York, USA.
- EIPPCB. 2000. *Reference Document on Best Available Techniques in the pulp and Paper Industry*. European Commission. Institute for Prospective Technological Studies (Sevilla). Available at: <http://eippcb.jrc.es>
- EIPPCB. 2003. *Reference Document on Best Available Techniques in Common Waste Water and Waste Gas Treatment/Management Systems in the Chemical Sector*. European Commission. Institute for Prospective Technological Studies (Sevilla). <http://eippcb.jrc.es>
- EEA. 2005. *The european environment: state and outlook. Part A: Integrated assessment*. [www.eea.eu.int/main.html](http://www.eea.eu.int/main.html)

- EU. 2000. *Directive 2000/60/EC of the European Parliament and of the Council establishing a framework for the Community action in the field of water policy*. Official Journal L 327, 22/12/2000. pp. 0001-0072.
- EU.2002. *Water is life. Water Framework Directive*. Leaflet available at: [www.europa.eu.int/comm/environment/water/water-framework/index\\_en.html](http://www.europa.eu.int/comm/environment/water/water-framework/index_en.html)
- Farhataziz, Ross A B. 1977. *Selective specific rates of reactions of transients in water and aqueous solutions. Part III. Hydroxyl radical and perhydroxyl radical and their radical ions*. Natl. Stand. Ref. Data Ser. (USA Natl. Bur. Stand.), p. 59.
- Fenton H J H.1894. *Oxidation of tartaric acid in the presence of iron*. Journal of the Chemical Society, London, 65, pp. 899-910.
- Fernández-Ibáñez P, Blanco J, Malato S, de las Nieves F J. 2003. *Application of the colloidal stability of TiO<sub>2</sub> particles for recovery and reuse in solar photocatalysis*. Water Research, 37, 3180-3188.
- Fernández-Ibáñez P, Malato S, de las Nieves F J. 2004. *Propiedades coloidales de partículas de TiO<sub>2</sub>: aplicación al tratamiento fotocatalítico solar de aguas*. Ed. CIEMAT, Madrid.
- Gernjak W, Malato S, Blanco J, Alarcón D C, Maldonado M I, Fernández-Ibáñez P. 2004. *Solar photocatalytic water detoxification. Technology and application examples at pilot-plant scale*. New Challenges in Catalysis, Fourth International Seminar, Belgrade, Serbia, 5 - 8 October.
- Glaze W H, Beltrán, F J, Tuhkanen T, Kang J W. 1992. *Chemical models of advanced oxidation processes*. Water Pollution Research Journal of Canada, 27, pp. 23-42.
- Gogate P R, Pandit A B. 2004a. *A review of comparative technologies for wastewater treatment. I: oxidation technologies at ambient conditions*. Advances in Environmental Research, 8 (3-4), pp. 501-551.
- Gogate P R, Pandit A B. 2004b. *A review of comparative technologies for wastewater treatment. II: Hybrid methods*. Advances in Environmental Research, 8 (3-4), pp. 553-597.
- Haas C N. 1999. *Disinfection*. In: Letterman R D (Ed.). *Water quality & treatment. A Handbook of community water supplies*. 5th Ed, American Water Works Association, McGraw-Hill Handbooks, USA. Chapter 14.
- Haber F, Weiss JJ. 1934. *The catalytic decomposition of hydrogen peroxide by iron salts*. Proceedings of the Royal Society of London. Series A: Mathematics and Physical Sciences, 147, pp. 332-345.
- Hellweg S, Fischer U, Scheringer M, Hungerbühler K. 2004. *Environmental assessment of chemicals: methods and application to a case study of organic solvents*. Green Chemistry, 2004, 6, pp. 418-427.
- Herrmann J M. 1995. *Heterogeneous photocatalysis: an emerging discipline involving multiphase system*. Catalysis Today, 24, pp. 157-164.
- Herrmann J M. 2005. *Heterogeneous photocatalysis: state of the art and present applications*. Topics in Catalysis, 14(1-4), pp. 48-65.
- Hirvonen A, Tuhkanen T, Ettala M, Korhonen S, Kalliokoski P. 1998. *Evaluation of a field-scale UV/H<sub>2</sub>O<sub>2</sub>-oxidation system for the purification of groundwater contaminated with PCE*. Environmental Technology, 19, pp. 821-828.
- Hoffmann V H, Hungerbühler K, Mc Rae G J. 2001. *Multiobjective screening and evaluation of chemical process technologies*. Industrial & Engineering Chemistry Research, 40, pp. 2513-4524.
- Hoigné J, Bader H. 1983. *Rate constants of reaction of ozone with organic and inorganic compounds in water. part II. Dissociating organic compounds*. Water Research, 17 (2), pp.185-194.
- Hoigné J. 1985. *The chemistry of ozone in water*. Process Technologies for Water Treatment. Ed. by Stucki S. Plenum Publishing Corporation, New York, USA.
- Hoigné J. 1988. *Organic micropollutants and treatment processes: kinetic and final effects of ozone and chloride dioxide*. The Science of the Total Environment, 47, pp. 169-185.
- Klausner J F, Goswami Y D, Wyness P R. 1992. *Energy consumption of wastewater treatment technologies*. Proceedings of the ASME International Solar Energy Conference, Vol. 1, pp. 29-36.

- Konstantinou I K, Albanis T A. 2003. *Photocatalytic transformation of pesticides in aqueous titanium dioxide suspensions using artificial and solar light: intermediates and degradation pathways*. Applied Catalysis B: Environmental, 42, pp. 319-335.
- Konstantinou I K, Albanis T A. 2004. *TiO<sub>2</sub>-assisted catalytic degradation of azodyes in aqueous solutions: Kinetic and mechanistic investigations. A review*. Applied Catalysis B: Environmental, 49, pp.1-14.
- Kremer M L. 1999. *Mechanism of the Fenton reaction. Evidence for a new intermediate*. Physical Chemistry Chemical Physics, 1, 3595-3605.
- Krutzler T, Fallmann H, Maletzky P, Bauer R, Malato S, Blanco J. 1999. *Solar driven degradation of 4-chlorophenol*. Catalysis Today, 54, pp. 321–327.
- Lee C H, Yoon J Y. 2004. *Temperature dependence of hydroxyl radical formation in the hv/Fe<sup>3+</sup>/H<sub>2</sub>O<sub>2</sub> and Fe<sup>3+</sup>/H<sub>2</sub>O<sub>2</sub> systems*. Chemosphere, 56 (10), pp. 923-934.
- Legrini O, Oliveros E, Braun A M. 1993. *Photochemical processes for water treatment*. Chemical Reviews, 93, pp. 671-698.
- Link H, Turchi C. 1991. *Cost and performance projections for solar water detoxification systems*. Prepared for American Society of Mechanical Engineers (ASME), International Solar Energy Meeting, March 17–22, Reno, Nevada.
- Malato S. 1999. *Solar photocatalytic decomposition of pentachlorophenol dissolved in water*. Doctoral thesis. Ed. CIEMAT, Madrid.
- Malato S, Blanco J, Fernández-Ibáñez P, Cáceres J. 2001. *Treatment of 2,4-Dichlorophenol by solar photocatalysis: comparison of coupled photocatalytic-active carbon vs. active carbon*. Journal of Solar Energy Engineering, 123 (2), 138-142.
- Malato S, Blanco J, Vidal A, Richter C. 2002. *Photocatalysis with solar energy at a pilot-plant scale: an overview*. Applied Catalysis B: Environmental, 37, pp.1-15.
- Malato S, Blanco J, Alarcón D C, Maldonado M I, Fernández-Ibáñez P, Gernjak W. 2004. *Photocatalytic detoxification of water with solar energy. New Challenges in Catalysis, Fourth International Seminar*. Belgrade, Serbia, 5 – 8 October.
- Malato S, Blanco J, Maldonado M I. 2004. *Depuración de aguas residuales conteniendo plaguicidas mediante fotocatalisis solar*. TecnoEnergía, 36, pp. 62-71.
- Mills A, Lee S K. 2004. *Semiconductor photocatalysis*. In: Parsons S. (Ed.). *Advanced Oxidation Processes for Water and Wastewater Treatment*. IWA Publishing, London, UK. pp. 137-166.
- Nijdam D, Blom J, Boere J A. 1999. *Environmental Life Cycle Assessment (LCA) of two advanced wastewater treatment techniques*. Studies in Surface Science and Catalysis 120 B, 763-775.
- Ollis D F, Pelizzetti E, Serpone N. 1989. In: Serpone N, Pelizzetti E (Eds.). *Photocatalysis fundamentals and applications*. Wiley, p. 603.
- Ollis D F. 1991. *Solar-assisted photocatalysis for water purification: issues, data, questions*. Photochemical conversion and storage of solar energy. Kluwer Academic Publishers, pp. 593-622.
- Parsons S (Ed.). 2004. *Advanced Oxidation Processes for Water and Wastewater Treatment*. IWA Publishing, London, UK.
- Pera-Titus M, García-Molina V, Baños M A, Giménez J, Esplugas S. 2004. *Degradation of chlorophenols by means of advanced oxidation processes: a general review*. Applied Catalysis B: Environmental, 47, pp. 219-256.
- Pérez M. 2001. *Degradation of organic compounds in paper and textile industrial wastewaters by advanced oxidation processes*. Doctoral Thesis, Escola Tècnica Superior d'Enginyeria Industrial de Terrassa, Departament d'Enginyeria Química, Universitat Politècnica de Catalunya.
- Peyton G R, Glaze W H. 1988. *Destruction of pollutants in water with ozone in combination with ultraviolet radiation. Part 3. Photolysis of aqueous ozone. Mechanism of photolytic ozonation*. Environmental Science and Technology, 22 (7), pp. 761-767.

- Pignatello J J. 1992. Dark and photoassisted Fe<sup>3+</sup>-catalized degradation of chlorophenoxy herbicides by hydrogen peroxide. *Environmental Science and Technology*, 26 (5), pp. 944-951.
- Pignatello J J, Liu D, Huston P. 1999. *Evidence for an additional oxidant in the photoassisted Fenton reaction. Environmental Science and Technology*. 33 (11), pp. 1832-1839.
- Rice R G, Browning M G. 1981. *Ozone treatment of industrial wastewaters*. Noyes Data Corporation, New Jersey, USA.
- Safarzadeh-Amiri A, Bolton J R, Cater S R. 1996. *The use of iron in Advanced Oxidation Processes*. *Journal of Advanced Oxidation Technologies*, 1, pp. 18-26.
- Sagawe G, Lehnard A, Lubber M, Bahnemann D. 2001. The insulated solar Fenton hybrid process: Fundamental investigations. *Helvetica Chimica Acta*, 84 (12), pp. 3742-3759.
- Sarrià V, parra S, Adler N, Péringer P, Benitez N, Pulgarín C. 2002. *Recent developments in the coupling of photoassisted and aerobic biological processes for the treatment of biorecalcitrant compounds*. *Catalysis Today*, 76, pp. 301-315.
- Sattler C, Funken K H, Jung C, Monnerie N, de Oliveira L, Schäfer T. 2004. *Demonstration of photocatalytic waste water detoxification in textile industry*. Global Symposium on Recycling, Waste Treatment and Clean Technology, REWAS'04, Madrid., Spain.
- Scott J P, Ollis D F. 1995. *Integration of chemical and biological oxidation processes for water treatment: review and recommendations*. *Environmental Progress*, 14 (2), pp. 88-103.
- Servei d'Equipaments Esportius. 2003. *Equipaments Esportius. Full Tècnic*. Consell Català de l'Esport, Generalitat de Catalunya. <http://www16.gencat.net/esport/equipaments/full.htm>
- Sonneman G, Castells F, Schuhmacher M. 2004. *Integrated Life-Cycle and Risk Assessment for Industrial Processes*. Lewis Publishers, Florida, USA.
- Stahelin J, Hoigné J. 1985. *Decomposition of ozone in water in the presence of organic solutes acting as promoters and inhibitors of radical chain reactions*. *Environmental Science and Technology*, 19, pp. 1206-1213.
- USEPA. 1998. *Handbook on advanced photochemical oxidation processes*. Center for Environmental Research Information, National Risk Management Research Laboratory, Office of Research and Development, USEPA, Cincinnati, USA.
- Vandevivere P C, Bianchi R, Verstraete W. 1998. *Treatment and Reuse of Wastewater from the Textile Wet-Processing Industry: Review of Emerging Technologies*. *Journal of Chemical Technology and Biotechnology*, 72, pp. 289-302.
- Venkatadri R, Peters R W. 1993. *Chemical oxidation technologies – ultraviolet-light hydrogen peroxide, fenton reagent, and titanium dioxide-assisted photocatalysis*. *Hazardous Waste & Hazardous materials*, 10 (2), pp. 107-149.
- Wadley S, Waite T D. 2004. *Fenton Processes*. In: Parsons S (Ed.). *Advanced Oxidation Processes for Water and Wastewater Treatment*. IWA Publishing, London, UK. Chapter 5, pp. 111-136.
- Water Pollution Control Federation. 1984. *Wastewater disinfection, manual of practice FD-10*. Water Pollution Control Federation, Alexandria, VA, USA.

# CHAPTER 4.

## Environmental and Economic Assessment by means of Life Cycle Tools

---

*“Prejudice is a great time saver. You can form opinions without having to get the facts”*

*E. B. White*

### CONTENTS

4.1. Fundamentals of Life Cycle Assessment .....	63
4.1.1. Definition .....	63
4.1.2. History and current developments.....	63
4.1.3. Methodology.....	64
4.1.3.1. Goal and scope definition.....	65
4.1.3.2. Inventory analysis.....	65
4.1.3.3. Impact assessment.....	66
4.1.3.4. Interpretation .....	66
4.1.4. Benefits and limitations of the tool.....	67
4.1.5. Applications .....	68
4.2. LCA Applied to Chemical Products and Processes .....	69
4.2.1. Application in the background system.....	69
4.2.2. Application in the foreground system .....	69
4.2.3. Drawbacks for its application.....	70
4.2.3.1. Uncertainty and data availability .....	70
4.2.3.2. Time, cost and complexity .....	71
4.3. Streamlined LCA.....	72
4.3.1. What is “streamlining” LCA?.....	72
4.3.2. Streamlining approaches.....	72
4.3.2.1. Semi-quantitative methods .....	73
4.3.2.2. Quantitative methods.....	73
4.3.3. Reliability of streamlined LCAs.....	74
4.4. Life Cycle Costing .....	75
4.4.1. Background and current developments.....	75
4.4.2. Definitions and related terms.....	75
4.4.3. Key elements in LCC.....	76
4.4.3.1. External and internal costs .....	76
4.4.3.2. Discounting.....	77

4.4.4. Methodology.....	78
4.4.4.1. Goal and scope .....	79
4.4.4.2. Cost accounting and LCC calculation.....	80
4.4.4.3. Interpretation of results.....	80
4.5. Integration of LCA and LCC .....	81
4.5.1. Origins of the gap between LCC and LCA .....	81
4.5.2. Basic requirements for harmonization .....	81
4.5.2.1. Harmonizing the scope of the study .....	82
4.5.2.2. Harmonizing inventory analysis and cost accounting .....	82
4.5.3. Review of integration strategies .....	83
4.5.3.1. Simultaneous application.....	83
4.5.3.2. The BEES method.....	83
4.5.3.3. The BASF Ecoefficiency method.....	83
4.5.3.4. The Econo-environmental return .....	84
4.5.3.5. Monetary valuation of LCA results.....	85
4.5.3.6. Total Cost Assessment by CWRT .....	85
4.6. Previous Environmental Assessments of AOPs for Wastewater Treatment .....	87
4.6.1. LCA studies .....	87
4.6.2. Other environmental studies .....	87
4.6.3. Conclusions.....	88
References to Chapter 4 .....	89

The aim of Chapter 4 is to present the methodological tools that will be used in this thesis to assess AOPs: LCA and LCC. First, LCA is described from a methodological point of view, highlighting its applications in the chemical sector, and the possibility to use streamlining methods to make the tool more suitable during the early stages of product and process development. LCC, the economic counterpart of LCA, is then introduced. As opposed to LCA, LCC is not yet a standardized tool in the framework of sustainability assessment, and for this reason different cost accounting concepts and methodological approaches are discussed, specially with regard to how LCA and LCC must be integrated. Finally, a review is made on previous environmental assessments of AOPs through the use of LCA.



## 4.1. Fundamentals of Life Cycle Assessment

The first section of this chapter is devoted to introduce LCA as a method for environmental assessment, emphasizing its methodology but also its historical and current development.

### 4.1.1. Definition

The first international consensus on the definition of LCA was reached at the beginning of the 1990s by the Society of Environmental Toxicology and Chemistry (SETAC), which considers LCA as (Consoli et al. 1993):

*“An objective process to evaluate the environmental burdens associated with a product, process or activity by identifying and quantifying energy and materials used and wastes released to the environment, and to evaluate and implement opportunities to affect environmental improvements. The assessment includes the entire life cycle of the product, process or activity, encompassing extracting and processing raw materials; manufacturing, transportation and distribution; use; re-use, maintenance; recycling and final disposal”.*

ISO has also provided very relevant input to the process of defining and LCA. According to the ISO 14040 standard, LCA is (ISO 1997):

*“A technique for assessing the environmental aspects and potential impacts associated with a product by:*

- *compiling an inventory of relevant inputs and outputs of a product system,*
- *evaluating the potential environmental impacts associated with those inputs and outputs,*
- *interpreting the results of the inventory analysis and impact assessment phases in relation to the objectives of the study.*

*LCA studies environmental aspects and potential impacts through the product’s life cycle (from cradle to grave), from raw material acquisition to production, use, and final disposal”.*

As can be seen, both definitions are quite similar, highlighting the need of taking into account in the analysis the entire product chain and the potential consequences on the environment, based on the compilation of a mass and energy balance of the product system.

### 4.1.2. History and current developments

A general overview of LCA history and recent developments can be found in Sonneman et al. (2004). The origins of the LCA methodology can be traced to the energy crises of the late 1960s and early 1970s, which forced industries to look for energy efficient solutions for their products (Milà 2003). Several authors consider the (unpublished) study carried out in 1969 by the Midwest Research Institute (MRI) for the Coca-Cola<sup>®</sup> company to be the first LCA. This project aimed at comparing different types of drink containers, and according to Hunt and Franklin (1996) this study was one of the reasons for the company to shift from glass to plastic bottles. However, according to Assies (1992), it is the MRI’s study conducted in 1974 for the USEPA, also on the issue of drink containers, the precursor of current LCAs. Instead of the term LCA, this study and subsequent ones were called Resource and Environmental Profile Analysis (REPA). During this initial period, studies were simple and generally restricted to calculating energy requirements and solid waste.

During the 1970s, extensive energy studies based on Life Cycle Inventories (LCI) were performed for a range of industrial systems (Fava and Page 1992). By the end of the 1980s, numerous studies using LCA had been performed, mainly by private companies in Sweden, Switzerland and the USA (Huppel 1996; Udo de Haes 1993). However, these studies were performed using different methods and without a common theoretical framework.

It is in the 1990s when the application and methodological development of LCA takes off (Fullana and Puig 1997). In 1990 conferences on the subject of LCA are held in the USA and Belgium. Since this year, attempts have been made to develop and standardise the LCA methodology under the coordination of SETAC (Udo de Haes 1993). In 1993 this organization published a Code of Practice (Consoli et al. 1993), which presents general principles and a framework for the conduct, review, presentation and use of LCA findings. In 1992 the Society for the Promotion of LCA Development (SPOLD) was founded by 20 European business companies, with the goal of fostering and standardizing the use of LCA. In 1993 the ISO Technical committee 207 started working on the development of international standards of LCA, leading to the 14.04X series (Box 4.1).

Box 4.1. The ISO 14.04X series on LCA.

- ISO 14040 Environmental Management – Life Cycle Assessment – Principles and Framework (ISO 1997).
- ISO 14041 Environmental Management – Life Cycle Assessment – Goal and Scope Definition and Inventory Analysis (ISO 1998).
- ISO 14042 Environmental Management – Life Cycle Assessment – Life Cycle Impact Assessment (ISO 1999).
- ISO 14043 Environmental Management – Life Cycle Assessment – Life Cycle Interpretation (ISO 2000).
- ISO/TR 14047 Environmental Management – Life Cycle Impact Assessment – Examples of application of ISO 14042 (ISO 2003)
- ISO/TR 14049 Environmental Management – Life Cycle Assessment – Examples of application of ISO 14041 to goal and scope definition and inventory analysis (ISO 2000).

More recently, in May 2000, a joint initiative by the United Nations Environment Program (UNEP) and SETAC has been launched, called Life-Cycle Initiative (UNEP/SETAC Life-Cycle Initiative 2002), aiming at establishing the foundations for LCA methodology to be used in a practical manner by all product and service sectors at the global level (Sonneman et al. 2004).

### 4.1.3. Methodology

The ISO 14040 standard determines four basic stages for LCA studies, schematically represented in figure 4.1, and briefly described in this section.

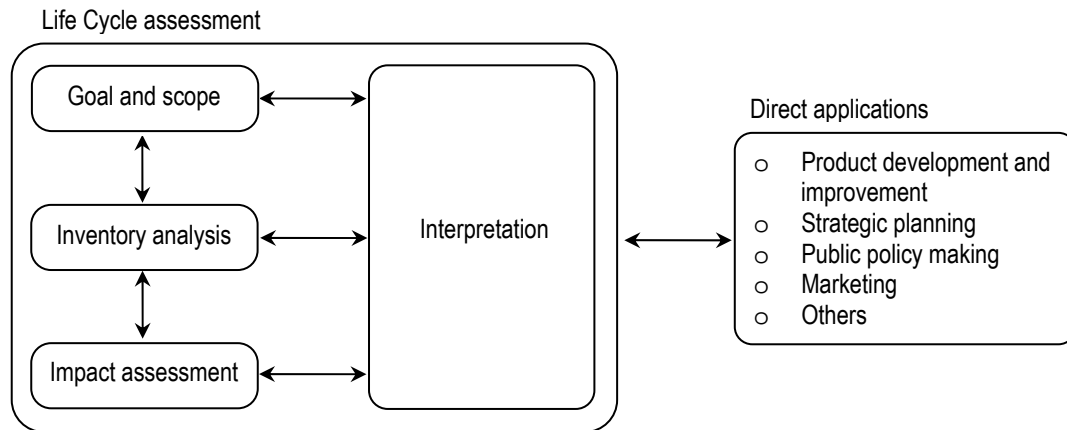

Figure 4.1. Stages in a Life Cycle Assessment. Source: ISO 1997.

#### 4.1.3.1. Goal and scope definition

This is the first stage of the study and probably the most important, since the elements defined here, such as purpose, scope, and main hypothesis considered are the key of the study.

In first place, the goal of the study is defined, as well as the reasons that have lead to its realization, the kind of decisions that will be made from the results obtained, and if these will be of internal use (for a company, for instance) or external (to inform the general public or an institution).

Secondly, the scope of the study is defined. This implies, among other elements, defining the system, its boundaries (conceptual, geographical and temporal), the quality of the data used, the main hypothesis, as well as the limitations of the study. A key issue in the scope is the definition of the functional unit (Muñoz et al. 2005a). This is the unit of the product or service whose environmental impacts will be assessed or compared. It is often expressed in terms of amount of product, but should really be related to the amount of product needed to perform a given function.

#### 4.1.3.2. Inventory analysis

The inventory analysis is a technical process of collecting data, in order to quantify the inputs and outputs of the system, as defined in the scope (ISO 1998). Energy and raw materials consumed, emissions to air, water, soil, and solid waste produced by the system are calculated for the entire life cycle of the product or service. In order to make this analysis easier, the system under study is split up in several subsystems and unit processes (Figure 4.2), and the data obtained is grouped in different categories in a LCI table.

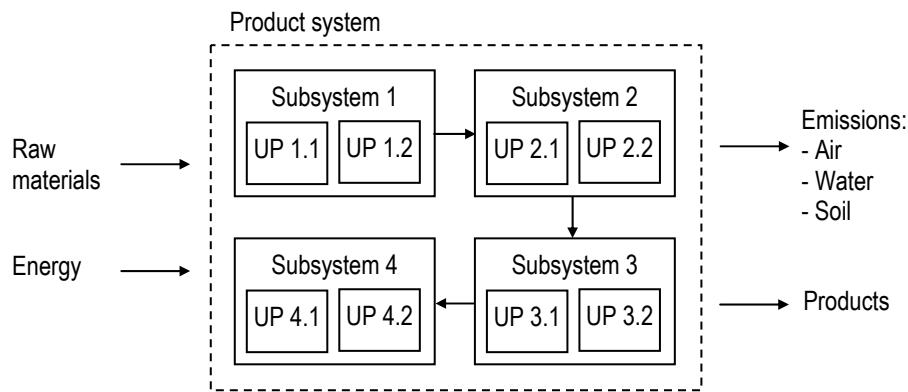

Figure 4.2. System definition in inventory analysis. UP: unit process.

#### 4.1.3.3. Impact assessment

Life Cycle Impact Assessment (LCIA) is a process to identify and characterise the potential effects produced in the environment by the system under study (ISO 1999). The starting point for LCIA is the information obtained in the inventory stage. As a consequence, the quality of the data obtained in the latter is a key issue for this assessment. LCIA is considered to consist of four steps that are briefly described below.

- The first step is Classification, in which the environmental interventions (resources consumed, emissions to the environment) identified in the inventory analysis are grouped in different impact categories or indicators, according to the environmental effects they are expected to produce. For example, CO<sub>2</sub> and CH<sub>4</sub> emissions are classified in the category Global Warming Potential.
- The second step, called Characterisation, consists of weighting the different substances contributing to the same environmental impact. For each impact category included in LCIA, an aggregated result is produced, in a given unit of measure. For example, Global Warming Potential is calculated in kg eq. CO<sub>2</sub>, from the contribution of CO<sub>2</sub> and CH<sub>4</sub> emissions, among others. At this point, the so-called environmental profile of the system is obtained, consisting of a set of indicator scores.
- The third step is Normalisation, which involves relating the environmental profile of the system to a broader data set or situation, for example, relating the system's Global Warming Potential to a country's yearly Global Warming Potential.
- The last step is Weighting, where the environmental profile is reduced from a set of indicators to a single impact score, by using weighting factors based on subjective value judgements. For instance, a panel of experts or public could be formed to weight the impact categories. The advantage of this stage is that different criteria (impact categories) are converted to a numerical score of environmental impact, thus making it easier to make decisions. However, a lot of information is lost, and reality is simplified.

#### 4.1.3.4. Interpretation

This is the last stage of an LCA study, where the results obtained are presented in a synthetic way, presenting the critical sources of impacts and the options to reduce them. Interpretation involves a review of all the stages in the LCA process, in order to check the consistency of the assumptions and the data quality, in relation to the goal and scope of the study.

#### 4.1.4. Benefits and limitations of the tool

LCA involves a holistic approach. All necessary inputs and emissions in many stages and operations of the life cycle are considered to be within the system boundaries. This includes not only inputs and emissions for production, distribution, use and disposal, but also indirect inputs and emissions – such as from the initial production of the energy used – regardless of when or where they occur. If real environmental improvements are to be made by changes in the product or service, it is important not to cause greater environmental deteriorations at another time or place in the life cycle. The power of LCA is that it expands the debate on environmental concerns beyond a single issue, and attempts to address a broad range of environmental issues, by using a quantitative methodology, providing an objective basis for decision making.

According to Guinée and coworkers (2002), the core characteristic of LCA, its holistic nature, in addition of its main strength is also its main limitation, since the broad scope of analysing the entire life cycle of products and processes can only be achieved at the expense of simplifying other aspects. Particular limitations of LCA can be summarized as follows:

- LCA addresses potential rather than actual impacts. This is due to the fact that in LCA, impacts are not specified in space and time. The ISO 14.042 standard, dealing with Life Cycle Impact Assessment, specially cautions that LCA does not predict actual impacts or assess safety, risks, or whether thresholds are exceeded. The actual environmental effects of emissions will depend on when, where and how they are released into the environment. Concerning spatial differentiation, it is possible to identify the regions where certain emissions take place, and take into account the different environmental sensitivities of these regions. However, LCA does not provide the framework for a complete Risk Assessment, in which the actual impacts associated to the operation of a facility in a specific place can be predicted. The same can be applied for the time aspect, since LCA is typically a steady- state, rather than a dynamic approach.
- The LCA model focuses on physical characteristics of industrial activities and other economic processes. Market mechanisms or other secondary effects on technological development are not included.
- LCA generally regards all processes as linear, both in the economy and the environment. Doubling the production of a material is assumed to have double impact, and the same applies for doubling the release of a pollutant to the environment. Although some progress is being made in reducing this limitation, LCA at its core is based on linear modeling.
- LCA focuses on environmental issues associated to products and processes, excluding economic and social consequences. Where economic aspects are concerned, LCC can be expected to become a standard addition to LCA applications, being this thesis an example. However, the inclusion of social issues into LCA or the integration of LCA with tools for social assessment is still in its infancy.
- Finally, availability of data is another limitation. Databases are being developed in various countries, but in practice, data are frequently obsolete, incomparable, or of unknown quality.

Clearly no single tool can provide answers to all the questions posed by environmental issues. The limitations of LCA highlight the fact that in order to fill these gaps, other analytical tools, such as those described in chapter 2, must be added to given decision situations.

## 4.1.5. Applications

LCA can be used to fulfill the following objectives (Azapagic 2002):

- To provide a picture as complete as possible of the interactions of an activity with the environment.
- To identify major environmental impacts and the life-cycle stages or “hot-spots” contributing to these impacts.
- To compare environmental impacts of alternative products, processes or activities.
- To contribute to the understanding of the overall and interdependent nature of the environmental consequences of human activities.
- To provide decision makers with information on the environmental effects of these activities and identify opportunities for environmental improvements.

These objectives have governed the use of LCA in both private companies and public agencies. As an example, table 4.1 gives an overview of the contexts in which LCA is used by different stakeholders.

Table 4.1. Overview of LCA applications.

Active party	Application	Example
Authorities	Community action plans	<ul style="list-style-type: none"> <li>○ Incineration vs. recycling of paper</li> <li>○ Recyclable glass bottles vs. other beverage containers</li> <li>○ Ranking of industrial products</li> </ul>
	Environmentally conscious public purchase	<ul style="list-style-type: none"> <li>○ Cars, work clothes, canteen service, office furniture</li> </ul>
	Consumer information	<ul style="list-style-type: none"> <li>○ Ecolabelling</li> </ul>
Company	Establish environmental focus	<ul style="list-style-type: none"> <li>○ Identification of areas of improvement</li> <li>○ Product-oriented environmental policy</li> <li>○ Environmental management</li> </ul>
	Design choices	<ul style="list-style-type: none"> <li>○ Choice of concept</li> <li>○ Choice of component</li> <li>○ Choice of material</li> <li>○ Choice of process</li> </ul>
	Environmental documentation	<ul style="list-style-type: none"> <li>○ Environmental information to consumers</li> </ul>
Consumer organizations and other associations of interested parties	Guidance to environmentally conscious consumption	<ul style="list-style-type: none"> <li>○ Ecolabelling</li> </ul>
	Life cycle assessment of community actions	<ul style="list-style-type: none"> <li>○ Ecological or conventional farming, transport systems</li> </ul>

Source: Wenzel et al. (1998).

Historically, most of the LCA applications have been product-oriented, encompassing a broad range of products. The earlier studies focused on consumer products such as beverage packaging, washing machines and detergents, while since the 1990s the tool has been applied to products from several industrial sectors: energy, metals and minerals, polymers, paper, textile and leather, electronic, manufacturing, agriculture, food, drinks, and also chemicals (Azapagic 2002). Apart from direct product applications, LCA can also be used in a wider sense. Rather than dealing with physical goods, LCA can be applied to assess processes, business strategies or government policies, like comparing different waste management strategies, different types of biomass use, or one-way vs. reusable packaging by an industry (Guinée et al. 2002).

## 4.2. LCA Applied to Chemical Products and Processes

The suitability of LCA as a tool for environmental evaluation of chemical products and processes has been suggested by several authors involved in the development and promotion of Green Chemistry (Lankey and Anastas 2002; Anastas and Lankey 2000; Domènech et al. 2002; Domènech 2005; Yasui 2003; Graedel 1999; Hellweg et al. 2004; Sikdar 2003). The tool is well known by the chemical industry, which uses it for product and process development, marketing, and communication with public authorities and clients, among other purposes (Fullana and Puig 1997). In this section several issues are included: first, the role of the chemical sector when carrying out LCA studies on other sectors is highlighted. Next, a brief review on case studies applied to chemical products and processes is made, as well as discussion on the drawbacks for LCA application in this context.

### 4.2.1. Application in the background system

The chemical industry is a basic pillar for the application of LCA, not only to its own products and processes, but to any other sector's. This is due to the fact that chemicals are used as components or intermediates in most market products (Fullana and Puig 1997). As a consequence, inventory data from common chemical products, are needed in almost any LCA study, to be used as basic blocks on which the life cycle of a wide range of products is built. In these studies, chemicals are said to be part of the "background system" (Tillman 2000; Clift 2005), that is, the part of the system providing basic materials and services, like metals, plastics, fuels, electricity, or transports, among others.

In this way, LCIs of chemicals are among the typical contents of LCA databases, such as Ecoinvent (Frischknecht et al. 2004), a LCA database developed in Switzerland, which is used in chapters 5 and 6 of this thesis. This commercial database contains more than 200 datasets corresponding to the category of chemical products, divided into organic and inorganic chemicals (Althaus et al. 2004). In these databases, chemical products are inventoried applying "cradle to gate" boundaries, which means that only the first half of the life cycle is included: from raw material extraction (cradle) until the product is ready to be sold in the market (gate). The following stages in the life cycle, namely distribution, use and end of life as waste, are excluded. This is common not only for chemicals, but for all basic materials, and is due to the fact that as these materials will be incorporated in a wide range of products, the data concerning distribution, use, and end of life is specific for each LCA study and must be selected and introduced by the LCA practitioner.

### 4.2.2. Application in the foreground system

Concerning specific application of LCA in the chemical sector, several companies have applied the tool on a regular basis to their products (Fullana and Puig 1997): Du Pont de Nemours, Dow Chemical, Dow Corning, Rhône Poulenc, Procter & Gamble, Ciba Specialty Chemicals, and also GlaxoSmithKline in the pharmaceutical sector. A special remark has to be made on the method developed by BASF (Saling et al. 2002; Shonnard et al. 2003; Tiemi and Anderi 2005), called Eco-efficiency analysis. This method combines the use of LCA, a simplified Risk Assessment and LCC to compare product and process alternatives. More details on this method can be found in section 4.5.

In addition to comparing the performance of physical products, LCA can also find utility in process evaluation. However, the potential of the tool in this field has not been recognised until recently (Azapagic 2002; Burgess and Brennan 2001). With regard to processes, LCA can be used for:

- Technology assessment and process selection

- Process optimisation

Technology assessment is an analytical tool used to help understand the likely impacts of the use of a new technology, including an examination of economic benefits, costs, along with its environmental, social and political impacts. Technology assessment includes within its boundaries the development of the technology (identification of the problem, choice of alternatives, design, etc.) as well as its life cycle. It is argued that LCA can be used to assess the impacts of the latter, since up to date only site-specific impacts are taken into account. In a similar way, LCA can be used for process selection, that is, identifying Best Available Techniques (BAT). The life cycle approach is of great importance in the framework of the EU Directive on Integrated Pollution Prevention and Control (IPPC) (EU 1996), requiring the BAT to be identified by including indirect emissions, waste and resource consumption (EIPPCB 2005). Some examples of LCA applied for chemical process assessment can be found in Marquevich et al. (2002), Kniel et al. (1996) and Domènech et al. (2002).

Another process-oriented application of LCA is process optimisation, consisting of finding the optimum improvement strategy for a system, when a number of often conflicting objectives exist. The optimisation problem in the context of LCA is equivalent to a conventional optimisation model except that in addition to an economic function, also environmental objectives are involved, represented by the impacts. Therefore, the optimisation model becomes multi-objective. Examples of application to chemical processes can be found in Azapagic and Clift (1999) and Hugo et al. (2004).

### 4.2.3. Drawbacks for its application

Although it is a very promising approach for supporting decision making in Green Chemistry and engineering, several difficulties have been identified in applying LCA to chemical products and processes. Although these drawbacks are discussed in this section in the context of the chemical sector, it seems that they are basically the same problems encountered in any other application.

#### 4.2.3.1. Uncertainty and data availability

The most recurring argument in the literature concerning the difficulties in applying LCA in Green Chemistry is the lack of appropriate data during early stages of product and process development (Heinzle et al. 1998). All authors realize the importance of carrying out environmental assessments at the design stage, since the degrees of freedom are higher and therefore also the opportunities for environmental optimization. The problem is that LCA requires detailed inventory data, which in early design stages is usually incomplete and many parameters are uncertain (Hoffmann et al. 2001), making a full application only possible when the technology or the chemical is at an advanced stage of development or even available in the market. In order to overcome this problem, some methods for inventory data estimation have been suggested (Jiménez-González et al. 2000; Geisler et al. 2004). Another difficulty pointed out by Lankey and Anastas (2002) is that often laboratory researchers might not realize what data would be of interest to a LCA practitioner, and so such data might not be noted or reported. Finally, the lack of data is not only a problem in the inventory phase, but also in LCIA, since many chemicals are not included or poorly modeled in standard LCIA methods, specially in toxicity-related impact categories (Hellweg et al. 2003).



#### 4.2.3.2. Time, cost and complexity

As Mike Lancaster points out (Lancaster 2002), performing a full LCA is time-consuming, costly and a complex process. These features make LCA an impractical tool to use on a day-to-day basis for research and development chemists and chemical engineers. This is something that has been already discussed in chapter 2 (section 2.3.4) for different tools, and it is clear that only simple indicators can be used for easy and quick screening on a daily basis. Nevertheless, the possibility exists of applying LCA in a simplified or “streamlined” way, as it is discussed in the next section.

### 4.3. Streamlined LCA

The cost, time required, as well as the difficulties in gathering all the necessary data are the main drawbacks for carrying out a complete LCA study. Some have arisen the question of whether the LCA community has established a methodology which in practice is beyond the reach of most potential users, “green” chemists and chemical engineers included. This has encouraged practitioners to investigate the possibility of “streamlining” LCA to make it more feasible and more immediately relevant, without losing the key features of a life cycle approach (Todd and Curran 1999).

#### 4.3.1. What is “streamlining” LCA?

The term “streamlined” is used in the LCA context as a synonymous with “simplified”. Hence, a streamlined LCA is a simplified variety of detailed LCA, in which the scope, cost, and effort required is reduced (Hochschorner and Finnveden 2003; Todd 1995). However, the border between detailed and streamlined LCA is not straightforward. In fact, according to Graedel (1998), a complete, quantitative LCA has never been accomplished, nor is it likely to be. This implies that, for all practical LCA studies, some form of streamlining is essential for feasibility; LCA practitioners do not decide whether to streamline, but where and how to streamline. Streamlining is, therefore, a disciplined process of designing an LCA study to gather enough information in order to make a sound decision (Todd and Curran 1999).

#### 4.3.2. Streamlining approaches

LCA practice is performed along a spectrum of detail (figure 4.3). A complete LCA is considered to include all the relevant life cycle information in a quantitative manner. Streamlining can be based on increasing the amount of qualitative or semi-quantitative data used; this process progressively leads to applying Life Cycle Thinking rather than LCA, that is, the concept instead of the tool. On the other hand, streamlining can be based on excluding processes or stages in the life cycle, but keeping the quantitative nature of the tool; in this case some point is reached where we can no longer call such studies LCAs, but environmental assessments, environmental audits, etc. In this section, methods based on these two approaches are presented and discussed.

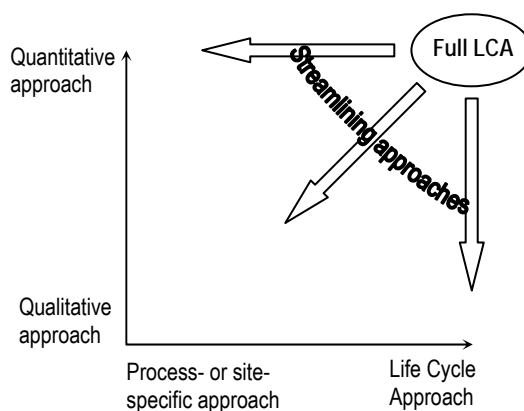

Figure 4.3. LCA falls along a spectrum of detail, concerning the extent to which quantitative and life cycle information is included.

#### 4.3.2.1. Semi-quantitative methods

Streamlining approaches challenging the need for a complete and quantitative inventory of material and energy flows have been developed. Users of LCA information might not be interested in the detailed quantities themselves, but rather on the relative differences among alternatives under study, or in identifying critical aspects in the life cycle in a qualitative way. Two main such alternative approaches have been developed, namely the Environmentally Responsible Product Assessment Matrix (ERPA) method (Graedel 1996), and the MECO method (Pommer et al. 2001). Both methods are based on the use of matrices, in which life cycle stages are confronted to environmental issues (materials, energy, residues, etc.) and given qualitative or semi-quantitative values. A comparative evaluation of these two methods can be found in Hochshorner and Finnveden (2003).

#### 4.3.2.2. Quantitative methods

Quantitative streamlining approaches are those aiming at limiting the amount of data or information needed to carry out the study, but keeping it within the existing LCA framework. Typically, this has been done by simplifying the inventory phase, by excluding life cycle stages, reducing the amount of data to collect from unit processes, etc. A summary of these approaches is shown in table 4.2. Streamlining can also affect the LCIA phase, for example just by excluding it, or using a limited number of impact categories. Detailed guidelines on how to simplify each phase of a LCA study can be found in the Dutch LCA guide (Guinée et al. 2002).

Table 4.2. Summary of quantitative streamlining approaches.

Streamlining approach	Application procedure
Removal of upstream components	All processes prior to final material manufacture are excluded. Includes fabrication into finished product, consumer use, and post-consumer waste management.
Removal of partial upstream components	All processes prior to final material manufacture are excluded, with the exception of the step just preceding final material manufacture. Includes raw materials extraction and precombustion processes for fuels used to extract raw materials.
Removal of downstream components	All processes after final material manufacture are excluded.
Removal of up- and down-stream components	Only the manufacture is included, that is, materials and energy used in this stage of the life cycle. Sometimes referred to as a "gate-to-gate" analysis.
Specific entries used to represent impacts	Selected entries are used to approximate results in the impact categories, based on mass and subjective decisions; other entries within each category are excluded.
Specific entries used to represent LCI	Specific entries from the individual processes comprising the LCI that correlate highly with full LCI results are searched for; other entries are excluded.
Use of qualitative or less accurate data	Only dominant values within each of 6 process groups (raw materials acquisition, intermediate material manufacture, primary material and product manufacture, consumer use, waste management, and ancillary materials) are used; other values are excluded, as are areas where data can be qualitative, or otherwise of high uncertainty.
Use of surrogate processes	Selected processes are replaced with apparently similar processes based on physical, chemical, or functional similarity to the datasets being replaced.
Limit raw materials	Raw materials or product components comprising less than a given percentage by mass of the product totals are excluded.

Source: Adapted from Hunt et al. (1998).

### 4.3.3. Reliability of streamlined LCAs

There is no objective standard against which to compare streamlining approaches to determine their validity (Todd and Curran 1999). What is usually done, either for semi-quantitative or quantitative streamlined studies, is to take a detailed LCA as reference, in order to see to what extent their findings match. This involves assuming that detailed LCAs are more reliable, something debatable according to Todd and Curran (1999) and Hochshorner and Finnveden (2003). Since detailed LCAs require more data inputs, can also contain more estimations and uncertainty than a streamlined LCA.

With regard to semi-quantitative LCAs, rather than finding out if their results are in accordance with complete studies, Hochshorner and Finnveden (2003) conclude that the former are complementary tools to the latter, mainly as a previous screening tool to a complete study. However, it is highlighted the fact that semi-quantitative methods are more useful in the identification of life cycle “hotspots” than in making comparisons between products, as this is much easier when quantitative data is available.

With regard to quantitative approaches, they do not usually provide with identical results as compared to detailed studies. This was found by Hunt and coworkers (1998), who applied the approaches summarised in table 4.2 to 20 different products. Only those approaches excluding the least amount of data or processes were succesful in identically ranking the different products.

In Green Chemistry, streamlining approaches will be very often needed in order to assess products and processes by means of LCA. AOPs, as emergent technologies for which most of the data available is found at the laboratory or pilot scale, constitute a clear example of this need. However, it remains necessary to determine whether decisions made on the basis of uncertain or incomplete laboratory data correlate well with the decisions that would have been made at a later stage, when processes are applied at commercial scale and more information is available. This issue is of particular interest in this thesis, as has been stated in the objectives, and will be discussed in chapter 7, based on the results obtained in the case study on AOPs.

## 4.4. Life Cycle Costing

An ideal sustainability toolbox based on life cycle concepts, also called Life Cycle Management (LCM) toolbox, should include a tool for every pillar of sustainability: an environmental tool, an economic tool, and a social tool. So far, only the environmental component is standardized by means of LCA. The other extreme is represented by the Social Life Cycle Assessment (O'Brien et al. 1996), a subject which has not advanced over the past decade, but is currently re-gaining attention and is considered as a critical future issue (Klöpffer 2003). In the middle of these situations we find LCC, which is expected to become in the near future a standard addition to LCA (Guinée et al. 2002), in order to evaluate the economic implications of a product's life cycle. In this section an introduction to this tool is made.

### 4.4.1. Background and current developments

Traditionally, acquisitions of capital items were (and are being) simply based on purchase cost, instead of on the total lifetime costs (Woodward 1997). The first life cycle approaches to economic issues have their roots in the evaluation of acquisitions of high cost military equipment (Sherif and Kolarik 1981), and also in the building industry (Fuller and Petersen 1995), for which even a specific standard has been developed by the American Society for Testing and Materials (ASTM) (ASTM 1999). Nevertheless, at present LCC cannot be called a uniform concept or framework, since there are many approaches, differing in goal, scope, data format, reporting, etc. Therefore, there is a need to develop the methodological background and application procedures of LCC as a tool for Life Cycle Management. To tackle this challenge, in december 2002 a SETAC Europe Working Group was launched on this topic, having as final purpose the development of an LCC Code of practice (Rebitzer and Seuring 2003; Hunkeler and Rebitzer 2005).

### 4.4.2. Definitions and related terms

According to Hunkeler and Rebitzer (2005), the SETAC Europe working group on LCC has adopted the following definition, which was previously suggested by the same authors (Rebitzer and Hunkeler 2003):

*“LCC is an assessment of all costs associated with the life cycle of a product that are directly covered by any one or more of the actors in the product life cycle (supplier, producer, user/consumer, end-of-life actor), with complimentary inclusion of externalities that are anticipated to be internalized in the decision-relevant future”.*

Aspects to be highlighted from this definition are, on the one hand, the fact that costs must be taken account even if the decision maker is not directly responsible for them. For example, a product manufacturer should include in an LCC study the costs incurred by the user of his product. On the other hand, it is important to note that only externalities expected to be internalized in the future by means of taxes or other regulatory measures must be included. The issue of externalities is one of the most controversial in environmental accounting, and is further discussed in section 4.4.3. Finally, it is noticed that this definition does not mention whether or not costs are expressed in present value. This is another interesting issue to be discussed in section 4.4.3.

Due to the lack of standardization, it is usual to find in the literature different terms related to life cycle approaches and/or environmental accounting. Sometimes different terms are used as synonymous, while other times the same term is used for different approaches, causing some confusion. An attempt to define commonly used terms is summarised in table 4.3.

Table 4.3. Commonly used environmental accounting terms.

Term	Definition
Environmental cost accounting	Refers to the addition of environmental cost information into existing cost accounting procedures and/or recognizing embedded environmental costs and allocating them to appropriate products or processes.
Full cost accounting	Desirable environmental accounting practices with the identification and assignment of all costs. In management accounting, full costing means the allocation of all direct and indirect costs to a product or product line for the purposes of inventory valuation, profitability analysis, and pricing decisions.
Full cost environmental accounting	Same concept as full cost accounting, but highlights the environmental and possibly health and safety elements.
Total cost accounting	Synonym for full cost environmental accounting; appears to have origins with environmental professionals.
Total cost assessment	Integrating environmental costs into a capital budgeting analysis. The long-term, comprehensive financial analysis of the full range of private costs and savings of an investment. The acronym is the same as for total cost accounting (TCA).
True cost accounting	Another synonym for full cost accounting. As defined by the USEPA, this term encompasses both private and societal costs, where full cost accounting encompasses costs that affect the bottom line.
Cost-benefit analysis	Describes and quantifies the social advantages and disadvantages of a project in monetary units. If benefits exceed costs, the project is accepted, regardless of how costs and benefits are distributed (Kaldor-Hicks criterion).
Cost-effectiveness analysis	Determines the least cost option for a predetermined environmental target, or conversely, the option involving the greatest environmental improvement for a given expenditure.
Life cycle cost assessment	Evaluation of life cycle costs of a product, product line, process, system or facility by identifying environmental consequences and assigning monetary value to these consequences.
Life cycle accounting	Assignment and analysis of product-specific costs within a life cycle framework.
Life cycle cost	Total of the direct, indirect, recurring, non-recurring, and other related costs incurred by or estimated for the project in the design, development, production, operation, maintenance, and support of a major system over its anticipated useful life span.
Life Cycle Assessment, Life Cycle Analysis	Identifying the environmental consequences of a product, process or activity through its entire life cycle and opportunities for achieving environmental improvements. Focuses on environmental impacts, not costs.

Sources: USEPA (1995), except for Cost-benefit analysis, adapted from Pearce (1971) and Pasqual (1998), and Cost-effectiveness analysis, adapted from Tietenberg (1992).

#### 4.4.3. Key elements in LCC

Among the most controversial and discussed issues in LCC and environmental accounting in general we find the following: whether or not include external costs, and the need to discount future costs to present value.

##### 4.4.3.1. External and internal costs

There are two main categories of costs (figure 4.4):

- Internal costs, also called private costs, are those appearing in company's accounts, as well as those incurred by consumers or other stakeholders. These costs have a clear market value. In this group we find conventional costs (materials, fuels, labor, equipment, etc.) and potentially hidden and less tangible costs, which are usually assigned to overhead in company's accounts (permits, post-closure care, liability costs, etc.).
- External costs, also called social costs, societal costs, or externalities, are the monetized effects of environmental and social impacts caused by products and services, for which a company, consumer or another stakeholder is not obliged to pay, since neither the marketplace nor regulations assign such costs to a particular person or activity. Examples of these costs are increased risk of asthma resulting from air pollutants or the expected impacts on global climate due to emissions of greenhouse gases.

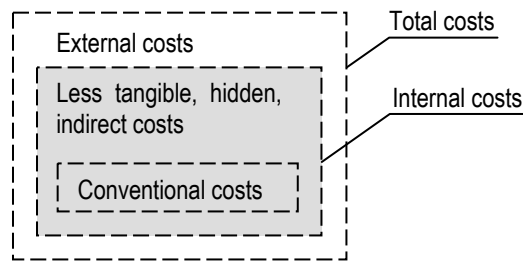

Figure 4.4. Cost boundaries. Source: Adapted from Shapiro (2001).

In an ideal scenario, where all externalities would be internalized via taxes and subsidies, the economic system could be used as a simplification for the complete social and natural system. In such a case, LCC would provide all the necessary information for sustainability assessment (Rebitzer and Hunkeler 2003). The problem is that, in practice, not all external costs are covered by tax and subsidy mechanisms, thus they are consequently excluded from monetized accounting. Nevertheless external costs are real, and are borne by society as a whole, but since they are related to goods that are not traded in traditional markets, they do not have a clear market value. Assigning a monetary value on goods such as a beautiful landscape or even human life is not only difficult, but also ethically questionable. In spite of this, other tools for economic assessment of projects, namely cost-benefit analysis, involve the monetization of all costs and benefits, regardless of whether they are internal or external.

Attending to the LCC definition by the SETAC working group given above, it has been decided that, in the context of Life Cycle Management, or sustainability assessment, LCC should not include external costs, with the exception of those which are expected to be internalized in the decision-making time horizon. The reasons to do this are (Rebitzer and Hunkeler 2003; Klöpffer 2003): a) the refusal to monetize externalities due to the aforementioned reasons, and b) if externalities were monetized, a double-counting problem would appear when using LCC and LCA, as externalities would be expressed in monetary units and physical units (impact category indicator results). Further discussion on how to integrate LCC and LCA can be found in section 4.5.

#### 4.4.3.2. Discounting

The discount rate is the interest rate used in economic sciences to find the present value of future costs and benefits. There are several reasons for valuing one monetary unit differently at different points of time (Schmidt 2003; Hellweg et al. 2003; Fuller and Petersen 1995):

- Productivity of capital: cash amounts received earlier can be reinvested earlier thereby earning additional returns.
- Uncertainty and risk: project costs or revenues taking place in the future are assumed to do so, involving a certain degree of uncertainty, specially for risky projects.
- Time preference: in other words, impatience of the person, company or society.

By means of a properly chosen discount rate, the investor becomes indifferent between cash amounts received at different points of time (Fuller and Petersen 1995). In economics, the Net Present Value (NPV) of an investment is calculated as function of benefits, costs, and the discount rate (equation 4.1):

$$NPV = \sum_{t=0}^T \left[ (B_t - C_t) \cdot \frac{1}{(1+r)^t} \right] \quad (4.1)$$

Where:

$B$  represents the benefits,

$C$  represents the costs,

$r$  is the discount rate, expressed in real terms, net of any changes in the price level (inflation),

$t$  is the time horizon of the project.

As an example, 1 € invested today at an interest rate of 5% will have value of 1.6 € in ten years. Conversely, 50 € obtained in 20 years have a present value of 18.8 €, which means at the same time that in order to obtain 50 € in twenty years, we need to invest 18.8 € today, at an interest rate of 5%. The selection of the discount rate can be crucial in LCC: a high discount rate will favour options with low capital costs, short life and high recurring cost, and viceversa (Woodward 1997). The choice is controversially discussed when projects in the public sector are dealt with, or if the duration of the project is long, due to the fact that future costs are reduced so much that many people feels that it fails to take into account the interests of future generations (Costanza 1991). This discussion involves the question whether the private or the social discount rate must be used:

- The private discount rate can be observed on the financial markets; a typical value in the EU would be between 5% and 7% per year, although some companies can use values above 10% (Hellweg et al. 2003).
- The social discount rate is the interest rate at which society is willing to lend money for public projects. It is in practice smaller than the private discount rate, among other reasons because public projects are less risky than private ones. However, it is suggested that even lower values should be used in order to keep intergenerational equity (Rabl 1996).

According to Schmidt (2003), if the LCC is excluding externalities and the time scale of the product or service is usually shorter than that of the customer, the discounting issue is not a question of intergenerational equity, and the private discount rate can be used. However, it is always recommended to carry out sensitivity analyses in order to check the influence of this parameter on the study results.

#### 4.4.4. Methodology

As has been already discussed, a standard methodological framework for LCC as a tool for Life Cycle Management is being prepared by a SETAC working group. Until this work is finished, the only standardized methodology available up to date is that applied to building systems (ASTM 1999). In this section the latter is briefly described, based on the Handbook by the US National Institute of Standards and technology (NIST) (Fuller and Petersen 1995), which is entirely consistent with the ASTM standard. A discussion on how this framework should be harmonized with LCA is included in section 4.5.

As can be seen in box 4.1, the NIST framework for LCC studies includes 10 steps, which could be grouped into three phases: steps 1 to 3 could be defined as the goal and scope of the study, steps 4 to 7 correspond to the calculation of LCC, and finally steps 8 to 10 correspond to the interpretation of the results and drawing of conclusions. All these elements are introduced below.



Box 4.1. Key steps in LCC analysis of building systems.

1. Define problem and state objective
2. Identify feasible alternatives
3. Establish common assumptions and parameters
4. Estimate costs and times of occurrence for each alternative
5. Discount future costs to present value
6. Compute and compare LCC for each alternative
7. Compute supplementary measures if required for project prioritization
8. Assess uncertainty of input data
9. Take into account effects for which dollar costs or benefits cannot be estimated
10. Advise on the decision

Source: Fuller and Petersen 1995.

#### 4.4.4.1. Goal and scope

The first step in an LCC study is to identify what has to be analyzed, and the type of decision to be supported. The project or system under study should be described including both general aspects as well as technical information and regulatory constraints. The type of investment decision to be made can include: accepting or rejecting a project, relative with not undertaking it, selecting the optimal efficiency level for a system, selecting the optimal system from competing alternatives, ranking competing projects to allocate a limited budget, etc.

Once the overall project has been described, the next step is to identify all technically sound and practical alternatives, which must be considered equivalent in terms of functionality and must satisfy the technical performance specifications set out in the project description.

Next, several parameters involved in the LCC calculations must be set. Some of these parameters are relative to the project lifetime (figure 4.5): the study period is the time over which the costs and benefits related to a capital investment decision are of relevance to the investor; it begins with the base date and includes the planning and construction period (if any) and the service period, where the benefits and operation costs of the project take place. On the other hand, the base date is the point in time to which all project-related costs and benefits are discounted in the study, while the service date is the date on which the project is expected to be implemented. When there is no planning and construction period, or it is neglected, the base date and the service date coincide (figure 4.5 left). It is important to note that both the study period and the base date must be the same for all the alternatives under study.

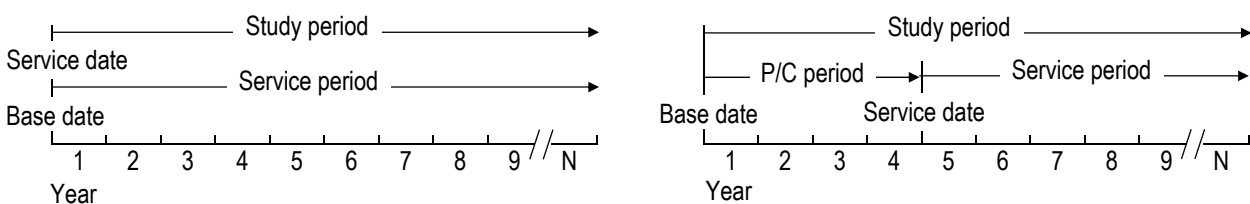

Figure 4.5. Coinciding study period and service period (left); phased-in planning and construction period (right). Source: Fuller and Petersen 1995.

Other important aspects to be defined are the discount rate to be used, whether nominal (inflation included) or real prizes (inflation excluded) will be used, operational assumptions, etc.

#### 4.4.4.2. Cost accounting and LCC calculation

Prior to calculate the life cycle cost of the alternatives, the different cost categories must be identified and quantified, distinguishing on the one hand between single costs and annually recurring costs, and on the other hand between initial costs (investment) and future costs (operation, maintenance, disposal). Possible revenues must be treated in the same way. All these costs and benefits must be quantified for all alternatives under study, discounted to its present value (equation 4.1), and aggregated, in order to obtain the life cycle cost.

In addition to the life cycle cost, other supplementary measures of economic performance can be calculated, such as the net savings, the savings-to-investment ratio, the adjusted internal rate of return, the discounted payback period, and the simple payback period.

#### 4.4.4.3. Interpretation of results

Once the results are obtained, it makes sense to check their validity. As in any other model, LCC involves a given degree of uncertainty with regard to several parameteres: project life, operation and maintenance costs, discount rate, among others. Two deterministic approaches are suggested to deal with uncertainty:

- Sensitivity analysis: a technique to determine which input values, if different, would make a crucial difference to the outcome of the study. This analysis is performed just by varying uncertain input values (one at a time), recalculating the life cycle cost, and looking at the resulting change with regard to the original results.
- Breakeven analysis: for a given variable, the breakeven value is the point where there is neither gain or loss, with respect to a reference situation or alternative. For example, finding out what is the minimum amount of energy savings needed by an energy-saving system in a building in order to offset initial investment cost, thus obtaining a lower life cycle cost with regard to the existing situation. This technique requires expressing life cycle cost as a function of the variable under analysis, and solving the equation algebraically.

## 4.5. Integration of LCA and LCC

In most applications of LCA, the decision making situation must also take into account the economic consequences of alternatives. In the previous section LCC has been suggested as the complementary tool to address economic aspects of a life cycle. However, up to date no standards exist on how to integrate both tools. In this section the methodological differences between LCA and LCC are analysed, and a review of suggested methods for integration is made.

### 4.5.1. Origins of the gap between LCC and LCA

The probable reason why economic analysis has not yet been well-addressed by LCA, according to Norris (2001), is that, despite the similarity of their names, LCA and LCC have major methodological differences, which are summarised in table 4.4.

Table 4.4. Differences between LCA and LCC.

Aspect	LCA	LCC
Objective	Compare relative environmental performance of alternative product systems for meeting the same end-use function, from a broad, societal perspective.	Determine cost effectiveness of alternative investments and business decisions, from the perspective of an economic decision maker such as a manufacturing firm or a consumer.
Activity scope of the addressed life cycle	Supply chain of processes supporting usage phase; entire physical usage.	Activities directly causing costs or benefits to the decision maker during the economic life of the investment as a result of the investment
Flows considered	Pollutants, resources, and interprocess flows of materials and energy.	Direct costs and benefits to decision maker.
Units for tracking flows	Physical and energy units.	Monetary units (e.g., yen, dollars).
Time treatment and scope	Timing ignored; all causally linked flows, and some of their impacts, collapsed in time and valued equally regardless of timing.	Timing is critical; present valuing (discounting) of costs and benefits; specific time-horizon scope, outside of which costs and benefits are ignored.

Source: Norris (2001).

The basic difference is that each tool is designed to answer different questions, that is, they have different objectives, as can be seen in table 4.4. These differences in purpose lead to differences in scope and method: LCA focuses on the physical life cycle, while for LCC the life cycle is usually the “economic lifetime”, which is set by accounting conventions or by the decision maker. Some aspects of LCA that are absent in LCC include: physical flows that have no direct costs for the decision maker, and flows/processes taking place outside the “economic lifetime”. On the other hand, key factors of LCC that are absent in LCA include: cash flows not linked to physical flows (investments, labor, etc.), the timing of cash flows, discounting, and the risk of incurring costs.

### 4.5.2. Basic requirements for harmonization

Because of the differences discussed above, before applying LCA and LCC for sustainability assessment it seems necessary to harmonize several methodological elements of both tools. In this section the most remarkable issues are discussed, at two levels: scope of the study and inventory analysis.

#### 4.5.2.1. Harmonizing the scope of the study

Fully integrating LCC with LCA requires going beyond simply treating economic cost as just another flow, or as another property of flows. Instead, the scope of the environmental and economic evaluations has to be defined in a coherent manner so as to enable comparison. The main requirements for harmonizing the scope of an LCA-LCC study are the following:

- To consider the same functional unit: it seems a basic requirement that both physical and cash flows be related to the same functional unit (Klöpffer 2003; Carlsson 2005; Rebitzer et al. 2003).
- To consider the same system boundaries: as with the functional unit, environmental impacts and costs can only be related to each other if both have similar system boundaries. (Schmidt 2003; Rebitzer et al. 2003; Klöpffer 2003; Carlsson 2005; Rebitzer and Hunkeler 2003). In particular, both tools must consider the physical life cycle of the product or process, as it is done in LCA, instead of the “economic lifetime” usually considered in conventional LCC.
- The LCC must consider costs with no direct relationship with physical flows typically included in LCI (Norris 2001; Rebitzer 2003). These costs include, among others: investments, labor, patents, marketing, etc.

An issue which is not discussed in the literature reviewed, and remains to be solved is how to deal with discounting when applying an integrated LCA-LCC study. The definition of LCC by the SETAC working group does not mention the terms “discounting” or “net present value”, but it has been shown that discounting is a typical practice in economic analysis. On the other hand, LCA should not in principle discount future environmental impacts, as one of the strengths of the tool is to avoid “problem shifting”, in geographic and temporal terms (Guinée et al. 2002); nevertheless, it has to be admitted that sometimes LCI and/or LCIA implicitly involves discounting (Hellweg 2003; Huijbregts et al. 2001). Current practice seems to consist of discounting future costs in LCC, and apply the conventional LCA methodology without explicitly discounting future impacts (Schmidt 2003; Rebitzer et al. 2003; Sampattagul et al. 2004). A standard procedure, however, will not be available until the SETAC deliverable on LCC is published.

#### 4.5.2.2. Harmonizing inventory analysis and cost accounting

Integrating LCC and LCA is more than just applying market prices to physical flows. As it has been stated above, the LCC must consider costs with no direct relationship with physical flows typically included in LCI (Norris 2001; Rebitzer et al. 2003). Nevertheless, the importance of the inventory analysis in facilitating cost accounting must not be underestimated. Indeed, the inventory phase of an LCA provides the quantities of physical flows through the life cycle, and the associated costs can be obtained by multiplying these quantities by the respective company costs or market prices. The costing aspects of table 4.5 displayed in italics can be derived, at least in part, from the inventory. Additional aspects mentioned above, such as labor costs, etc., will have to be gathered, but if this is carried out concurrently to the inventory, minimal additional effort will be required.

Table 4.5. Cost categories in LCC identified in the inventory phase of an LCA (in italics).

Life cycle stage	Costs for product manufacturer	Costs for product user
R&D	Market research, development costs	
Production	<i>Materials, energy, machines, plants, labor, waste management, emission controls, transports</i>	
Use	Maintenance/repair (warranty), liability, infrastructure	<i>Transports, storage, materials, energy, maintenance/repair (warranty), infrastructure</i>
End of life		<i>Waste collection, disassembly/recycling/disposal</i>

Source: Rebitzer et al. 2003.

### 4.5.3. Review of integration strategies

Different strategies and methods have been developed in order to cross the two dimensions, namely environmental and economic performance. In this section several approaches are described, in terms of how the tools are applied and in terms of how environmental and economic results are integrated for decision making.

#### 4.5.3.1. Simultaneous application

The easiest way of combining LCA and LCC is to perform both assessments simultaneously and to present at the end the results separately. Several examples of this strategy can be found in different sectors: urban wastewater treatment (Rebitzer et al. 2003), sulphur emissions abatement in a power plant (Sampattagul et al. 2004), and housing (Keoleian et al. 2000). In all of these examples, the life cycle tools are used together in a consistent way, and with regard to the results, it is decided not to mix environmental and economic data, but to keep them as different criteria. In addition of being the simplest procedure, it is also the most transparent, as it is not attempted to reduce the two dimensions to a single score.

#### 4.5.3.2. The BEES method

BEES (Building for Environmental and Economic Sustainability) is a software tool developed in the US by the NIST with support from the USEPA<sup>1</sup>. This tool is used to assess the environmental impacts and the total costs that occur during the entire life cycle of a specific building product (Lipiatt and Boyles 2001). Environmental performance is measured by means of standardized LCA, and economic performance is measured by means of ASTM-standardized LCC. The software contains its own LCI and cost databases for building products. In addition to the separate LCA and LCC results, the tool allows to combine these in a global index, based on the relative importance the user attributes to each criteria, ranging from 0% to 100%. Thus, BEES facilitates decision making by allowing the user to reduce the results to a single score or eco-efficiency index.

#### 4.5.3.3. The BASF Ecoefficiency method

The Eco-efficiency analysis developed by BASF (Saling et al. 2002; Tiemi and Anderi 2005) is an approach to quantify the sustainability of products and processes. The method has been applied in the chemical industry and also in other sectors (Shonnard et al. 2003; Jenseit et al. 2003). The three pillars on which the Eco-efficiency analysis is based are: LCA, LCC, and a simplified Risk Assessment. The LCA is performed in accordance with the ISO standard, while the cost assessment includes internal present and future costs, totaled over the life cycle. It is not clear, however, if future costs are discounted or not. The Risk Assessment is based on a simple evaluation of hazard associated to the chemicals involved in the life cycle, and on a simple evaluation of accident risks, based on statistical data. The alternatives under study are compared in terms of customer benefit, an equivalent concept to the functional unit used in LCA. After carrying out the independent evaluations, the life cycle costs are normalized with regard to the country's industrial sales, while the LCA results and Risk assessment results are normalized and weighed together, in order to obtain an environmental impact score.

---

<sup>1</sup> Currently BEES 3.0 can be downloaded from [www.bfrl.nist.gov/oea/software/bees.html](http://www.bfrl.nist.gov/oea/software/bees.html)

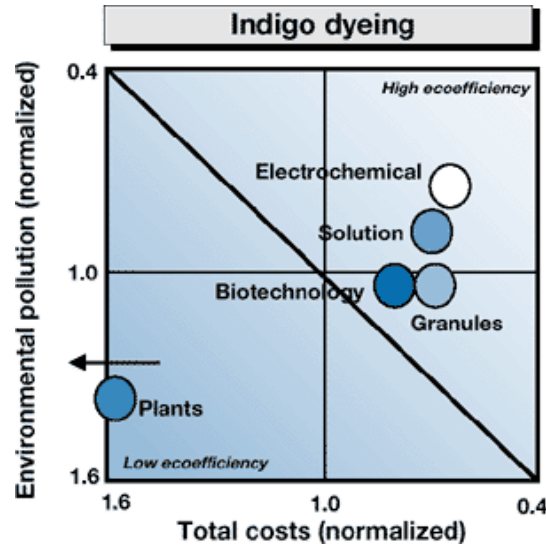

Figure 4.6. Eco-efficiency portfolio for alternative indigo production and dyeing systems. Source: BASF (2000).

The final step of the method is to create an eco-efficiency portfolio (figure 4.6), illustrating the performance of the alternatives: the closer an alternative gets to the upper-right corner of the portfolio, the higher its eco-efficiency becomes; as the position moves in the opposite direction, eco-efficiency decreases. This approach assumes that environmental performance is as important as economic performance, thus an economically less advantageous system can compensate for this disadvantage with a better environmental performance. This is shown in the portfolio by the diagonal line: alternatives moving through this line do not represent a net eco-efficiency gain. In figure 4.6, for example, the most eco-efficient alternative is synthetic indigo with electrochemical dyeing, while the least eco-efficient is using plant-derived indigo powder in the traditional dyeing process.

#### 4.5.3.4. The Econo-environmental return

Rather than a method for application and integration of LCC and LCA, the Econo-environmental return (EER) (Bage and Samson 2003) is an index for comparing two or more alternatives on both environmental impacts and economic aspects at the same time. The index can be built by using LCA and LCC results, but not necessarily. Nevertheless, whichever the tools used, the evaluation must be carried out coherently for all alternatives, namely using the same functional unit, the same discount rate, etc. As the concept of eco-efficiency by BASF, the EER is built on the idea that the same importance must be attributed to environmental and economic aspects.

Consider two goods, A and B; the EER of good B relative to good A is calculated with equation 4.2:

$$EER_{B/A} = \left( \frac{EnvI_A^- \cdot EconI_A^-}{EnvI_B^- \cdot EconI_B^-} \right) - 1 \quad (4.2)$$

Where:

$EnvI_A^-$  is the environmental impact of alternative A,  
 $EnvI_B^-$  is the environmental impact of alternative B,  
 $EconI_A^-$  is the economic cost of alternative A, and  
 $EconI_B^-$  is the economic cost of alternative B.

Environmental impacts and costs can be expressed in any units, for example ecopoints and €, respectively. If  $EER_{B/A}$  is positive, then good B is preferable to good A. If  $EER_{B/A}$  equals zero, both goods are equivalent. If  $EER_{B/A}$  is negative, then good A is preferable to good B.

#### 4.5.3.5. Monetary valuation of LCA results

It has also been suggested to convert the environmental impacts quantified by means of LCA to monetary units; once this is done, these external costs can be added to the internal costs quantified by means of LCC, obtaining a total cost of the product or process. In the previous methods, LCA and LCC have been presented as parallel tools, while here they become consecutive tools (Carlsson 2005). This approach may be seen as sort of cost-benefit analysis using life cycle concepts, since all costs and benefits through the life cycle are expressed in a common monetary unit. It has to be borne in mind, however, that this procedure is not supported by the LCC definition by SETAC (section 4.4.2).

Carlsson (2005) has applied this approach to compare alternatives for municipal waste management. The procedure involves applying conventional LCC and LCA with the difference that the LCA results are converted to monetary units using weighting methods like EPS (Steen 1999), Ecotax (Eldh 2003) or ECON (Vennemo 1995), which value the external cost of environmental impacts by means of willingness-to-pay, or tax and fee systems. Clearly, reducing life cycle impacts and costs to money value is an advantage for decision making, since money is an unidimensional measure that is easily understood and comparable. However, apart from the question of whether or not external costs can be properly expressed in monetary units, Carlsson (2005) also identifies several methodological problems, some of them already discussed in previous sections:

- If an environmental issue is already internalized by a tax, and the latter is included in the LCC, the valuation of the same impact in the “monetary LCA” would imply double counting.
- Double counting can also occur with environmental valuation of natural resources due to scarcity value, as market prices in theory already mirror scarcity.
- None of the weighting methods mentioned use any kind of discounting of future emissions, involving an inconsistency with conventional LCC.

#### 4.5.3.6. Total Cost Assessment by CWRT

Yet another approach allowing the monetization of external life cycle costs is the Total Cost Assessment (TCA) method, developed By the AIChE's CWRT in collaboration with ten major industrial companies (CWRT 1999). In addition to a detailed methodological framework, a software tool has also been developed, TCAce<sup>®</sup> (Norris 2001). The TCA methodology consists of 7 steps:

- Goal definition and scoping,
- Streamlining of the analysis,
- Identification of potential risks,
- Conduct financial inventory,
- Conduct impact assessment,
- Documentation of results, and
- Feedback to company's main decision loop.

TCA has been designed mainly for business decision making, and is based on the identification and quantification of 5 cost types (table 4.6). Cost types 1 to 4 are internal costs borne by the company, although conventional LCC practice usually only includes types 1 and (sometimes) type 2. The TCA methodology is designed to broaden the scope and include contingent and intangible costs. Finally, type 5 costs correspond to externalities, which are derived from LCI data associated to the process or product under study. Pollutant emissions to air, water and land present in the LCI are assigned monetary values and thus converted to costs. However, if included in the analysis, type 5 costs must be kept separate from internal costs (types 1 to 4), due to the fact that external costs are borne by society, not the company, and also because they should be discounted using a social rate, instead of the company's rate; it is up to the user to determine how to use type 5 costs in decision making.

Table 4.6. Cost types in the AIChE/CWRT total cost assessment method and TCAce tool.

Cost type	Description
Type 1: Direct	Direct costs of capital investment, labor, raw material, and waste disposal. May include both recurring and nonrecurring costs. Includes both capital and operations and maintenance (O&M) costs.
Type 2: Indirect	Indirect costs not allocated to the product or process (overhead). May include both recurring and nonrecurring costs. Includes both capital and O&M costs.
Type 3: Contingent	Contingent costs such as fines and penalties, costs of forced cleanup, personal injury liabilities, and property damage liabilities.
Type 4: Intangible	Difficult to measure costs, including consumer acceptance, customer loyalty, worker morale, union relations, worker wellness, corporate image, and community relations.
Type 5: External	Costs borne by parties other than the company (e.g., society).

Source: Norris 2001.

Although TCA claims to be life-cycle based, it seems to be mainly concerned with quantification of actual and potential costs directly affecting the firm, not the entire product or process chain. Rather than a simultaneous application of LCC and LCA, TCA can be considered as a detailed environmental cost accounting method allowing to integrate, if desired, life cycle impacts in monetary terms.



## 4.6. Previous Environmental Assessments of AOPs for Wastewater Treatment

There is extensive literature on the application of LCA to wastewater treatment systems. Most of the studies deal with urban wastewater, focusing on the performance of conventional Municipal Wastewater Treatment Plants (MWWTP) applying primary, secondary, and sometimes tertiary treatment (Emmerson et al. 1995; Roeleveld et al. 1997; Tillman et al. 1998; Dennison et al. 1998; Lundin et al. 2000; Gaterell and Lester 2000; Vidal et al. 2002; Strömberg and Paulsen 2002; Hospido et al. 2004). If the search is restricted to industrial wastewater, the literature is much more scarce (Jorgensen et al. 2004; Pillay et al. 2002). As far as the application to AOPs for wastewater treatment is concerned, the number of published studies is also very low. In fact, two of the few papers published on the issue (Muñoz et al. 2005b; Muñoz et al. 2006) belong to the work presented in chapter 5 of this thesis, and for this reason they are not discussed here. In this section only the remaining references are discussed.

### 4.6.1. LCA studies

Nijdam and coworkers (1999) applied LCA to compare two options of tertiary wastewater treatment: granular activated carbon (GAC) adsorption and ozone in combination with UV light. These options were assessed in two different scenarios concerning the type of wastewater to treat: on the one hand, biologically pre-treated leachate from a German landfill, and on the other hand polluted groundwater containing hexachlorohexane and chlorobenzenes. The ozone/UV system included production of electricity and oxygen, and transport of the latter to the plant. The GAC system included production of GAC from peat, reactivation of spent GAC, production of electricity consumed at the plant and transports. However, the data used for GAC production and reactivation is not shown nor discussed, with the exception of peat extraction, which is taken into account only qualitatively. Concerning the ozone/UV system, production of the UV lamps is excluded and in both systems capital goods are also excluded. The functional unit chosen in the study is to treat 1 m<sup>3</sup> of polluted water. The results of the study show that GAC involves a much lower environmental impact in all indicators and in both scenarios assessed. The worse results of ozone/UV are associated to the high energy consumption to produce ozone and to irradiate the wastewater, as well as to the production of oxygen.

### 4.6.2. Other environmental studies

No other LCA study has been found on AOPs, although some elementary environmental assessments have been carried out in order to demonstrate the advantages of solar-driven AOPs as compared to competing technologies. Klausner and coworkers (1992) simulated the energy requirements of GAC adsorption, air stripping and solar-driven heterogeneous photocatalysis to treat water polluted with TCE. The study was restricted to calculating theoretical energy requirements due to pumping and reactivation of spent GAC, depending on several plant design parameters. The study is not very conclusive; air stripping appears as the most energy-efficient option, but the authors admit that it is not fully comparable to GAC adsorption and photocatalysis, since TCE is transferred to the atmosphere, while the other techniques destroy the pollutant. This is a clear example of the potential benefits that would have been derived if LCA had been used in such a comparison, since comparability of the alternatives would have been determined in the goal and scope phase, through the definition of the function and functional unit. At this point, air stripping could have been simply excluded. If otherwise it would have been accepted as a comparable alternative, the LCI and LCIA phases would have allowed to take into account the transfer of pollutants to the atmosphere and their associated environmental impacts, which are absent in the GAC and photocatalytic alternatives.

In a similar study (Link and Turchi 1991), GAC adsorption, UV/hydrogen peroxide oxidation and solar-driven heterogeneous photocatalysis were compared on the basis of energy requirements and carbon dioxide emissions from electricity production due to pumping, spent GAC reactivation and operation of lamps. The data are obtained from a facility in northern California, treating groundwater containing mostly TCE. The results of the study show that the UV/hydrogen peroxide system involves the highest energy requirements as well as carbon dioxide emissions, while these environmental impacts are substantially lower for GAC and solar photocatalysis, being the latter the best option. In addition to the environmental assessment, economic cost is estimated as well for the three options, including capital costs, and operation/maintenance costs. Solar-driven heterogeneous photocatalysis appears as the cheapest option (\$3/kgal) as compared to UV/hydrogen peroxide (4\$/kgal) and GAC adsorption (\$5/kgal). This is the only attempt of including both the environmental and economic dimensions in a single study. However, while the economic assessment can be considered as an LCC which excludes the end-of-life costs, the environmental assessment is clearly insufficient as compared to a present-day LCA.

#### 4.6.3. Conclusions

As can be seen from this review, the literature on environmental performance of AOPs is manifestly limited, and even more when the aim is to include integrated environmental and economic performance. The only LCA found focused only on ozone, while the other two studies are not LCAs, but first attempts to quantitatively assess environmental issues associated to these technologies. As a consequence, there is a strong need to perform a complete LCA and LCC of different AOPs, since up to date such a study of these emergent technologies has not been carried out.

## References to Chapter 4

- Althaus H J, Chudacoff M, Hirschier R, Jungbluth N, Primas A, Osses M. 2004. *Life Cycle Inventories of Chemicals*. Final report ecoinvent 2000 No. 8, Swiss Centre for Life Cycle Inventories, Duebendorf, Switzerland.
- American Society for Testing and Materials (ASTM). 1999. *Practice E917-99: Standard practice for measuring life-cycle costs of buildings and buildings systems*. West Conshohocken, Pennsylvania.
- Anastas P T, Lankey R L. 2000. *Life cycle assessment and green chemistry: the ying and yang of industrial ecology*. *Green Chemistry*, 2000, 2, pp. 289-295.
- Assies J A. 1992. *State of art*. In: Report of Workshop on Life-Cycle Assessment organised by SETAC-Europe, December 2-3, 1991, Leiden, The Netherlands, pp. 1-20.
- Azapagic A, Clift R. 1999. *Life Cycle Assessment and multiobjective optimisation*. *Journal of Cleaner Production*, 7, pp. 135-143.
- Azapagic A. 2002. *Life-cycle Assessment: a tool for identification of more sustainable products and processes*. In: Clark J, Macquarrie D. *Handbook of green chemistry and technology*. Blackwell Science. Chapter 5, pp. 62-85.
- Bage G, Samson R. 2003. *The Econo-Environmental Return (EER). A link between environmental impacts and economic aspects in a life cycle thinking perspective*. *International Journal of Life Cycle Assessment*, 8 (4), pp. 246-251.
- BASF. 2000. *The BASF Eco-efficiency Analysis*. Online document ([www.basf.de/basf/img/position/effizienz\\_e.pdf](http://www.basf.de/basf/img/position/effizienz_e.pdf))
- Burgess A A, Brennan D J. 2001. *Application of life cycle assessment to chemical processes*. *Chemical Engineering Science*, 56, pp. 2589-2604.
- Carlsson M. 2005. *Economic assessment of municipal waste management systems—case studies using a combination of life cycle assessment (LCA) and life cycle costing (LCC)*. *Journal of Cleaner Production*, 13 (3), pp. 253-263.
- Clift R. 2005. *Integrating LCA and process flowsheeting to analyse industrial ecosystems*. Presented at the Seminar on Energy and Industrial Ecology. Norwegian University of Science and Technology, 11 may, Trondheim.
- Consoli F, Allen D, Boustead I, de Oude N, Fava J, Franklin W, Quay B, Parrish R, Perriman R, Postlethwaite D, Seguin J, Vigon B. 1993. *Guidelines for Life-Cycle Assessment: A Code of Practice*. Society of Environmental Toxicology and Chemistry. Brussels, Belgium.
- Costanza R. (Ed.). 1991. *Ecological Economics: the science and management of Sustainability*. Columbia University press, New York.
- CWRT. 1999. *Total Cost Assessment Methodology*. ISBN # 0-8169-0807-9. American Institute of Chemical Engineers. New York.
- Dennison F J, Azapagic A, Clift R, Colbourne J S. 1998. *Assessing management options for wastewater treatment works in the context of Life Cycle Assessment*. *Water Science and Technology*, 38 (11), pp. 23-30.
- Domènech X, Ayllón J A, Peral J, Rieradevall J. 2002. *How green is a chemical reaction? application of LCA to Green Chemistry*. *Environmental Science and Technology*, 36, 5517-5520.
- Domènech X. 2005. *Química Verde*. Rubes Editorial, Barcelona.
- EIPPCB. 2005. *Integrated pollution prevention and control. Reference document on economics and cross-media effects*. European Commission European IPPC Bureau, Seville, Spain. <http://eippcb.jrc.es>
- Eldh P. 2003. *Ecotax02 – An update of a Life Cycle Assessment weighting method with a case study on waste management*. Master of Science Thesis. TRITA-KET-IM 2003:12. Dept. of Chemical Engineering and Technology, Royal Institute of Technology, Stockholm.
- Emmerson R H C, Morse G K, Lester J N, Edge D R. 1995. *Life-cycle analysis of small scale sewage-treatment processes*. *Journal of the Chartered Institution of Water and Environmental Management*, 9 (3), pp. 317-325.

- EU. 1996. *Council Directive 96/61/EC of 24 September 1996 concerning integrated pollution prevention and control*. Official Journal L 257, 10/10/1996. pp. 26–40.
- Fava J A, Page A. 1992. *Application of product life cycle assessment to product stewardship and pollution prevention programs*. *Water Science and Technology*, 26 (1-2), pp. 275-287.
- Frischknecht R, Althaus H J, Doka G, Dones R, Heck T, Hellweg S, Hirschier R, Jungbluth N, Nemecek T, Rebitzer G, Spielmann M. 2004. *Overview and Methodology*. Final report ecoinvent 2000 No. 1, Swiss Centre for Life Cycle Inventories, Duebendorf, Switzerland. [www.ecoinvent.ch](http://www.ecoinvent.ch)
- Fullana P, Puig R. 1997. *Análisis del ciclo de vida*. Ed. Rubes, Barcelona.
- Fuller S K, Petersen S R. 1996. *Life-Cycle Costing Manual for the Federal Energy Management Program*. National Institute of Standards and Technology, Handbook 135. Prepared for U.S. Department of Energy. Washington DC. Available at: [www.eere.energy.gov/femp/program/lifecycle.cfm](http://www.eere.energy.gov/femp/program/lifecycle.cfm)
- Gaterell M R, Lester J N. 2000. *Establishing the true costs and benefits of environmental protection and enhancement in the aquatic environment*. *The Science of the Total Environment*, 249, pp. 25-37.
- Geisler G, Hofstetter T B, Hungerbühler K. 2004. *Production of Fine and Speciality Chemicals: Procedure for the estimation of LCIs*. *International Journal of Life Cycle Assessment*, 9 (2), pp. 101-113.
- Graedel T. 1996. *Weighted matrices as product Life Cycle Assessment Tools*. *International Journal of Life Cycle Assessment*, 1 (1), pp. 85-89.
- Graedel T. 1998. *Industrial Ecology and the automobile*. New Jersey. Prentice-Hall Inc.
- Graedel T. 1999. *Green Chemistry in an industrial ecology context*. *Green Chemistry*, 1999, 1 (5), pp. G126-G128.
- Guinée J B, Gorree M, Heijungs R, Huppes G, Kleijn R, Udo de Haes H A, Van der Voet E, Wrisberg M N. 2002. *Life Cycle Assessment. An operational guide to ISO standards*. Volume 1, 2, 3. Centre of Environmental Science, Leiden University (CML), The Netherlands.
- Heinze E, Weirich D, Brogli F, Hoffmann V H, Koller G, Verduyn M A, Hungerbühler K. 1998. *Ecological and economic objective functions for screening in integrated development of fine chemical processes. 1. Flexible and expandable framework using indices*. *Industrial & Engineering Chemistry Research*, 37, pp. 3395-3407.
- Hellweg S, Hofstetter T B, Hungerbühler K. 2003. *Discounting and the environment. Should current impacts be weighted differently than impacts harming future generations?*. *International Journal of Life Cycle Assessment*, 8 (1), pp. 8-18.
- Hellweg S, Fischer U, Scheringer M, Hungerbühler K. 2004. *Environmental assessment of chemicals: methods and application to a case study of organic solvents*. *Green Chemistry*, 2004, 6, pp. 418-427.
- Hochschorner E, Finnveden G. 2003. *Evaluation of two simplified Life Cycle Assessment methods*. *International Journal of Life Cycle Assessment*, 8 (3), pp. 119-128.
- Hoffmann V H, Hungerbühler K, Mc Rae G J. 2001. *Multiobjective screening and evaluation of chemical process technologies*. *Industrial & Engineering Chemistry Research*, 40, pp. 2513-4524.
- Hospido A, Moreira M T, Fernández-Couto M, Feijoo G. 2004. *Environmental performance of a municipal wastewater treatment plant*. *International Journal of Life Cycle Assessment*, 10 (5), pp. 336-345.
- Hugo A, Ciumei C, Buxton A, Pistikopoulos, E F. 2004. *Environmental impact minimization through material substitution: a multi-objective optimization approach*. *Green Chemistry*, 6, pp. 407-417.
- Huijbregts M A J, Guinée J B, Reijnders L. 2001. *Priority assessment of toxic substances in life cycle assessment. Part III: Export of potential impact over time and space*. *Chemosphere*, 44 (1), pp. 59-65.
- Hunkeler D, Rebitzer G. 2005. *The future of Life Cycle Assessment*. *International Journal of Life Cycle Assessment*, 10 (5), pp. 305-308.
- Hunt R G, Franklin W E. 1996. *LCA – How it came about – Personal reflections on the origin and the development of LCA in the USA*. *International Journal of Life Cycle Assessment*, 1 (1) pp. 4-7.
- Hunt R G, Boguski T, Weitz K, Sharma A. 1998. *Case studies examining streamlining techniques*. *International Journal of Life Cycle Assessment*, 3 (1) pp. 36-42.

- Huppes G. 1996. *LCA yesterday, today and tomorrow*. Centre of Environmental Science (CML). Leiden University, The Netherlands.
- ISO. 2003. *ISO/TR 14047 Environmental management – Life Cycle Impact Assessment – Examples of application of ISO 14042*. Geneva, Switzerland.
- ISO. 1997. *ISO 14040: Environmental management – Life cycle assessment – Principles and Framework*. Geneva, Switzerland.
- ISO. 1998. *ISO 14041: Environmental management – Life cycle assessment – Goal and Scope Definition and Inventory Analysis*. Geneva, Switzerland.
- ISO. 1999. *ISO 14042: Environmental management – Life cycle assessment – Life Cycle Impact Assessment*. Geneva, Switzerland.
- ISO. 2000. *ISO 14043: Environmental management – Life cycle assessment – Life Cycle Impact Interpretation*. Geneva, Switzerland.
- ISO. 2000. *ISO/TR 14049 Environmental management – Life Cycle Assessment – Examples of application of ISO 14041 to goal and scope definition and inventory analysis*. Geneva, Switzerland.
- Jenseit W, Stahl H, Wollny V, Wittlinger R. 2003. *Recovery Options for Plastic Parts from End-of-Life Vehicles: an Eco-Efficiency Assessment*. Prepared by Öko-Institut e.V. for APME. Darmstadt, Deutschland.
- Jiménez-González, C, Kim S, Overcash M R. 2000. *Methodology for developing gate-to-gate life cycle inventory information*. International Journal of Life Cycle Assessment, 5 (3), pp. 153-159.
- Jorgensen K R, Villanueva A, Wenzel H. 2004. *Use of life cycle assessment as decision-support tool for water reuse and handling of residues at a Danish industrial laundry*. Waste Management & Research, 22 (5), pp. 334-345.
- Keoleian G A, Blanchard S, Reppe P. 2000. *Life-cycle energy, costs, and strategies for improving a single-family house*. Journal of Industrial Ecology, 4 (2), pp. 135-156.
- Klausner J F, Goswami Y D, Wyness P R. 1992. *Energy consumption of wastewater treatment technologies*. Proceedings of the ASME International Solar Energy Conference, Vol. 1, pp. 29-36.
- Klöpffer W. *Life-Cycle based methods for sustainable product development*. International Journal of Life Cycle Assessment, 8 (3), pp. 157-159.
- Kniel G E, Delmarco K, Petrice J G. 1996. *Life Cycle Assessment applied to process design: environmental and economic analysis and optimisation of a nitric acid plant*. Environmental Progress, 15 (4), pp. 221-228.
- Lancaster M. 2002. *Green Chemistry An introductory Text*. RSC Paperbacks, UK.
- Lankey R L, Anastas P T. 2002. *Life-cycle approaches for assessing Green Chemistry technologies*. Industrial & Engineering Chemistry Research, 41, pp. 4498-4502.
- Link H, Turchi C. 1991. *Cost and performance projections for solar water detoxification systems*. Prepared for American Society of Mechanical Engineers (ASME), International Solar Energy Meeting, March 17–22, Reno, Nevada.
- Lipiatt B C, Boyles A S. 2001. *Using BEES to select cost-effective green products*. International Journal of Life Cycle Assessment, 6 (2), pp. 76-80.
- Lundin M, Bengtsson M, Molander S. 2000. *Life Cycle Assessment of wastewater systems: influence of system boundaries and scale on calculated environmental loads*. Environmental Science and Technology, 34, pp. 180-186.
- Marquevich M, Sonneman G W, Castells F, Montané D. 2002. *Life cycle inventory of hydrogen production by the steam-reforming process: comparison between vegetable oils and fossil fuels as feedstock*. Green Chemistry, 4, pp. 414-423.
- Milà LI. 2003. *Contributions to LCA methodology for agricultural systems. Site-dependency and soil degradation impact assessment*. PhD Thesis, Universitat Autònoma de Barcelona.
- Muñoz I, Rieradevall J, Domènech X. 2005a. *Definición de la unidad funcional e implicaciones en el ACV*. In: Clemente G, Sanjuán N, Vivancos J L. (Eds.). *Análisis de Ciclo de Vida: aspectos metodológicos y casos prácticos*. Ed. Universidad Politécnica de Valencia.

- Muñoz I, Rieradevall J, Torrades F, Peral J, Domènech X. 2005b. *Environmental assessment of different solar driven advanced oxidation processes*. Solar Energy, 79, pp. 369-375.
- Muñoz I, Rieradevall J, Torrades F, Peral J, Domènech X. 2006. *Environmental assessment of different advanced oxidation processes applied to a bleaching kraft mill effluent*. Chemosphere, 62, pp. 9-16.
- Nijdam D, Blom J, Boere J A. 1999. *Environmental Life Cycle Assessment (LCA) of two advanced wastewater treatment techniques*. Studies in Surface Science and Catalysis 120 B, 763-775.
- Norris G. 2001. *Integrating economic analysis into LCA*. Environmental Quality Management, spring 2001, pp. 59-64.
- O'Brien M, Doig A, Clift R. (1996). *Social and environmental Life Cycle Assessment (SECLA)*. International Journal of Life Cycle Assessment, 1 (4), pp. 231-237.
- Pasqual J. 1998. *La rentabilidad de un proyecto público*. Col·lecció Materials, nº 7. Servei de publicacions, Universitat Autònoma de Barcelona.
- Pearce D W. 1971. *Cost-benefit analysis*. MacMillan Studies in Economics, London.
- Pillay S D, Friedrich E, Buckley C A. 2002. *Life Cycle Assessment of an industrial water recycling plant*. Water Science and Technology, 46 (9), pp. 55-62.
- Pommer K, Bech, Wenzel H, Caspersen N, Olsen S I. 2001. *Handbook on environmental assessment of products*. Environmental Project nº 813. Danish Environmental Protection Agency, Danish Ministry of the Environment.
- Rabl A. 1996. *Discounting long-term costs: what would future generations prefer us to do?*. Ecological Economics, 17, pp. 137-145.
- Rebitzer G, Hunkeler D, Jolliet O. 2003. *LCC – the economic pillar of sustainability: methodology and application to wastewater treatment*. Environmental Progress, 22 (4), pp. 241-249.
- Rebitzer G, Hunkeler D. 2003. *Life Cycle Costing in LCM: ambitions, opportunities and limitations. Discussing a framework*. International Journal of Life Cycle Assessment, 8 (5), pp. 253-256.
- Rebitzer G, Seuring S. 2003. *Methodology and application of Life Cycle Costing*. International Journal of Life Cycle Assessment, 8 (2), pp. 110-111.
- Roeleveld P J, Klapwijk A, Eggels P G, Rulkens W H, van Starckenburg W. 1997. *Sustainability of municipal wastewater treatment*. Water Science and Technology, 35 (10), pp. 221-228.
- Saling P, Kicherer A, Dittrich-Krämer B, Wittlinger R, Zombik W, Schmidt I, Schrott W, Schmidt S. 2002. *Eco-efficiency by BASF: the method*. International Journal of Life Cycle Assessment, 7 (4), pp. 203-218.
- Sampattagul S, Kato S, Kiatsiroat T, Widiyanto A. 2004. *Life cycle considerations of the flue gas desulphurization system at a lignite-fired power plant in Thailand*. International Journal of Life Cycle Assessment, 9 (6), pp. 387-393.
- Schmidt W P. 2003. *Life Cycle Costing as part of Design for Environment. Environmental business cases*. International Journal of Life Cycle Assessment, 8 (3), pp. 167-174.
- Shapiro K. 2001. *Incorporating costs in LCA*. International Journal of Life Cycle Assessment, 6 (2), pp. 121-123.
- Sherif Y S, Kolarik W J. 1981. *Life Cycle Costing – Concept and practice*. OMEGA – The International Journal of Management Science, 9 (3), pp. 287-296.
- Shonnard, D R, Kicherer A, Saling P. 2003. *Industrial applications using BASF Eco-Efficiency analysis: perspectives on Green Engineering principles*. Environmental Science and Technology, 37 (23), pp. 5340-5348.
- Sikdar S. 2003. *Journey towards sustainable development: a role for chemical engineers*. Environmental Progress, 22 (4), pp. 227-232.
- Sonneman G, Castells F, Schuhmacher M. 2004. *Integrated Life-Cycle and Risk Assessment for Industrial Processes*. Lewis Publishers, Florida, USA.
- Steen B. 1999. *A systematic approach to environmental strategies in product development (EPS). Version 2000 – Models and data from the default model*. CPM report 1999:4. CTH, Göteborg.

- Strömberg L, Paulsen J. 2002. *LCA application to russian conditions*. International Journal of Life Cycle Assessment, 7 (6), pp. 349-357.
- Tiemi M T, Anderi G. 2005. *Eco-Efficiency analysis by BASF: case study in Brazil*. LCM 2005 – Innovation by Life Cycle Management. International Conference. Book of abstracts, vol. 1. pp. 145-149.
- Tietenberg T. 1992. *Environmental and natural resource economics*. Third ed. Harper Collins Publishers Inc.
- Tillmann A M, Svingby M, Lundström H. 1998. *Life Cycle Assessment of Municipal Waste Water Systems*. International Journal of Life Cycle Assessment, 3 (3), pp. 145-157.
- Tillman A M. 2000. *Significance of decision-making for LCA methodology*. Environmental Impact Assessment Review, 20, 1, pp. 113-123.
- Todd J A. 1995. *Streamlining LCA concepts and thoughts*. In: Curran M A. Life Cycle Assessment. Ed. McGraw-Hill.
- Todd J A, Curran M A. 1999. *Streamlined Life Cycle Assessment: a final report from the SETAC North America Streamlined LCA workgroup*. Society for Environmental Toxicology and Chemistry (SETAC) and SETAC Foundation for Environmental Education.
- Udo de Haes, H A. 1993. *Applications of life cycle assessment: Expectations, drawbacks and perspectives*. Journal of Cleaner Production, 1 (3-4), pp. 131-137.
- UNEP/SETAC Life-Cycle Initiative. 2001. *Background paper of the UNEP/SETAC Life-Cycle Initiative*. UNEP, DTIE, Paris.
- USEPA. 1995. *An introduction to environmental accounting as a business management tool: key concepts and terms*. EPA 742-R-95-001, Washington DC.
- Vennemo H. 1995. *Miljøkostnader knyttet til ulike typer avfall*. ECON-rapport 338/95, Oslo: ECON, Senter for økonomisk analyse.
- Vidal N, Poch M, Martí E, Rodríguez-Roda I. 2002. *Evaluation of the environmental implications to include structural changes in a wastewater treatment plant*. Journal of Chemical Technology and Biotechnology, 77, pp. 1206-1211.
- Wenzel H, Hauschild M, Alting L. 1998. *Environmental Assessment of Products*. Vol. 1: Methodology, tools and case studies in product development. Chapman & Hall.
- Woodward D. 1997. *Life cycle costing – theory, information acquisition and application*. International Journal of Project Management, 15 (6), pp. 335-344.
- Yasui I. 2003. *Metrics for green and sustainable chemistry*. Green Chemistry, 5 (5), pp. G70-G73.





# CHAPTER 5.

## Streamlined Life Cycle and Cost Assessment of different Advanced Oxidation Processes for Wastewater Treatment

---

*"In theory, there is no difference between theory and practice. But, in practice, there is"*

*Jan L.A. van de Snepscheut*

### CONTENTS

5.1. Goal and Scope .....	97
5.1.1. Goal.....	97
5.1.2. Streamlining approach .....	97
5.1.3. Experimental data .....	98
5.1.3.1. Background .....	98
5.1.3.2. Methodology and results .....	98
5.1.4. AOPs included in the study .....	100
5.1.5. Function and Functional Unit.....	101
5.1.6. Electricity and solar scenarios .....	102
5.1.7. System Boundaries .....	102
5.1.7.1. Excluded processes .....	102
5.1.7.2. Included processes.....	103
5.1.8. Main hypothesis and limitations.....	104
5.1.8.1. DOC removal.....	104
5.1.8.2. Energy consumption.....	104
5.1.8.3. Chemicals consumption .....	104
5.1.8.4. Relationship between DOC removal, energy and chemicals consumed .....	105
5.1.8.5. Laboratory scale .....	105
5.1.9. Data sources and Quality .....	105
5.1.9.1. Inputs from technosphere.....	106
5.1.9.2. Environmental interventions related to inputs from technosphere .....	106
5.1.10. Allocation.....	107
5.1.11. Life Cycle Impact Assessment Methodology.....	107
5.1.11.1. Selection of impact categories, Classification and Characterisation.....	107
5.1.11.2. Normalisation and weighting .....	109
5.2. Inventory Analysis.....	110
5.2.1. Energy consumption.....	110
5.2.2. Chemicals consumption .....	110

5.2.3. Transport of chemicals .....	111
5.2.4. Summary tables .....	112
5.3. Life Cycle Impact Assessment .....	113
5.3.1. Baseline scenario .....	113
5.3.1.1. Contribution analysis .....	113
5.3.1.2. Comparative analysis .....	114
5.3.2. Solar scenario .....	115
5.3.2.1. Contribution analysis .....	115
5.3.2.2. Comparative analysis .....	116
5.3.2.3. Comparative analysis changing the functional unit.....	117
5.3.3. Electricity vs. solar energy.....	119
5.4. Cost Assessment .....	120
5.5. Integration of Environmental Impact and Cost .....	122
5.6. Conclusions and Recommendations .....	124
5.6.1. Main conclusions to the case study.....	124
5.6.1.1. Sub-systems.....	124
5.6.1.2. Scenarios .....	124
5.6.1.3. Treatments .....	125
5.6.1.4. Cost.....	125
5.6.1.5. Eco-efficiency .....	125
5.6.2. Further research needs .....	125
References to Chapter 5 .....	127
Appendix 5.1. Life Cycle Impact Assessment tables.....	129

As discussed in the previous chapters, this thesis sustains that LCA can be used to compare the environmental performance of chemical processes, in order to detect inefficiencies and opportunities for improvement, prior to the application of these processes to full scale. This chapter presents a case study in which the usefulness of the tool is assessed for this purpose, since it is applied at the most basic stage: the bench scale. In particular, the environmental performance of several AOPs tested in the laboratory with wastewaters coming from the pulp and paper industry is assessed. In addition of the environmental assessment, a simple cost assessment is performed as well, and both environmental and economic information is finally integrated.

## 5.1. Goal and Scope

According to the ISO standards, the goal and scope of the study must be clearly defined. This implies clearly stating the purpose and the intention for carrying out the LCA, as well as defining the system boundaries, the function of the system and functional unit, data requirements and main hypotheses, among others (ISO 1997, 1998). In addition, a specific section dealing with the streamlining approach used has been added.

### 5.1.1. Goal

The objective of this LCA case study is to compare different emerging technologies for advanced oxidation of contaminants present in industrial wastewaters from the kraft pulp industry. The assessed technologies are: heterogeneous photocatalysis, photo-Fenton, ozonation, and some combinations of these processes.

The general purpose of the case study is to contribute to the acceptance of LCA as a tool for “green” design of chemical products and processes, by showing the kind of information that the tool is able to provide in a practical application. Since part of the data used is derived from laboratory experiments, the extrapolation of the results to industrial scale is limited. However, this preliminary assessment may highlight the critical sources of environmental impact in the process life cycle, and the areas where improvements should be made when implementing these techniques to a larger scale.

### 5.1.2. Streamlining approach

According to Todd (1995), streamlining refers to approaches to conducting LCAs that reduce the scope, cost, and effort required for studies that use an LCA framework. Weitz et al. (1996) state that streamlining is not synonymous with screening. The present study, however, is a streamlined LCA used for purposes of screening, which means that we are not only concerned about obtaining concluding results, but also about determining whether an additional study is needed and where that study should focus.

The main characteristics making this study an streamlined LCA are the following:

- Some life cycle stages are left out, both upstream and downstream of the AOP. This aspect is discussed in section 5.1.7, dealing with system boundaries.
- Leaves out some impact categories. It has been preferred to limit the number of impact categories used, and therefore some of them, such as those relative to toxicity, have been deliberately excluded. The impact assessment methodology applied is described in section 5.1.11.
- Uses the most readily available data. This is considered the key streamlining method in this case study, referring to the fact that laboratory data is used as the basis for the inventory phase. Clearly, bench-scale data is the most readily available to assess a chemical process, and this constitutes an advantage, but also an inconvenient: the advantage is that potential impacts and possibilities for improvement can be detected at the beginning of the R&D stage; on the other hand, the main inconvenient is that data is incomplete (this links with the first point) and represents the furthest situation for the process from being optimized.

### 5.1.3. Experimental data

There has not been specific experimental work for the purpose of carrying out the present LCA. Instead, data from previous studies has been used. These studies are briefly introduced below.

#### 5.1.3.1. Background

The Chemistry Dept. of UAB and the Chemistry Engineering Dept. of UPC in Terrassa have been working together for several years in the field of wastewater treatment using AOPs (Pérez et al. 2001; Torrades et al. 2001). In March 2002 a paper was published (Pérez et al. 2002), in which several options for treatment of pulp bleaching effluents were assessed from an economic point of view, based on laboratory experiments.

The results of the study allowed the identification of cheap and expensive options for dissolved organic carbon (DOC) removal in pulp mill effluents, as well as synergies and cost decrease derived from the combination of treatments. However, the idea arose that a full assessment of these AOPs should include environmental information. As a consequence, the LCA methodology was chosen as the adequate tool to complement the previous economic assessment.

Being so, the mentioned work constitutes the starting point of the present LCA, and has been used as a main source of information. For this reason, a brief description of the experimental work is made below.

#### 5.1.3.2. Methodology and results

The effluents used in the study were the aqueous refuse of the chlorination step of the bleaching sequence<sup>2</sup> (D<sub>20</sub> C<sub>80</sub>) (E(O)) D<sub>1</sub> D<sub>2</sub> applied to Kraft paper pulp of Eucalyptus Globulus (90%) and Eucalyptus Grandis (10%), which was supplied by a north-east Spanish paper manufacturer. In order to reduce the level of organic contaminants, hydrolysis of the wastewaters with Ca(OH)<sub>2</sub> (pH 12, 1 h) followed by acidification (pH 3) was carried out. The composition of the wastewater entering the AOP after hydrolysis can be seen in Table 5.1.

Table 5.1. Initial characterisation of the bleaching kraft mill effluent after hydrolysis pretreatment.

Parameter	Value
pH	10.6
DOC (mg dm <sup>-3</sup> )	441
COD (mg dm <sup>-3</sup> O <sub>2</sub> )	1,384
Colour (mg dm <sup>-3</sup> Pt)	197

Source: Pérez et al. 2002.

Experiments were conducted in a thermostatic cylindrical Pyrex cell of 130 cm<sup>3</sup> capacity. The reaction mixture inside the cell, consisting of 100 cm<sup>3</sup> of organic effluent and the precise amount of reagents, was adjusted to pH 3 and continuously stirred with a magnetic bar. The temperature was kept at 25° C and the duration of the experiment was 180 minutes.

<sup>2</sup> This nomenclature refers to a conventional bleaching sequence with the following stages: chlorination using 80% chlorine gas and 20% chlorine dioxide, delignification using sodium hydroxide reinforced with subsequent addition of gaseous oxygen, and finally a two-stage bleaching using chlorine dioxide.

A 6 W Philips black-light fluorescent lamp was used as light source. The intensity of the incident light inside the photoreactor was  $1,38 \times 10^{-9}$  einstein/s.

Ozone was produced by a Sander Labor Ozonisor 301.7, fed with pure oxygen. The resulting ozone and oxygen mixture was immediately bubbled through the bleaching effluent. A working current of 1 A and a pressure of 0.5 bar were used. An ozonised oxygen flow rate of  $330 \text{ cm}^3 \text{ min}^{-1}$  ( $1.5 \text{ g O}_3 \text{ h}^{-1}$ ) was employed to ensure saturation of the system.

Several treatment options were assessed (Table 5.2, Figure 5.1), most of them being combinations of processes, and different reagent doses were tested. DOC was used as indicator of organic pollutant removal. In this Table, only the percentage of initial DOC removed is shown, as this is the main parameter of interest for the present LCA. Further information can be found in Pérez and coworkers (2002).

Table 5.2. List of AOP treatments included in the experiments and %DOC removal achieved after 180 minutes.

Treatment	% DOC removal
Heterogeneous photocatalysis	
1 g dm <sup>-3</sup> TiO <sub>2</sub>	8
2 g dm <sup>-3</sup> TiO <sub>2</sub>	15
6 g dm <sup>-3</sup> TiO <sub>2</sub>	16
Heterogeneous photocatalysis + H <sub>2</sub> O <sub>2</sub>	
10 ppm H <sub>2</sub> O <sub>2</sub>	14
100 ppm H <sub>2</sub> O <sub>2</sub>	17
500 ppm H <sub>2</sub> O <sub>2</sub>	21
Heterogeneous photocatalysis + H <sub>2</sub> O <sub>2</sub> + 20 ppm Fe <sup>2+</sup>	
10 ppm H <sub>2</sub> O <sub>2</sub>	18
100 ppm H <sub>2</sub> O <sub>2</sub>	20
500 ppm H <sub>2</sub> O <sub>2</sub>	30
Photo-fenton (20 ppm Fe <sup>2+</sup> + 500 ppm H <sub>2</sub> O <sub>2</sub> )	30
Ozonation	48
Ozonation + UVA	69
Ozonation / Photocatalysis (2 g dm <sup>-3</sup> TiO <sub>2</sub> ) *	38
Photocatalysis (2 g dm <sup>-3</sup> TiO <sub>2</sub> ) / Ozonation **	40

\* 1 h Ozone followed by 2 h Photocatalysis.

\*\* 1 h Photocatalysis followed by 2 h Ozone.

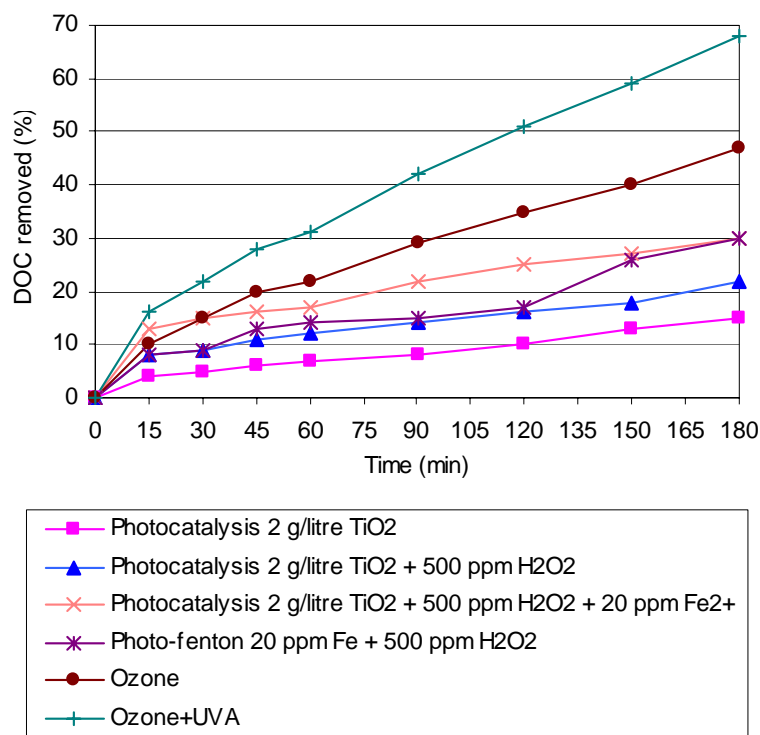

Figure 5.1. DOC removal vs. time in the experiments carried out with the bleaching kraft pulp mill wastewater (treatments not included in the LCA are omitted). Source: Pérez et al. (2002).

#### 5.1.4. AOPs included in the study

Not all treatments included in Pérez et al. (2002) have been considered in the LCA. Inclusion and exclusion criteria are presented and discussed below:

- In those techniques involving several H<sub>2</sub>O<sub>2</sub> doses, only the highest-dose case has been included, as the DOC removal achieved was higher.
- In photocatalysis using only TiO<sub>2</sub>, only the 2 g litre<sup>-1</sup> dose has been included, since this is the more cost-effective one. It is also the dose chosen in the other photocatalytic treatments.
- The combinations of ozone and photocatalysis have been excluded, because they are incompatible with the functional unit defined (see section 5.1.5). The reason is that these treatments are designed by setting a reaction time (1 hour) for one of the options, and leaving the remaining time (2 hours) for the other option. In this study time is not a fixed but a variable parameter for each treatment, and therefore the approach of setting a reaction time is not valid.

Consequently, 6 different treatments are included in the LCA. In Table 5.3, these treatments are summarized, along with the acronyms used from now on in the study.

Table 5.3. AOP treatments included in the LCA and acronyms assigned.

Treatment	Acronym
Heterogeneous photocatalysis (2 g dm <sup>-3</sup> TiO <sub>2</sub> )	Ti
Heterogeneous photocatalysis (2 g dm <sup>-3</sup> TiO <sub>2</sub> + 500 ppm H <sub>2</sub> O <sub>2</sub> )	Ti+H <sub>2</sub> O <sub>2</sub>
Heterogeneous photocatalysis and Photo-Fenton (2 g dm <sup>-3</sup> TiO <sub>2</sub> + 500 ppm H <sub>2</sub> O <sub>2</sub> + 20 ppm Fe)	Ti+Fe
Photo-Fenton (500 ppm H <sub>2</sub> O <sub>2</sub> + 20 ppm Fe)	Fe
Ozonation	O <sub>3</sub>
Ozonation + UVA	O <sub>3</sub> +UVA

### 5.1.5. Function and Functional Unit

Applied to full scale, the AOPs could be used as a pretreatment for wastewater. This would be useful to increase the biodegradability of the organic content in the water before entering a biological treatment stage. On the other hand, AOPs could also be placed after a biological treatment, for polishing, before discharging the water into the aquatic recipient. Each of these options can be identified as different functions (pre-treatment/post-treatment). However, since this case study is derived mainly from laboratory scale data, it is not possible to anticipate the configuration of a large scale application. As a consequence, the function of the system has been defined in a wide sense as:

*“Degradation of the persistent organic load in a kraft pulp mill effluent”.*

As it has been stated in section 5.1.2 the starting point for this LCA is the series of experiments carried out by Pérez and coworkers (2002). Therefore, the hypothesis, methodology as well as the results obtained in that work have to be taken into account in order to define the functional unit, that is, the unit of service whose environmental impacts will be assessed and which will be the basis to compare the different AOP technologies.

The main problem to define the functional unit with the available data arises from the different DOC removal efficiencies achieved by the different treatments included in the experiments. This implies that two possible ways of defining the functional unit can be discarded:

- A certain volume of wastewater entering the system: for instance, one cubic meter of wastewater. If different treatments achieve different DOC removal efficiencies, the purified water would have different quality in each case, thus leading to an incomparability in terms of the final product obtained.
- A certain quantity of pollutants destroyed: for instance one kg of DOC removed from the wastewater. In this case, as DOC removal efficiencies are different, the volume of water needed to achieve the same weight of pollutant removed would be different, thus leading to an incomparability in terms of volume of water treated and discharged. However, this approach was the one chosen by Pérez and coworkers (2002) to compare the economic costs of the AOPs.

The approach taken in the present study has been to define the functional unit on the basis of the same volume treated (1 m<sup>3</sup>) and the same amount of pollutants destroyed. In order to do this, a DOC removal threshold has to be defined that can be accomplished by all the AOPs compared. The minimum DOC removal achieved by all the treatments included, as can be seen in Table 5.1, is 15%, which corresponds to heterogeneous photocatalysis with a TiO<sub>2</sub> load of 2 g litre<sup>-1</sup>. Then, the functional unit is defined as:

*“Removal of 15% DOC from 1 m<sup>3</sup> kraft pulp mill wastewater as shown in Table 5.1”.*

It could be argued that 15% pollution removal is a very low threshold. In a full-scale plant, probably this wouldn't be enough to comply with legislation. However, it must be borne in mind that this is a preliminary assessment carried out from laboratory data. We are more concerned about making a fair comparison of AOPs than about the significance with regard to a hypothetical full-scale plant.

### 5.1.6. Electricity and solar scenarios

2 scenarios have been considered, affecting one of the key points in the study: the energy source used to run the AOPs. In the baseline scenario, it is considered that the energy source used to run either the UV-A lamp or the ozoniser is electricity from the grid. Although lamps and ozone are very effective, their use lead to an important economic and environmental problem, caused by the electrical demand. On the other hand, it has been introduced in chapter 3 that several AOPs can be performed under solar irradiation (figure 5.2), as the sun provides photons with the wavelength required for these processes (Malato et al. 2002). This is a promising aspect, since solar irradiation is a renewable and clean energy source. For this reason, in the second scenario it has been considered that sunlight is the only energy source to run the AOPs. This implies, however, that ozonation either in the dark or in the presence of light is excluded from this scenario, because ozone has to be produced using electricity.

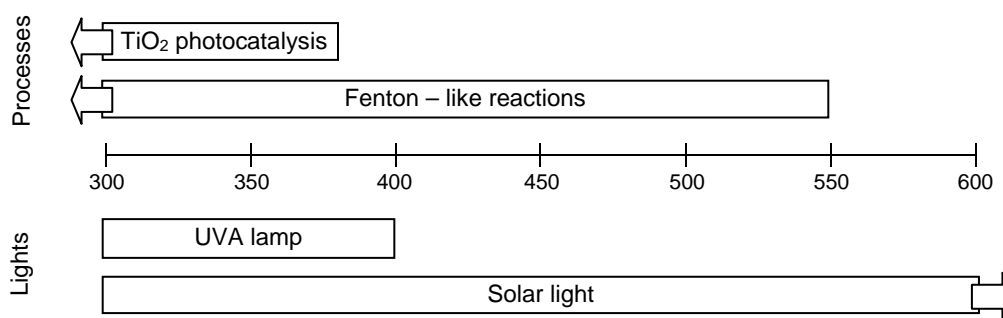

Figure 5.2. Wavelength intervals (nm) of different light sources used and the more appropriated intervals for some of the AOPs studied. Source: Pérez, 2001.

### 5.1.7. System Boundaries

In this section, all processes (both included and excluded) considered in the study are identified, as well as the reasons for their inclusion or exclusion. A general flow diagram showing the system boundaries is presented in Figure 5.3.

#### 5.1.7.1. Excluded processes

- Infrastructure and equipment for the different treatments are not included in the LCA. Infrastructure and equipment used in the laboratory is not considered to be representative.
- The biological stage, either before or after applying the AOPs, is excluded. As discussed in 5.1.2., with regard to biological treatment, AOPs can be used as a polishing stage, but also as a pre-treatment to increase the biodegradability of the wastewater. None of these configurations have been chosen as the most representative, and therefore biological treatment has been excluded. Furthermore, as the study focuses in AOPs, the functional unit has been defined in such a way that processes placed before and after the AOP can be excluded, as they are constant for all treatments.



- Physical-chemical pre-treatments and post-treatments are excluded, as they are also constant for all treatments. In particular, this applies for: alkaline hydrolysis (pre-treatment), acidification (pre-treatment), and neutralization (post-treatment).
- The environmental effects of the 85% DOC not removed ( $375 \text{ g m}^{-3}$ ) from the water are not taken into account, for several reasons:
  - Firstly, because in a full-scale application, all or almost all this recalcitrant DOC in the water would be removed, and consequently the environmental effects derived. In fact, setting as functional unit the removal of only 15% DOC is not really representative of a real plant, but it is the only way to fairly compare the different treatments with the available data.
  - Secondly, the same DOC content is present in the effluents of all treatments, so it is not a relevant aspect for the comparison, and can be excluded from the system.
  - Even if it was to be taken into account, there is no analytical data from the experiments concerning the content of single organohalogens or other toxic substances in the effluent, as the only monitoring parameter was DOC. This is a too general parameter to estimate the actual toxicity in water.
- $\text{CO}_2$  emissions produced by the mineralization of DOC ( $242 \text{ g CO}_2 \text{ m}^{-3}$  assuming 100% mineralization of the 15% DOC removed) are not taken into account. In the present application, DOC in the wastewater comes from a biogenic source (wood), therefore these emissions are compensated by the uptake of  $\text{CO}_2$  through photosynthesis (see table 5.5).

#### 5.1.7.2. Included processes

- Production of electricity consumed by the different AOPs. This sub-system comprises extraction of resources, transport, and electricity production, as well as production of the capital equipment required for these operations.
- Production of chemicals, namely the catalytic and stoichiometric reagents consumed by the AOPs. This sub-system comprises extraction of resources, transport, production of the different chemicals, transport to the wastewater treatment plant, and also production of capital goods.

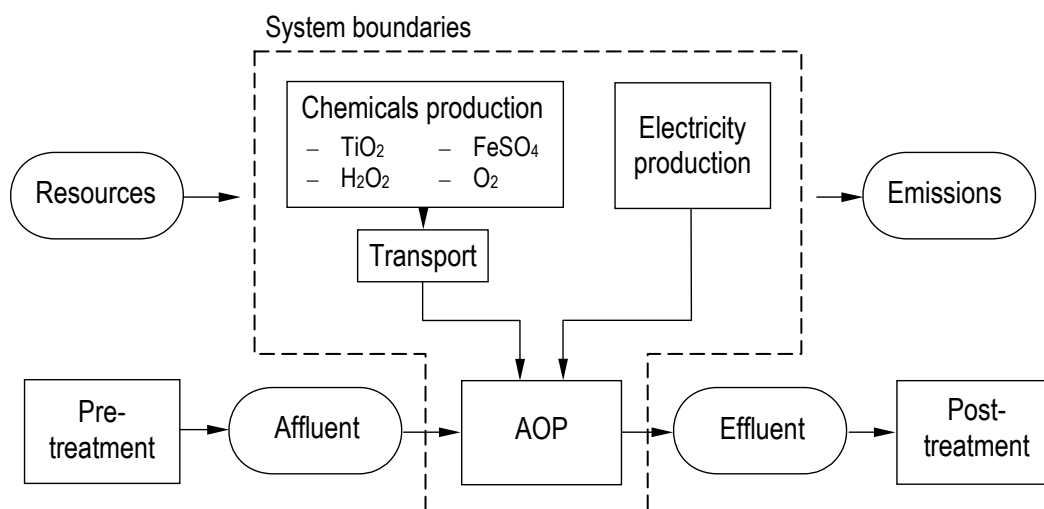

Figure 5.3. General flow diagram and system boundaries.

### 5.1.8. Main hypothesis and limitations

The main hypothesis considered and the limitations which have to be borne in mind are presented and briefly discussed below.

#### 5.1.8.1. DOC removal

- DOC is used as indicator of water pollution removal in all treatments. Ideally, toxicity should be the monitoring parameter, since toxic effects of persistent organic substances are the main reason to apply AOPs to wastewater. However, DOC seems to be a reasonable approximation, as it measures the organic content in solution. Furthermore, since all treatments are based in the generation of the same oxidative agent ( $\text{OH}\cdot$  radical), it is expectable that similar intermediates and final reaction products are produced.
- One of the key parameters in the study is the time needed by each treatment to reach 15% DOC removal. This is directly dependent on the reaction kinetics of each AOP. As can be seen in figure 5.1, all treatments follow a similar pattern: a higher DOC removal rate the first minutes, followed by a lower rate. There is, however, some experimental uncertainty, being the clearest example the photo-Fenton curve, which shows almost a plateau during the second hour of treatment. We have attributed this plateau not to the process but to the uncertainty already mentioned, thus suggesting that in this period of time the real slope is slightly higher. For this reason, in order to calculate the time needed by this treatment to reach 15% DOC removal, instead of the 90 minutes calculated from the graphic, a decrease to 75 minutes is assumed.

#### 5.1.8.2. Energy consumption

- The energy used to run either the UV-A lamp or the ozonisor has been assumed to be electricity on the medium voltage network (1 kV-24 kV), as this is the typical situation in industry (Frischknecht et al. 2004), and the technology mix is the average of the Union for the Coordination of Transmission of Electricity (UCTE), as modelled in the Ecoinvent database (see section 5.1.9.2). In the solar energy scenario, the AOPs are also able to reduce the organic content of the wastewater, but there is no electricity consumption.
- Energy needed for stirring and recirculation of the wastewater is excluded, as it can not be determined from the laboratory experiments.

#### 5.1.8.3. Chemicals consumption

- Hydrogen peroxide is assumed to be lost after 15% DOC removal. As reagent consumption is calculated from the dose applied (ppm), the problem is that the same consumption would be assigned either to a system removing 90% DOC or to another removing 15%, as it is the case in the present study.
- Catalyst recovery and reuse has been considered in all treatments involving  $\text{TiO}_2$ . This is justified by the fact that the catalyst dose is quite high in the case of  $\text{TiO}_2$  ( $2\text{g litre}^{-1}$ ) as compared to iron (II) (20 ppm). If  $\text{TiO}_2$  was not recovered this would have noticeable consequences in operation costs. Although the target for recovery is  $\text{TiO}_2$ , if iron is also present (case for Fe+Ti treatment), it is also recovered and reused, since the recovery process is valid for both: it consists of increasing the pH of the effluent by adding a base to attain the point of zero charge, allowing the catalyst to be settled; by this process more than 95% is recovered (Fernández-Ibáñez et al. 2003). In the inventory analysis it has been assumed that 100% of the catalyst is recovered, and that it is reused 10 times (Malato et al. 2000).
- In those treatments using only iron (II) as catalyst, there is no reuse of it. However it is not discharged to the aquatic recipient, as it precipitates in the form of hydroxides in the neutralization stage that takes place after the AOP. The

management of this chemical sludge, however, is excluded from the study, as well as that generated by spent TiO<sub>2</sub> in the corresponding treatments.

- All chemicals are assumed to be delivered to the wastewater treatment plant from a distance of 100 km, using a 16 ton truck.

#### 5.1.8.4. Relationship between DOC removal, energy and chemicals consumed

The following procedures have been used to calculate energy and chemicals consumption by the different AOPs:

- Electricity consumption for UV-A irradiation has been calculated on the basis of time required to reach 15% DOC reduction and the lamp power.
- Electricity consumption for O<sub>3</sub> production has been calculated on the basis of time required to reach 15% DOC reduction and the power of the ozoniser.
- O<sub>2</sub> consumption has been calculated on the basis of time required to reach 15% DOC reduction and the parameters of the ozoniser (O<sub>2</sub> flow).
- FeSO<sub>4</sub>, TiO<sub>2</sub>, and H<sub>2</sub>O<sub>2</sub> consumption is calculated from the dose applied in each treatment (in ppm or g litre<sup>-1</sup>).

As can be seen, energy and O<sub>2</sub> are time-dependent inputs, whereas the remaining chemical products are calculated on a volume basis: mg or g needed per litre wastewater. Assigning chemicals on the basis of volume of treated water has the problem that a system removing 90% of the DOC would be allocated the same amount of chemicals than another system treating the same amount of water but only removing 30% DOC, due to the fact that with the available data, it is not possible to calculate the consumption of iron or hydrogen peroxide associated to a given % DOC removal.

#### 5.1.8.5. Laboratory scale

- One of the most important limitations of this study arises from the laboratory scale at which the process parameters were measured, since laboratory reactors and equipment are not optimized. This can be seen in ozonation, one of the few AOPs commonly applied in water treatment, and from which full-scale data is available. An industrial ozoniser fed with oxygen uses about 10 kg oxygen per kg ozone produced (Perrot 2004), whereas from the experimental data in this study, a figure of 54 kg oxygen per kg ozone has been calculated. Bauer and Fallman (1997) admit that large scale plant figures would be less by a factor of ca.100, but also states that from a comparative point of view the data are valid.

#### 5.1.9. Data sources and Quality

Two levels of data sources can be distinguished in the case study: the first level corresponds to the data used to calculate the inputs from technosphere to the foreground system, and the second level is the data used to account for the environmental interventions related to those inputs from the background system.

### 5.1.9.1. Inputs from technosphere

The data used to calculate the inputs of chemicals and energy to the system under study is that included by Pérez and coworkers (2002), that is, laboratory-derived data.

### 5.1.9.2. Environmental interventions related to inputs from technosphere

Once the amount of chemicals and energy related to the functional unit are calculated, the inventory phase requires these inputs to be converted to inputs from nature (consumption of resources) and outputs to nature (emissions to the environment), derived from upstream operations.

In the present study, all the Life Cycle Inventory data has been extracted from the Ecoinvent database, version 1.1 (Frischknecht et al. 2004, 2003). This is a swiss database containing more than 2500 datasets of products and services, and can be considered as an update of the former BUWAL 250 and ETH databases (Habersatter, 1996; Frischknecht et al. 1994), which were the most popular among LCA practitioners during the last decade. The Ecoinvent database is mainly representative of the swiss situation in the year 2000. However, Switzerland's economy is closely linked to the surrounding countries, and therefore a lot of processes are also described for the average situation in Europe. In most cases, the average of currently used technologies is used, although in some cases the average of technologies on the market is used, or even near future best available technology. In the following table the Ecoinvent datasets used in the inventory are listed and briefly described; all of them are identified in the database as representative of Europe. Further information on how these datasets were modelled can be found in the corresponding Ecoinvent reports.

Table 5.4. Ecoinvent datasets used in the inventory phase.

Dataset	Reference	Description
Electricity, medium voltage, production UCTE, at grid	Dones et al. 2004	Mix of electricity production by the member countries of UCTE. Includes resources extraction, production of capital goods, electricity conversion by coal, lignite, oil, gas, nuclear, hydraulic, wind, biomass and photovoltaic. Includes transformation from high to medium voltage and the transmission of electricity at medium voltage.
Titanium dioxide, production mix, at plant	Althaus et al. 2004	Theoretical mix composed of 50% TiO <sub>2</sub> by the sulfate process and 50% by the chloride process. The inventory of both routes is based on confidential information supplied by industry sources. Includes all ancillary materials, precursors, transports and infrastructure.
Iron sulphate, at plant	Dones et al. 2004	FeSO <sub>4</sub> is a by-product of steel and iron manufacturing. This dataset only includes a rough estimation of the electricity use for purification of the by-product. No data for infrastructure and emissions.
Hydrogen peroxide, 50% in H <sub>2</sub> O, at plant	Althaus et al. 2004	This module contains material and energy input, production of waste and emissions for the production of hydrogen peroxide by the anthraquinone process. Transport and infrastructure have been estimated. The data is based on a study, performed by the Swiss Federal Laboratories for Materials Testing and Research (EMPA) and Boustead Consulting, commissioned by the European Chemical Industry Council (CEFIC).
Oxygen, liquid, at plant	Althaus et al. 2004	Cryogenic air separation. Data on energy demand and water resources based on several data sources of different plant size. Infrastructure demand estimated from data of small plants. This is a multi-output process; the environmental burdens are allocated to liquid nitrogen, liquid oxygen and liquid crude argon.
Transport, lorry 16t	Spielmann et al. 2004	Includes operation of the vehicle, production, maintenance and its disposal; also construction, maintenance and disposal of roads.

### 5.1.10. Allocation

Multiple processes are those which provide two or more functions (Huppes and Schneider, 1994). These processes constitute a problem if the system we are studying is only concerned with one of these functions. In such a case, a solution has to be found by either avoiding multiple processes by dividing the process into sub-processes or by enlarging the system under investigation so that the other functions are also involved, or by allocation, which means to divide the inputs and outputs among the functions.

In the present study no allocation problems have been identified. Nevertheless, the LCI datasets in the Ecoinvent database are built following certain allocation rules. General allocation procedures in Ecoinvent can be found in Frischknecht and coworkers (2004), and particular allocation rules for the datasets in table 5.4 are detailed in the corresponding references.

### 5.1.11. Life Cycle Impact Assessment Methodology

The aim of LCIA is to determine the potential environmental impacts of a product system by using category indicators derived from LCI results. The LCIA phase provides information for the interpretation phase (ISO 1999).

In the present study the following elements of LCIA, have been carried out:

- Selection of impact categories, impact indicators and models
- Assignment of LCI results (classification)
- Calculation of category indicator results (characterisation)

Therefore, LCIA is mainly based on the mandatory elements defined by ISO 14042. The optional elements normalisation and weighting have only been used where characterisation results yield an amount of information difficult to handle and to interpret.

#### 5.1.11.1. Selection of impact categories, Classification and Characterisation

Over the last decades a large number of impact category models have been developed (Udo de Haes et al. 1999). Current impact assessment methods usually include ten or more impact categories, such as the Ecoindicator 99 (Goedkoop and Spriensma, 2000), the CML 2000 method (Guinée et al. 2002) or the EDIP method (Hauschild and Wenzel, 1998). However, as this is a simplified LCA, it has been preferred to use a limited group of impact categories, and for this purpose the most widely used have been chosen. In table 5.5 these impact categories are listed and briefly described.

Table 5.5. Impact categories used in the study.

Impact category	Reference	Units	Description
Global Warming Potential (GWP)	Houghton et al. 1994, 1995	kg eq. CO <sub>2</sub>	Emissions as a result of human activities can affect the radiative forcing of the atmosphere, resulting in a rise in the earth's temperature. This, in turn, can cause adverse effects on ecosystem health, human health and material welfare. The indicator used is the Global Warming Potential (GWP). The GWP of a substance is the ratio between the contribution to the heat radiation absorption resulting from the instantaneous release of 1 kg of a greenhouse gas and an equal emission of CO <sub>2</sub> integrated over time. Biogenic CO <sub>2</sub> is not considered to be a contributor to the impact: If biogenic materials are grown on a sustainable basis (which has been assumed in the present study), then those emissions are considered simply to close the loop in the natural carbon cycle, returning to the atmosphere CO <sub>2</sub> that was originally removed by photosynthesis (IPCC, 1997).
Ozone Depletion Potential (ODP)	WMO 1992, 1995, 1998	kg eq. CFC-11	Some substances emitted by human activities lead to the breakdown of stratospheric ozone. This in turn cause a larger fraction of the sun's UV-B radiation to reach the earth's surface than in their absence. This can have harmful effects on human health, animal health, terrestrial and aquatic ecosystems, biochemical cycles, as well as on materials. The indicator used is the Ozone Depletion Potential (ODP). The ODP is defined as the ratio between ozone breakdown in a state of equilibrium due to annual emissions of a quantity of a substance released into the atmosphere and the breakdown of ozone in a state of equilibrium due to an equal quantity of CFC-11.
Acidification Potential (AP)	Hauschild and Wenzel 1998	kg eq. SO <sub>2</sub>	Acidifying substances cause a large number of diverse impacts on soil, groundwater, surface water, organisms, ecosystems and materials (buildings). Examples are fish dying in scandinavian lakes, forest decline and the crumbling of building materials. The impact indicator used is based on an assessment of the number of moles of hydrogen ions which can potentially be released to the environment from one mole of the substance in question.
Eutrofication Potential (EP)	Heijungs et al. 1992	kg eq. PO <sub>4</sub> <sup>3-</sup>	Eutrophication includes all impacts due to a too high level of macronutrients in the aquatic ecosystems. This enrichment may cause an undesirable shift in the composition of species and an increased production of biomass. In addition, high nutrient concentrations can also make surface water and groundwater unacceptable for water supply. An increased production of biomass may lead to low oxygen concentrations because the decomposition of this biomass needs oxygen. The impact indicator is based on the contribution of N and P to the average composition of aquatic organisms (C <sub>106</sub> H <sub>263</sub> O <sub>110</sub> N <sub>16</sub> P).
Energy Consumption (EC)	Frischknecht et al. 1998	MJ	Energy demand is an useful indicator of environmental impact and resource depletion. It represents a measure of the system's efficiency and implies lower uncertainty as compared to other impact categories. Included are the inputs of primary non-renewable energy sources, in MegaJoule. Renewable energy inputs are not taken into account, as these are regarded as sustainable.

In the classification step, the inputs and outputs are attributed to the impact categories they are expected to contribute. The contribution of the different substances is calculated by using the characterisation factors included in the references shown in table 5.5. All inputs and outputs are considered to contribute to these categories to their potential full amount, which means that the contribution of a substance to an impact category is not considered to diminish the contribution to another impact category). The results of characterisation are aggregated per impact category. Then, this yields one indicator per impact category.

### 5.1.11.2. Normalisation and weighting

By normalisation, the indicator result per impact category is given as a fraction of the contribution to this impact category of a certain region or average inhabitant, over a particular interval of time. The normalisation step makes it possible to compare the contributions of the different impact categories, since they are now in the same dimensions: e.g. a fraction of the annual contribution to this category from a reference system.

The reference region in this study is Europe. Therefore, normalisation has been based on the contribution of Western Europe in 1995. The data used (table 5.6) is from van Oers (2001), although the figure for EC which has been elaborated for this study is based on the consumption of coal, oil, gas and uranium in western Europe, according to that source and the calorific value of these energy sources.

Table 5.6. Normalisation factors for Western Europe in 1995.

Impact category	Units	Factor (kg/year)
Global Warming Potential (GWP)*	kg eq. CO <sub>2</sub> /year	4.82E+12
Ozone Depletion Potential (ODP)*	kg eq. CFC-11/year	8.30E+07
Eutrophication Potential (EP)*	kg eq. PO <sub>4</sub> <sup>3-</sup> /year	1.25E+09
Acidification Potential (AP)*	kg eq. SO <sub>2</sub> /year	2.94E+10
Energy consumption (EC)**	MJ	2.84E+13

\* Source: van Oers (2001).

\*\* Source: calculated from van Oers (2001).

Following normalisation, the results per impact category may be weighted. This means that the results for a certain category are multiplied by a weighting factor. Such a factor must be based on the relative importance of the particular impact category. This makes it possible to compare different categories and add them up to get one final LCA score. The weighting factors may be based on different approaches. For example, Guinée et al. (2002) recommend to derive these weighting factors on some form of panel method.

ISO 14.042 does not permit weighting in cases where the results of an LCA will be used for a comparative assertion, that is, comparison of products for which the results will be used externally. This would be the case in the present study. Nevertheless, it has been decided to aggregate the impact categories where characterised set of indicators need to be simplified. The aggregation method applied has been to simply sum up the normalised LCIA results, which means that implicitly all impact categories have the same importance (the weight factor is 1 for all of them).

## 5.2. Inventory Analysis

In the inventory analysis, data is collected and inputs and outputs are attributed to the processes. Data aggregation finally results in a list of all environmental inputs and outputs in the product system, namely, the inventory table. In the following sections the consumption of energy and chemicals is calculated for all treatments. Finally a summary table is shown for each scenario.

### 5.2.1. Energy consumption

In the baseline scenario, all AOPs generate hydroxyl radicals by means of electricity-consuming devices, namely an UV-A lamp and/or an ozoniser. The energy consumed by each treatment has been calculated taking into account the nominal power of the equipment, and the time required to achieve 15% DOC removal ( $t_{15\%}$ ) in the experiments. The lamp and the ozoniser have a power of 6 W and 120 W, respectively. Table 5.7 shows the calculation of electricity consumption per functional unit for all treatments.

Table 5.7. Calculation of electricity consumption per FU in the baseline scenario.

AOP	$t_{15\%}$ (hours)	Electricity consumed in experiment* (Wh)		Electricity consumed per FU** (kWh)
		Lamp	Ozoniser	
Ti	3	18		180
Ti+H <sub>2</sub> O <sub>2</sub>	1.75	10.5		105
Ti+Fe	0.5	3		30
Fe	1.25	7.5		75
O <sub>3</sub>	0.5		60	600
O <sub>3</sub> +UVA	0.25	1.5	30	300

\* Energy consumed for a batch of 0.1 litres.

In the second scenario the AOPs are assumed to produce OH· radicals by using direct sunlight, and therefore there is no electricity consumption at all. However, two treatments, O<sub>3</sub> and O<sub>3</sub>+UVA, are excluded from this scenario, since ozone can not be produced from direct sunlight.

### 5.2.2. Chemicals consumption

Four kind of chemicals are consumed by the AOPs: liquid oxygen, titanium dioxide, ferrous sulphate and hydrogen peroxide. The amount of oxygen consumed has been calculated based on  $t_{15\%}$  (table 5.8) and the following experimental conditions (Pérez et al. 2002): 330 cm<sup>3</sup> of oxygen per minute and a pressure of 0.5 bar; the temperature has been assumed to be 298 °K. Consequently, 81 g oxygen/hour are fed into the ozoniser.



Table 5.8. Calculation of oxygen consumption per FU.

AOP	t <sub>15%</sub> (hours)	Oxygen consumed in experiment* (g)	Oxygen consumed per FU (kg)
O3	0.5	40.5	405
O3+UVA	0.25	20.25	203

\* Oxygen consumed for a batch of 0.1 litres.

The amount of titanium dioxide, ferrous sulphate and hydrogen peroxide has been calculated based on the dose in ppm (table 5.9). At this moment it has to be taken into account that those treatments involving the use of titanium include a separation process and reuse of the catalyst 10 times. It has to be borne in mind that these inputs per functional unit are the same in both electricity and solar scenarios.

Table 5.9. Calculation of (pure) chemicals consumption per FU.

AOP	Dose (ppm)			Chemicals consumption per FU (kg)		
	TiO <sub>2</sub>	FeSO <sub>4</sub> ·7H <sub>2</sub> O*	H <sub>2</sub> O <sub>2</sub>	TiO <sub>2</sub>	FeSO <sub>4</sub> ·7H <sub>2</sub> O	H <sub>2</sub> O <sub>2</sub>
Ti	2000			0.2		
Ti+H <sub>2</sub> O <sub>2</sub>	2000		500	0.2		0.5
Ti+Fe	2000	100	500	0.2	0.01	0.5
Fe		100	500		0.1	0.5

\* 20 ppm iron (II) = 100 ppm FeSO<sub>4</sub>·7H<sub>2</sub>O

### 5.2.3. Transport of chemicals

A distance of 100 km has been considered to transport the chemicals to the wastewater plant. In this section the transport service in kg·km<sup>3</sup> is calculated. Hydrogen peroxide is most often marketed as diluted to 30%. Consequently, the mass of chemical transported has to be corrected for the water content, by dividing the amount consumed by 0.3. The calculation of kg·km is shown in table 5.10. These figures and a 16 ton truck model will be used to quantify the environmental burdens of this transport.

Table 5.10. Calculation of the total transport service per FU.

AOP	Chemicals consumption per FU (kg)				Total	kgkm
	TiO <sub>2</sub>	FeSO <sub>4</sub> ·7H <sub>2</sub> O	H <sub>2</sub> O <sub>2</sub> 30%	O <sub>2</sub>		
Ti	0.2				0.2	20
Ti+H <sub>2</sub> O <sub>2</sub>	0.2		1.67		1.87	187
Ti+Fe	0.2	0.01	1.67		1.88	188
Fe		0.1	1.67		1.77	177
O3				405	405	40,500
O3+UVA				203	203	20,300

<sup>3</sup> 1 kgkm refers to transporting 1kg to a distance of 1 km.

## 5.2.4. Summary tables

Table 5.11 and 5.12 summarizes the processes attributed to each AOP in the baseline scenario (using electricity) and in the solar scenario, respectively. All these data have been introduced in the Simapro 6.0 software, using the Ecoinvent datasets detailed in table 5.4, thus allowing to obtain an aggregated inventory table (which includes only inputs from nature and outputs to nature), that constitutes the basis for LCIA.

Table 5.11. Summary of inputs from technosphere per FU in the baseline scenario.

Inputs	Treatments					
	Ti	Fe	Ti+H2O2	Ti+Fe	O3	O3+UVA
Electricity (kWh)	180	75	105	30	600	300
TiO <sub>2</sub> (kg)	0.2		0.2	0.2		
FeSO <sub>4</sub> ·7H <sub>2</sub> O (kg)		0.1		0.01		
H <sub>2</sub> O <sub>2</sub> 30% (kg)		1.67	1.67	1.67		
O <sub>2</sub> (kg)					405	203
Truck 16 t (kgkm)	20	177	187	188	40,500	20,300

Table 5.12. Summary of inputs from technosphere per FU in the solar scenario.

Inputs	Treatments			
	Ti	Fe	Ti+H2O2	Ti+Fe
TiO <sub>2</sub> (kg)	0.2		0.2	0.2
FeSO <sub>4</sub> ·7H <sub>2</sub> O (kg)		0.1		0.01
H <sub>2</sub> O <sub>2</sub> 30% (kg)		1.67	1.67	1.67
Truck 16 t (kgkm)	20	177	187	188

## 5.3. Life Cycle Impact Assessment

Once the aggregated inventory table has been obtained, the environmental interventions are classified and characterisation factors are applied, giving rise for each AOP to the so-called environmental profile. In the following sections, the results for all treatments in both scenarios are analysed and discussed at the characterisation level, although in some cases weighting is applied.

### 5.3.1. Baseline scenario

The results of the first scenario, where the AOPs are assumed to consume electricity from the grid, are presented and discussed below.

#### 5.3.1.1. Contribution analysis

This first analysis is not aimed at comparing the different treatments among them, but at identifying the critical sub-systems for each treatment and impact category. For this purpose the characterisation results are used, disaggregating them so that the contribution of the chemical products, electricity and transports can be analysed. Figure 5.4 shows, for each treatment, these relative contributions. Every impact indicator is expressed as 100%, being the contribution of a sub-system a fraction of this figure. The numerical data on which these graphics are based can be found in appendix 5.1.

From Figure 5.4 it can be highlighted that electricity production, either to run the UVA lamp or to produce ozone, is by far the most critical sub-system, accounting for at least 70% of the contribution to all impact categories in all treatments. In some cases electricity is responsible of almost 100% of the contribution. This noticeable impact is caused by the energy intensity of the AOPs and the characteristics of the UCTE mix for electricity production, which relies in a considerable extent on fossil fuels.

The contribution of chemicals is low, or even negligible. Only in the treatments using ozone, oxygen production appears to be a considerable contributor to all categories, being responsible of about 20-30% of the overall impacts. Only in the Fe+Ti treatment,  $\text{TiO}_2$  and  $\text{H}_2\text{O}_2$  cause a relevant contribution: altogether contribute 25% in ODP, and about 10-15% in the remaining categories. On the other hand,  $\text{FeSO}_4$  has a negligible contribution in those treatments using this salt, which can be explained by the low dose applied.

Transporting the chemicals to the wastewater plant implies a relatively low impact, as compared to that of electricity production. In the ozone-based treatments, the quantity of oxygen to be transported is considerable, but its transport only implies 5%-15% of the overall contribution, depending on the impact category.

As a summary, it can be stated that the AOPs analysed are mainly energy-intensive, and this leads to an environmental impact proportional to the overall energy consumption of each treatment.

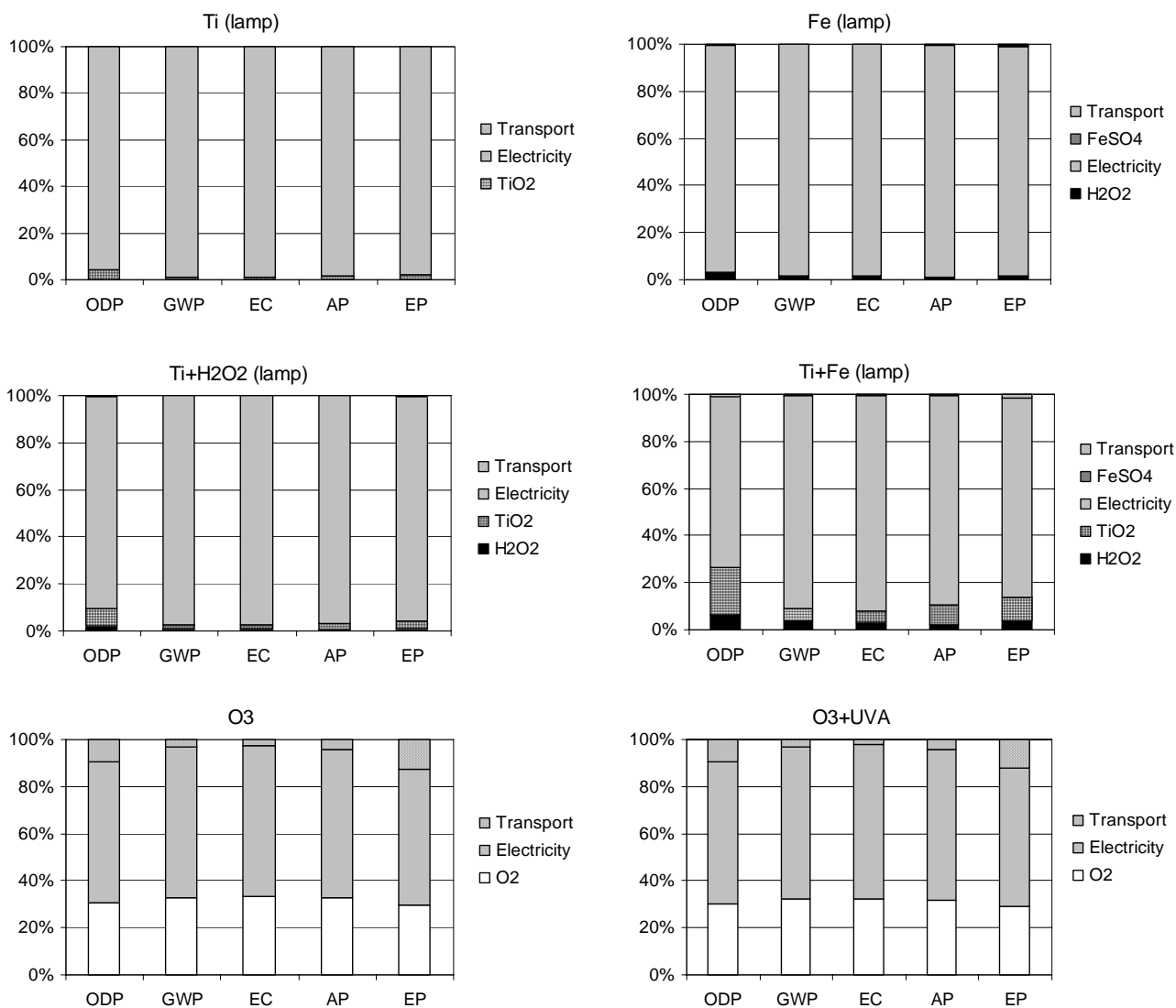

Figure 5.4. Contribution of sub-systems in the characterisation results of the baseline scenario.

### 5.3.1.2. Comparative analysis

In this section the different treatments are compared under the baseline scenario conditions. Figure 5.5 shows the overall characterisation results for Global Warming Potential, in which also the contribution of the different sub-systems can be seen. The relative pattern in the other impact categories is very similar (see appendix 5.1), therefore figure 5.5 on its own allows to compare the environmental performance of all treatments.

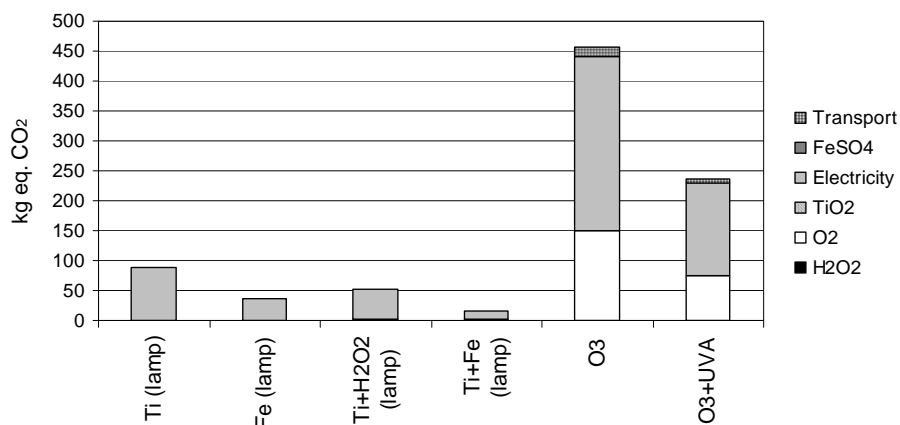

Figure 5.5. Global Warming Potential for all treatments in the baseline scenario

From figure 5.5, the treatments can be ranked according to their environmental impact as follows:

- O<sub>3</sub> and O<sub>3</sub>+UVA have the higher impact, and comparing their results it can be noticed that combining ozone with UVA light decreases the impact about 50%.
- The lamp-based AOPs, that is, the remaining treatments, cause a substantially lower environmental impact, being the higher Ti and the lower Ti+Fe (5 times lower). It is noticeable that photocatalysis using only TiO<sub>2</sub> (Ti) obtains the worst results in this group, but when this technique is combined with photo-Fenton (Fe+Ti), it appears as the best treatment, suggesting that a synergistic effect occurs.

The first question that arises is the big difference between using or not using ozone. As it was discussed in the hypothesis and limitations of the study (section 5.1.8), there is an order of magnitude between the efficiency of the laboratory ozoniser and that of an industrial device. From the inventory data it has been calculated an energy consumption of about 80 kWh/kg ozone produced, while from literature data a figure of 10-15 kWh/kg ozone is reported for an industrial ozoniser (EIPPCB, 2000). Nevertheless, the UV-A lamp and the reactor used is also far from being optimized. In consequence, the comparison is apparently fair.

### 5.3.2. Solar scenario

In this scenario, the AOPs are assumed to use solar light as energy source to provide photons for use in the chemical process. Since ozone has to be produced using electricity, both O<sub>3</sub> and O<sub>3</sub>+UVA treatments are excluded from this scenario.

#### 5.3.2.1. Contribution analysis

Figure 5.6 shows, for each treatment, the relative contributions of the sub-systems to the impact categories. In this scenario the sub-systems consist only of production and delivery of chemicals. Every impact category is expressed as 100% and the contribution of a sub-system is therefore a fraction of this figure. The numerical data on which these graphics are based can be found in appendix 5.1.

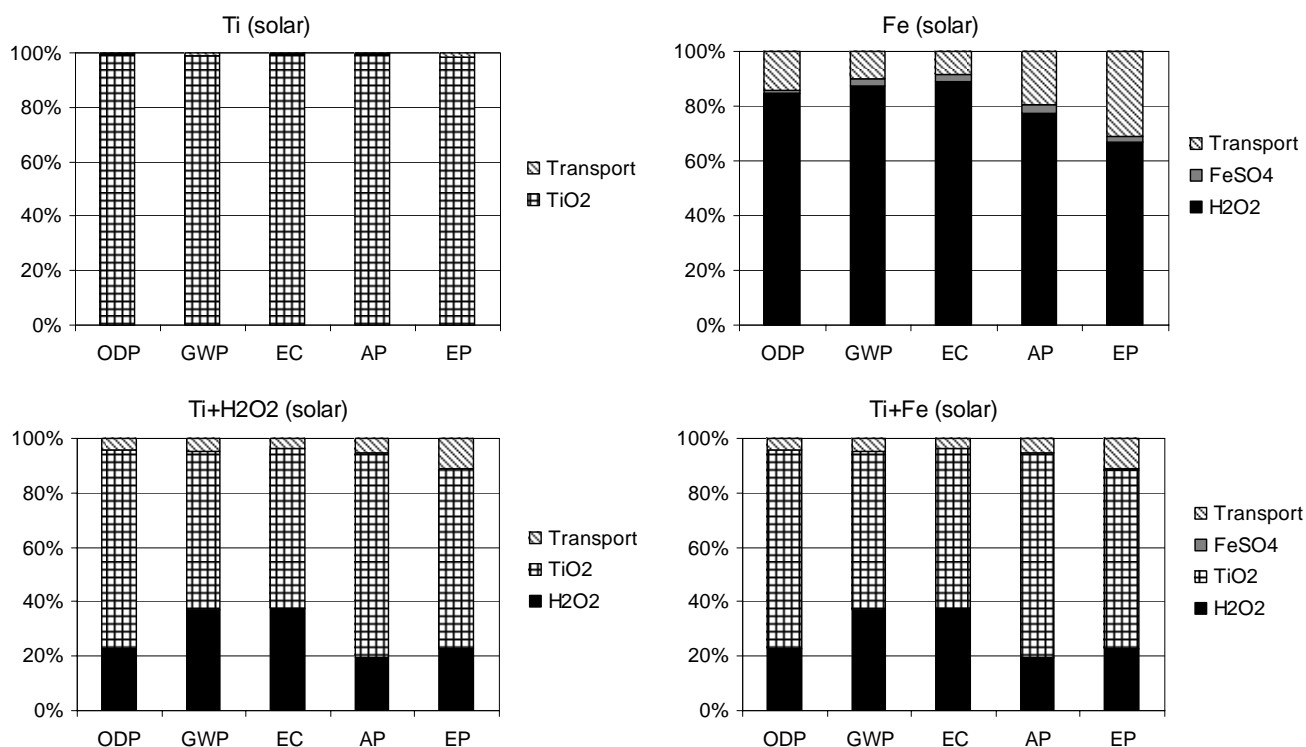

Figure 5.6. Contribution of sub-systems in the characterisation results of the solar scenario.

The contributions to impacts in this scenario are originated by H<sub>2</sub>O<sub>2</sub>, TiO<sub>2</sub> and FeSO<sub>4</sub>. There is neither electricity consumption, nor oxygen consumption, since oxygen is only used to produce ozone, a sub-system excluded from this scenario.

In the Ti treatment, 100% of the impacts are produced by TiO<sub>2</sub> since this product is the only input to the system. In the other three treatments, combining the use of TiO<sub>2</sub>, H<sub>2</sub>O<sub>2</sub> and FeSO<sub>4</sub>, the impacts are originated mainly by TiO<sub>2</sub> and H<sub>2</sub>O<sub>2</sub>, with variable contributions, depending on the impact category. The contribution of FeSO<sub>4</sub> is rather negligible; this is due to the low dose (20 ppm iron) but also to the fact that this chemical is a by-product of the steel industry and hence it is charged with few environmental burdens. Finally, as in the previous scenario, the impact of transport is not very important, being its maximum contribution 25% of EP in the Fe treatment.

### 5.3.2.2. Comparative analysis

Figure 5.7 shows the overall characterisation results, representing the most impacting treatment as 100% for each category. The numeric data on which these graphics are based can be found in appendix 5.1.

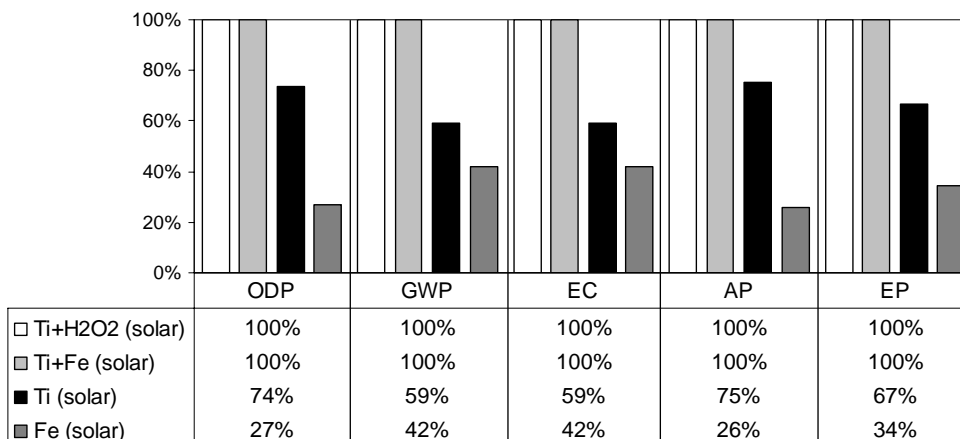

Figure 5.7. Characterisation results for all treatments in the solar scenario.

The question in this scenario is: if the AOPs are to be applied using solar energy, which of the treatments analyzed would have the least environmental impact?. In Figure 5.7 it can be observed that Fe appears as the best option. One of the important changes to observe in this scenario is that the best treatment in the baseline scenario, Ti+Fe, is far from being so in this scenario, suggesting that it is a good option when the impact of energy production is the main concern, but when it is not, as it is the case in this scenario, the extra consumption of chemicals is not justified.

These results, however, should be handled with care, since the functional unit used is not as suitable in this scenario as it was for the other scenario: in the baseline energy consumption was calculated based on DOC removal by means of reaction time, and chemicals were allocated by means of volume of treated water. As discussed in section 5.8.1.4, the method for calculating chemicals consumed is not satisfactory. Nevertheless, as it has been shown in the results, the critical parameter in those scenarios is by far energy, and not chemicals, reason for which the calculation method for chemicals is not considered to have a serious influence. This, on the other hand, is completely different in the solar scenario, because energy consumption is no longer taken into account (solar light is clean), and therefore chemicals become the critical factor. In order to assess if the results of the solar scenario could be influenced by the functional unit used, a sensitivity analysis is performed in the next section.

### 5.3.2.3. Comparative analysis changing the functional unit

In the solar scenario, the environmental impact of energy is set to zero, as solar energy is directly consumed. Therefore, the only inputs to the system are chemical products, which are assigned to the functional unit on the basis of volume of treated water, regardless of the amount of DOC removed. In the baseline scenario this has been found not to be a problem, since the hotspot is electricity production, and the contribution of chemicals is very low. Nevertheless, in the solar scenario this method could lead to wrong results, since these only depend on the impact of chemical products.

The functional unit, as defined in section 5.1.5 does not allow another method for calculation of chemicals consumption, because it is not possible to know which fraction of the dose applied has to be assigned to the 15% DOC removed. For this reason, in this sensitivity analysis the functional unit is changed to be more in accordance with these limitations. The new functional unit is defined as:

*“Removal of 1kg DOC from a kraft pulp mill wastewater as shown in Table 5.1”.*

This is the functional unit used by Pérez and coworkers (2002) in the economic study on which the present LCA is based. Using this functional unit, which is also in accordance with the system function, chemicals consumption is directly assigned to the amount of DOC removed by each treatment.

From the amount of DOC removed by each treatment after the 3 hours experiment (Table 5.2), the dose of chemicals applied, and taking into account the recovery of catalysts as well as the transport distances, a new inventory table for the solar scenario can be obtained (Table 5.13).

Apart from the limitations discussed in section 5.1.5 for this functional unit, there is another limitation when this scenario is applied: we are not taking into account that solar energy is more intense than the UV-A lamp considered, in the wavelength range in which the AOPs are active. This higher intensity would enhance the processes involving photo-Fenton reactions, but it is not likely to do so in those using only TiO<sub>2</sub>, since the photoactivity of this catalyst attains a saturation level with the current lamp intensity (Pérez et al. 1997, 2002). Therefore, a higher DOC reduction after the 3 hours experiment would be expected in some AOPs than it was observed with the UV-A lamp. This will be taken into account when interpreting the results of this sensitivity analysis.

Table 5.13. Summary of inputs from technosphere per FU in the solar scenario, recalculated for the new functional unit.

Inputs	Treatments			
	Ti	Fe	Ti+H2O2	Ti+Fe
TiO <sub>2</sub> (kg)	3		2.2	1.5
FeSO <sub>4</sub> ·7H <sub>2</sub> O (kg)		0.8		0.08
H <sub>2</sub> O <sub>2</sub> 30% (kg)		12.7	18	12.7
O <sub>2</sub> (kg)				
Truck 16 t (kgkm)	300	1,350	2,020	1,428

The characterisation results obtained using the re-defined functional unit can be seen in figure 5.8. As already happened to the original functional unit, the AOP having the lowest environmental impact is the Fe treatment. However, some changes can be observed: the impact of the Ti treatment increase remarkably, and that of the Ti+Fe treatment decrease also in a considerable extent.

Considering that solar energy would increase the rate of AOPs involving photo-Fenton reactions respect to heterogeneous photocatalysis, it can be stated that Fe is the preferable option in this scenario.



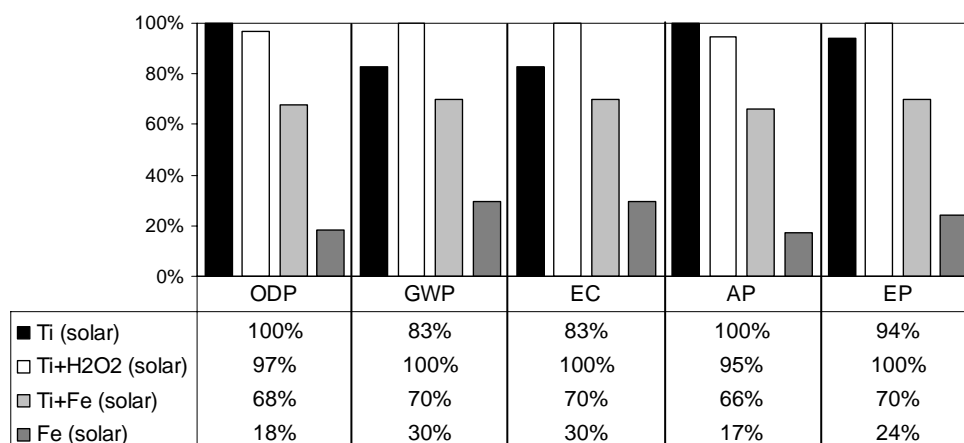

Figure 5.8. Characterisation results for all treatments in the solar scenario, recalculated for the new functional unit.

### 5.3.3. Electricity vs. solar energy

In Figure 5.9 the weighted results for both scenarios, using the original functional unit, are represented together, showing for each treatment the differences in impacts, aggregated in a single score. On the other hand, Table 5.14 shows for each treatment the weighted environmental saving of the solar scenario with regard to the first scenario. In this case characterisation results are not shown to avoid an excessive amount of information (4 treatments x 2 scenarios x 5 impact categories).

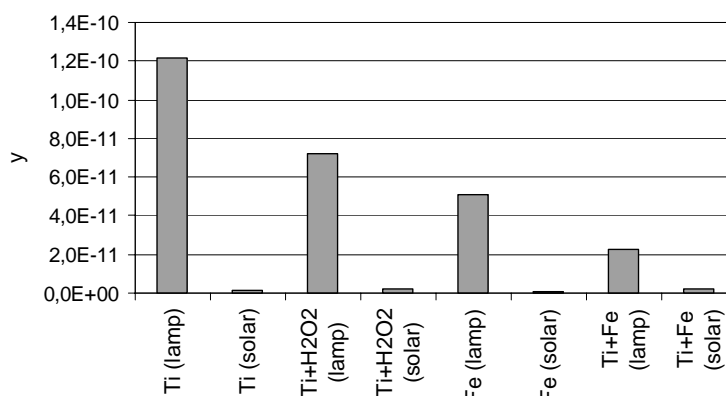

Figure 5.9. Weighted results for all treatments in the baseline and solar scenarios.

Table 5.14. Weighted impact reduction for each treatment in the solar scenario, as compared to the baseline scenario.

Ti	Fe	Ti+H2O2	Ti+Fe
99%	98%	97%	90%

The potential improvements of using solar energy as a source of photons for the AOPs can be clearly seen in figure 5.9 and Table 5.14. The overall environmental impact, expressed as single score, decreases about 90% or more for each treatment with regard to the same treatment in the baseline scenario. This is of special interest in countries like Spain, where solar irradiation is intense and relatively constant.

## 5.4. Cost Assessment

Several AOPs have been environmentally assessed, obtaining information on their relative “greenness”. The present study has been based on a previous work (Pérez et al. 2002) where these AOPs were assessed from an economic point of view. However they are here recalculated, to be in accordance with the functional unit used in the LCA (see section 5.1.5). The methodology for this cost analysis is described below:

- The cost is calculated per functional unit, i.e. the removal of 15% DOC from a kraft pulp mill wastewater having the composition shown in Table 5.1.
- Capital investments are excluded. Only chemical and energy costs are taken into account. As opposed to the methodology used by Pérez et al. (2002), the spent catalysts (TiO<sub>2</sub> and iron) are taken into account, in the same way as it has been done in the LCA. The unitary prices used are shown in Table 5.15.

Table 5.15. Unitary costs considered for energy and chemicals.

Product	Price (€)	Source
Electricity (kWh)	0.07	Assumption
TiO <sub>2</sub> (kg)	19.34	Quimidroga
O <sub>2</sub> (kg)	0.12	Trailigaz (Perrot 2004)
FeSO <sub>4</sub> (kg)	0.25	Albaida, Recursos Naturales y Medio Ambiente
H <sub>2</sub> O <sub>2</sub> 30% (kg)	0.53	Albaida, Recursos Naturales y Medio Ambiente

In Table 5.16 the cost per functional unit and treatment is summarised and disaggregated showing the contribution of chemicals and energy, whereas in Figure 5.15 the overall cost is displayed as a percentage of the most expensive treatment.

Table 5.16. Economic cost per functional unit for all treatments in both scenarios.

Treatment	Total	Electricity	O <sub>2</sub>	TiO <sub>2</sub>	FeSO <sub>4</sub>	H <sub>2</sub> O <sub>2</sub>
Ti	16,47	12,60		3,87		
Fe	6,15	5,25			0,03	0,88
Ti+H <sub>2</sub> O <sub>2</sub>	12,10	7,35		3,87		0,88
Ti+Fe	6,85	2,10		3,87	0,003	0,88
O <sub>3</sub>	90,60	42,00	48,60			
O <sub>3</sub> +UVA	46,41	22,05	24,36			
Ti (solar)	3,87			3,87		
Fe (solar)	0,90				0,03	0,88
Ti+H <sub>2</sub> O <sub>2</sub> (solar)	4,75			3,87		0,88
Ti+Fe (solar)	4,75			3,87	0,003	0,88

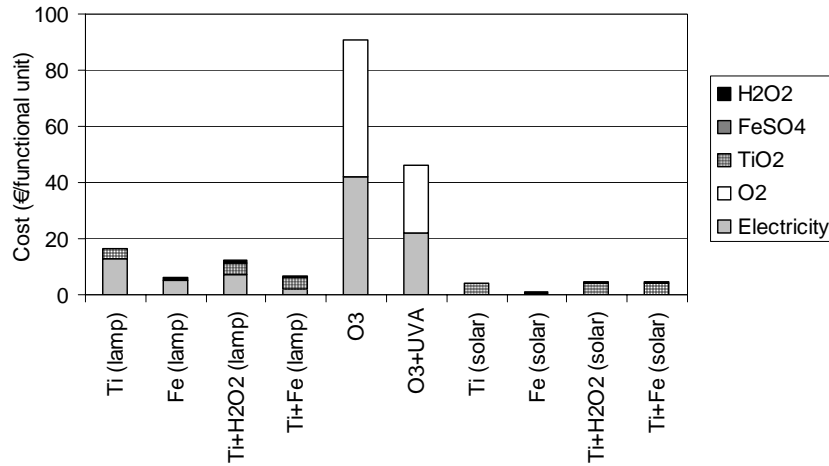

Figure 5.10. Economic cost per functional unit for all treatments in both scenarios.

The results of the cost assessment show that the main cost components are electricity, oxygen and titanium dioxide. The most expensive treatments are O3 and O3+UVA, although the latter decreases the cost about 50% as compared to O3. All the remaining treatments have a cost below 20% that of O3.

Among the lamp-based treatments, Ti is the most expensive, being Fe and Ti+Fe the cheapest options. When the lamp-based treatments are assumed to use solar light, Fe is the cheapest, as it avoids the use of titanium dioxide, a relatively expensive catalyst.

## 5.5. Integration of Environmental Impact and Cost

So far, the AOPs have been evaluated separately with respect to their ecological and economic performances. At this point, both components can be combined in what could be called an Eco-efficiency assessment. This is done in this section in a very simple way: the environmental impact of each AOP, represented by the weighted results of the LCIA, is plotted against the economic cost (figure 5.11), in a similar way as it is done by the BASF Eco-efficiency method presented in chapter 4. By this approach, the treatments located near the upper right corner of the graphic are the least eco-efficient, whereas those located close to the origin of the axis are the most eco-efficient.

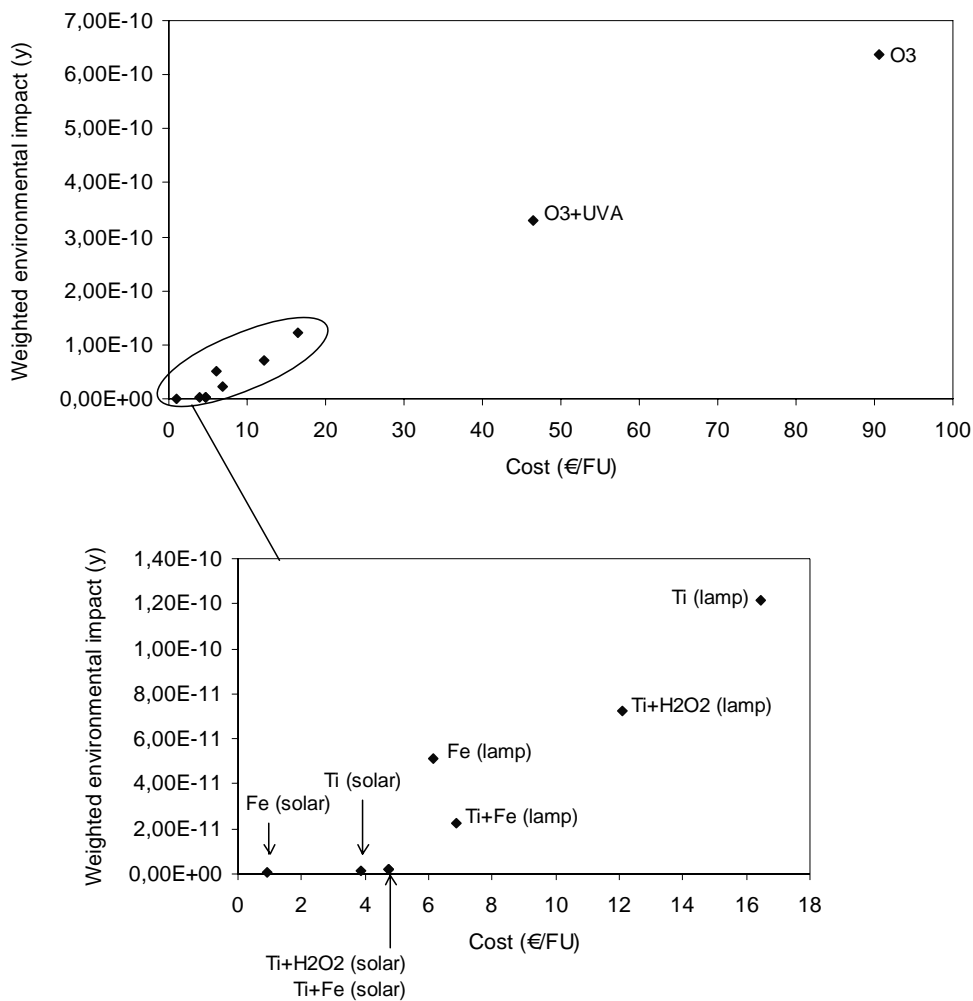

Figure 5.11. Combination of weighted environmental impact and economic cost for all treatments.

The combination of the environmental and economic data in figure 5.11 allows to draw the following conclusions:

- There is a certain linearity between environmental impact and cost, as in general terms those treatments consuming more energy and chemicals are more expensive than those consuming less.
- O3 and O3+UVA are the least eco-efficient AOPs, although O3+UVA improves substantially, since impact and cost is reduced to 50%.

- The most eco-efficient treatments, among those using a lamp, are Fe and Ti+Fe; the former has a slightly higher environmental impact, while the latter has a slightly higher cost.
- The lamp-based treatments are less eco-efficient than those using solar energy; the most eco-efficient in this study is Fe(solar).

## 5.6. Conclusions and Recommendations

In this streamlined LCA, the interpretation phase is reduced to the formulation of conclusions and outlook, since several elements usually included in the interpretation, such as contribution analysis, or sensitivity analysis, have been already carried out in the LCIA section.

### 5.6.1. Main conclusions to the case study

In the present LCA, six options for advanced oxidation of effluents from kraft pulp bleaching have been assessed:

- Heterogeneous photocatalysis (Ti)
- Photo-Fenton (Fe)
- Heterogeneous photocatalysis in combination with hydrogen peroxide (Ti+H<sub>2</sub>O<sub>2</sub>)
- Heterogeneous photocatalysis in combination with photo-Fenton (Ti+Fe)
- Ozonation in the dark (O<sub>3</sub>)
- Ozonation in the presence of UV-A light (O<sub>3</sub>+UVA)

These options have been assessed under two possible scenarios or conditions, concerning the energy sources to run the AOPs:

- Electricity to run the lamp or the ozoniser (baseline scenario)
- Solar light (in this scenario treatments involving the use of ozone are excluded)

The key findings of this study are summarised in the following sections.

#### 5.6.1.1. Sub-systems

- ☑ AOPs are more energy-intensive than material-intensive processes. For this reason, the main environmental impact is generally caused by the electricity consumed. In the baseline scenario, for instance, electricity production is responsible for at least 70% of the contribution to the different impact categories. In the solar scenario it is zero, as solar light is a clean energy.
- ☑ As a consequence, in the baseline scenario chemical products contribute moderately to the different environmental impacts. The most remarkable contribution is that of oxygen, which is responsible of 20-30% of the overall impact in ozone-based treatments.
- ☑ Transport of the chemical products to the wastewater plant implies an environmental impact which is negligible in most treatments, except in O<sub>3</sub> and O<sub>3</sub>+UVA, due to the large amount of oxygen that has to be delivered.

#### 5.6.1.2. Scenarios

- ☑ The use of solar energy as a source of photons (scenario 3), is the best option for all the photo-assisted AOPs, since this energy source is completely clean. Depending on the AOP, the weighted environmental impact is reduced between 90-99% with regard to the baseline scenario.

#### 5.6.1.3. Treatments

- ☑ From the results obtained in the solar scenario, with regard to the other scenarios, it can be concluded that all solar AOPs are better options than any AOP using a conventional energy source.
- ☑ Photo-Fenton reactions using solar light as source of photons has been identified as the best environmental option among those included in this study.
- ☑ Ozonation has the higher environmental impact, due to the energy consumption of producing oxygen and ozone. The results have shown that combining ozonation with UVA irradiation decreases the environmental impact about 50%. Using solar energy instead of artificial UV-A light would probably lead to further decrease of the environmental impact, although this has not been assessed in the present LCA.
- ☑ When the energy used is electricity from the grid, the AOP showing the lowest environmental impact is the coupling of heterogeneous photocatalysis with photo-Fenton, which has an environmental impact about 80% lower than heterogeneous photocatalysis alone, which is the photo-assisted AOP with the worst results.

#### 5.6.1.4. Cost

- ☑ The results of the cost assessment show that the main cost components are electricity, oxygen and titanium dioxide. The most expensive treatments are those using ozone, although combining ozone with artificial UV-A light decreases the cost about 50% as compared to ozone only. All the remaining treatments have a cost below 20% that of ozonation in the dark.
- ☑ Among the lamp-based treatments, heterogenous photocatalysis is the most expensive, being photo-Fenton and the coupling of heterogeneous photocatalysis with photo-Fenton the cheapest options. When the lamp-based treatments are assumed to use solar light, photo-Fenton is the cheapest, as it avoids the use of titanium dioxide, a relatively expensive catalyst.

#### 5.6.1.5. Eco-efficiency

- ☑ The AOPs using ozone are the least eco-efficient, although irradiation with artificial UV-A light improves substantially, since impact and cost is reduced to 50%.
- ☑ The most eco-efficient treatments, among those using a lamp, are photo-Fenton and the coupling of heterogeneous photocatalysis with photo-Fenton; the former has a slightly higher environmental impact, while the latter has a slightly higher cost.
- ☑ The lamp-based treatments are less eco-efficient than those using solar energy; the most eco-efficient in this study is photo-Fenton using solar light.

### 5.6.2. Further research needs

The present work is a preliminary LCA of different emerging technologies for wastewater treatment. It is therefore not aimed at excluding processes from potential research and application if their results are not favourable, but at gaining

insight into the environmental impact of these processes and their potential advantages or disadvantages when compared among them. In spite of this preliminary nature, however, it has been possible to draw some conclusions in the last section, and also it is possible here to recommend the following priority actions:

- ☑ Similar studies should be performed when these technologies are developed in pilot plants and industrial scale, to better approach the real work conditions. This would allow for a more precise environmental and economic assessment.
- ☑ Solar applications should be promoted in the AOP research field, specially in geographical areas like the mediterranean basin, where this energy source has a great potential. In this way, the group of Solar Chemistry of Plataforma Solar de Almería (PSA) and the group of photocatalysis of UAB are working together in research applications of solar light to photocatalytic processes.
- ☑ If AOPs are to be applied using a conventional energy source, such as electricity, the most important environmental criteria to bear in mind by researchers and engineers is to maximize energy efficiency, since the present study has shown that energy production is the main source of environmental impacts.



## References to Chapter 5

- Althaus H J, Chudacoff M, Hischier R, Jungbluth N, Primas A, Osses M. 2004. *Life Cycle Inventories of Chemicals*. Final report ecoinvent 2000 No. 8, Swiss Centre for Life Cycle Inventories, Duebendorf, Switzerland.
- Bauer R, Fallmann H. 1997. *The Photo-Fenton oxidation. A cheap and efficient wastewater treatment method*. Research on Chemical Intermediates, 23 (4), pp. 291-388.
- Dones R, Bauer C, Burger B, Faist M, Frischknecht R, Heck T, Jungbluth N, Röder A. 2004. *Sachbilanzen von Energiesystemen: Grundlagen für den ökologischen Vergleich von Energiesystemen und den Einbezug von Energiesystemen in Ökobilanzen für die Schweiz*. Final report ecoinvent 2000 No. 6, Paul Scherrer Institut Villigen, Swiss Centre for Life Cycle Inventories, Switzerland.
- EIPPCB. 2000. *Reference Document on Best Available Techniques in the pulp and Paper Industry*. European Commission. Institute for Prospective Technological Studies (Sevilla). Available at: <http://eippcb.jrc.es>
- Fernández-Ibáñez P, Blanco J, Malato S, de las Nieves F J. 2003. *Application of the colloidal stability of TiO<sub>2</sub> particles for recovery and reuse in solar photocatalysis*. Water Research, 37, pp. 3180-3188.
- Frischknecht R, Hofstetter P, Knoepfel I, Dones R, Hollinger E, et al. 1994. *Ökoinventar für Energiesysteme*. Laboratorium für Energiesysteme. ETH Zürich, PSI Villigen.
- Frischknecht R, Heijungs R, Hofstetter P. 1998. *Einstein's lessons for energy accounting in LCA*. International Journal of Life Cycle Assessment, 3 (5), pp. 266-272.
- Frischknecht R, Althaus H J, Doka G, Dones R, Hellweg S, Hischier R, Jungbluth N, Nemecek T, Rebitzer G, Spielmann M. 2003. *Code of Practice*. Final report ecoinvent 2000 No. 2, Swiss Centre for Life Cycle Inventories, Duebendorf, Switzerland. [www.ecoinvent.ch](http://www.ecoinvent.ch)
- Frischknecht R, Althaus H J, Doka G, Dones R, Heck T, Hellweg S, Hischier R, Jungbluth N, Nemecek T, Rebitzer G, Spielmann M. 2004. *Overview and Methodology*. Final report ecoinvent 2000 No. 1, Swiss Centre for Life Cycle Inventories, Duebendorf, Switzerland. [www.ecoinvent.ch](http://www.ecoinvent.ch)
- Goedkoop M, Spriensma R. 2000. *The Eco-indicator 99 A damage oriented method for Life Cycle Impact Assessment*. Methodology Report, Second Edition. Pré Consultants B.V. Amersfoort, The Netherlands.
- Guinée J B, Gorree M, Heijungs R, Huppes G, Kleijn R, Udo de Haes H A, Van der Voet E, Wrisberg M N. 2002. *Life Cycle Assessment. An operational guide to ISO standards*. Volume 1, 2, 3. Centre of Environmental Science, Leiden University (CML), The Netherlands.
- Habersatter K. 1996. *Ökoinventare für Verpackungen*. Bundesamt Für Umwelt, Wald, Und Landschaft (BUWAL). Schriftenreihe Umwelt 250, Bern, 1996.
- Hauschild M, Wenzel H. 1998. *Environmental Assessment of Products*. Vol. 2: Scientific background. Chapman & Hall.
- Heijungs R, Guinée J, Huppes G, Lankreijer R M, Udo de Haes, E, Wegener A, Anselms A, Eggels P G, Van Duin R, Goede H P. 1992. *Environmental Life Cycle Assessment of Products. Guide and Backgrounds*. Centre of Environmental Science, Leiden University (CML), Leiden University, The Netherlands.
- Houghton J T, Meira Filho L G, Bruce J, Lee H, Callander B A, Haites E, Harris N, Maskell K (Eds.). 1994. *Climate change 1994. Radiative forcing of climate change an evaluation of the IPCC IS92 Emissions scenarios*. Cambridge University Press, Cambridge.
- Houghton J T, Meira Filho L G, Callander B A, Harris N, Maskell K, Kattenberg A (Eds.). 1995. *Climate change 1995. The science of climate change*. Contribution of WGI to the second assessment report of the intergovernmental panel on climate change. Cambridge University Press, Cambridge.
- Huppes G, Schneider F (Eds.). 1994. *Proceedings of the European Workshop on Allocation in LCA*. Centre of Environmental Science of Leiden University, Section Substances & Products. Leiden 24-25 feb. 1994.
- IPCC. 1997. *IPCC Guidelines for National Greenhouse Gas Inventories*. Three Volumes. [www.ipcc.ch](http://www.ipcc.ch)

- ISO. 1997. *ISO 14040: Environmental management – Life cycle assessment – Principles and Framework*. Geneva, Switzerland.
- ISO. 1998. *ISO 14041: Environmental management – Life cycle assessment – Goal and Scope Definition and Inventory Analysis*. Geneva, Switzerland.
- ISO. 1999. *ISO 14042: Environmental management – Life cycle assessment – Life Cycle Impact Assessment*. Geneva, Switzerland.
- Malato S, Blanco J, Maldonado M I, Fernández-Ibáñez P, Campos A. 2000. *Optimising solar photocatalytic mineralisation of pesticides by adding inorganic oxidising species; application to the recycling of pesticide containers*. *Applied Catalysis B: Environmental*, 28, pp. 163–174.
- Malato S, Blanco J, Vidal A, Richter C. 2002. *Photocatalysis with solar energy at a pilot-plant scale: an overview*. *Applied Catalysis B: Environmental*, 37, pp. 1-15.
- Pérez M, Torrades F, García-Hortal J A, Domènech X, Peral J. 1997. *Removal of organic contaminants in paper pulp treatment effluents by TiO<sub>2</sub> photocatalyzed oxydation*. *Journal of Photochemistry and Photobiology A: Chemistry* (109), 281-286.
- Pérez M, Torrades F, Domènech X, Peral J. 2001. *Removal of organic contaminants in textile mill effluents by Fenton and Photo-Fenton reactions*. In: Naik A. (Ed.). *Conference Proceedings of the 2001 International Textile Congress*. Terrassa. Vol. 1, pp. 346-353.
- Pérez M. 2001. *Degradation of organic compounds in paper and textile industrial wastewaters by advanced oxidation processes*. Doctoral Thesis, Escola Tècnica Superior d'Enginyeria Industrial de Terrassa, Departament d'Enginyeria Química, Universitat Politècnica de Catalunya.
- Pérez M, Torrades F, Peral J, Domènech X. 2002. *Removal of organic contaminants in paper pulp effluents by AOPs: an economic study*. *Journal of Chemical Technology and Biotechnology*, 77, pp. 525-532.
- Perrot J Y. 2004. *Personal communication*. Industrial applications manager, Trailigaz Compagnie Générale de l'Ozone. Garges-lès-Gonesse, France.
- Spielmann M, Kägi T, Tietje O. 2004. *Life Cycle Inventories of Transport Services*. Final report ecoinvent 2000 No. 14, Swiss Centre for Life Cycle Inventories, Duebendorf, Switzerland.
- Todd J A. 1995. *Streamlining LCA concepts and thoughts*. In: Curran M A. *Life Cycle Assessment*. Ed. McGraw-Hill.
- Torrades F, Peral J, Pérez M, Domènech X, García J A, Riva M C. 2001. *Removal of organic contaminants in bleached kraft effluents using heterogeneous photocatalysis and ozone*. *Tappi Journal*, 84 (6), p. 63.
- Udo de Haes H A, Jolliet O, Finnveden G, Hauschild M, Krewitt W, Muller-Wenk R. 1999. *Best available practice regarding impact categories and category indicators in life cycle impact assessment – background document for the second working group on life cycle impact assessment of SETAC-Europe (WIA 2)*. *International Journal of Life Cycle Assessment*, 4 (2), pp. 66-74.
- Van Oers L, Huijbregts M, Huppes G, Koning A de, Suh S (eds). 2001. *LCA normalization data for the Netherlands 1997/1998, Western Europe 1995 and the World 1990 and 1995*. RIZA Lelystad and CML, Leiden University, Leiden, The Netherlands. [www.leidenuniv.nl/cml/lca2/index.html](http://www.leidenuniv.nl/cml/lca2/index.html)
- Weitz K A, Todd J A, Curran M A, Malkin M J. 1996. *Streamlining Life Cycle Assessment Considerations and a report on the state of the practice*. *International Journal of Life Cycle Assessment*, 1 (2), pp. 79-85.
- WMO. 1992. *Scientific assessment of ozone depletion: 1991*. Report n° 25. Geneva.
- WMO. 1995. *Scientific assessment of ozone depletion: 1994*. Report n° 37. Geneva.
- WMO. 1998. *Scientific assessment of ozone depletion: 1998*. Report n° 44. Geneva.

## Appendix 5.1. Life Cycle Impact Assessment tables

### Characterisation

The following tables show for each treatment and scenario, the characterisation results, disaggregated by sub-systems. At the end of this section, also the characterisation results for the sensitivity analysis performed in the study are shown.

Table A.5.1. Characterisation results for heterogenous photocatalysis (Ti) in the baseline scenario.

Impact category	Units	Total	TiO <sub>2</sub>	Electricity	Transport
ODP	kg eq. CFC-11	3.80E-06	1.67E-07	3.63E-06	9.84E-10
GWP	kg eq. CO <sub>2</sub>	8.82E+01	8.80E-01	8.73E+01	7.37E-03
EC	MJ	1.94E+03	1.75E+01	1.93E+03	1.21E-01
AP	kg eq. SO <sub>2</sub>	4.55E-01	6.96E-03	4.48E-01	5.23E-05
EP	kg eq. phosphate	2.42E-02	4.69E-04	2.37E-02	8.64E-06

Table A.5.2. Characterisation results for photo-Fenton (Fe) in the baseline scenario.

Impact category	Units	Total	H <sub>2</sub> O <sub>2</sub>	Electricity	FeSO <sub>4</sub>	Transport
ODP	kg eq. CFC-11	1.57E-06	5.17E-08	1.51E-06	6.48E-10	8.69E-09
GWP	kg eq. CO <sub>2</sub>	3.70E+01	5.56E-01	3.64E+01	1.41E-02	6.51E-02
EC	MJ	8.15E+02	1.11E+01	8.02E+02	3.00E-01	1.07E+00
AP	kg eq. SO <sub>2</sub>	1.89E-01	1.84E-03	1.87E-01	7.86E-05	4.62E-04
EP	kg eq. phosphate	1.01E-02	1.63E-04	9.88E-03	5.21E-06	7.63E-05

Table A.5.3. Characterisation results for heterogeneous photocatalysis and H<sub>2</sub>O<sub>2</sub> (Ti+H<sub>2</sub>O<sub>2</sub>) in the baseline scenario.

Impact category	Units	Total	H <sub>2</sub> O <sub>2</sub>	TiO <sub>2</sub>	Electricity	Transport
ODP	kg eq. CFC-11	2.34E-06	5.17E-08	1.67E-07	2.12E-06	9.18E-09
GWP	kg eq. CO <sub>2</sub>	5.24E+01	5.56E-01	8.80E-01	5.09E+01	6.87E-02
EC	MJ	1.15E+03	1.11E+01	1.75E+01	1.12E+03	1.13E+00
AP	kg eq. SO <sub>2</sub>	2.71E-01	1.84E-03	6.96E-03	2.61E-01	4.88E-04
EP	kg eq. phosphate	1.45E-02	1.63E-04	4.69E-04	1.38E-02	8.06E-05

Table A.5.4. Characterisation results for heterogeneous photocatalysis and photo-Fenton (Ti+Fe) in the baseline scenario.

Impact category	Units	Total	H <sub>2</sub> O <sub>2</sub>	TiO <sub>2</sub>	Electricity	FeSO <sub>4</sub>	Transport
ODP	kg eq. CFC-11	8.33E-07	5.17E-08	1.67E-07	6.05E-07	6.48E-11	9.23E-09
GWP	kg eq. CO <sub>2</sub>	1.61E+01	5.56E-01	8.80E-01	1.45E+01	1.41E-03	6.91E-02
EC	MJ	3.51E+02	1.11E+01	1.75E+01	3.21E+02	3.00E-02	1.13E+00
AP	kg eq. SO <sub>2</sub>	8.40E-02	1.84E-03	6.96E-03	7.47E-02	7.86E-06	4.91E-04
EP	kg eq. phosphate	4.66E-03	1.63E-04	4.69E-04	3.95E-03	5.21E-07	8.11E-05

Table A.5.5. Characterisation results for ozonation (O3) in the baseline scenario.

Impact category	Units	Total	O <sub>2</sub>	Electricity	Transport
ODP	kg eq. CFC-11	2.04E-05	6.28E-06	1.21E-05	1.99E-06
GWP	kg eq. CO <sub>2</sub>	4.57E+02	1.51E+02	2.91E+02	1.49E+01
EC	MJ	9.99E+03	3.33E+03	6.42E+03	2.44E+02
AP	kg eq. SO <sub>2</sub>	2.38E+00	7.75E-01	1.49E+00	1.06E-01
EP	kg eq. phosphate	1.38E-01	4.11E-02	7.90E-02	1.75E-02

Table A.5.6. Characterisation results for ozonation and UVA (O3+UVA) in the baseline scenario.

Impact category	Units	Total	O <sub>2</sub>	Electricity	Transport
ODP	kg eq. CFC-11	1.05E-05	3.15E-06	6.35E-06	9.98E-07
GWP	kg eq. CO <sub>2</sub>	2.36E+02	7.57E+01	1.53E+02	7.48E+00
EC	MJ	5.16E+03	1.67E+03	3.37E+03	1.23E+02
AP	kg eq. SO <sub>2</sub>	1.23E+00	3.89E-01	7.84E-01	5.31E-02
EP	kg eq. phosphate	7.08E-02	2.06E-02	4.15E-02	8.77E-03

Table A.5.7. Characterisation results for heterogenous photocatalysis (Ti) in the solar scenario.

Impact category	Units	Total	TiO <sub>2</sub>	Transport
ODP	kg eq. CFC-11	1.68E-07	1.67E-07	9.84E-10
GWP	kg eq. CO <sub>2</sub>	8.88E-01	8.80E-01	7.37E-03
EC	MJ	1.76E+01	1.75E+01	1.21E-01
AP	kg eq. SO <sub>2</sub>	7.01E-03	6.96E-03	5.23E-05
EP	kg eq. phosphate	4.77E-04	4.69E-04	8.64E-06

Table A.5.8. Characterisation results for photo-Fenton (Fe) in the solar scenario.

Impact category	Units	Total	H <sub>2</sub> O <sub>2</sub>	FeSO <sub>4</sub>	Transport
ODP	kg eq. CFC-11	6.10E-08	5.17E-08	6.48E-10	8.69E-09
GWP	kg eq. CO <sub>2</sub>	6.35E-01	5.56E-01	1.41E-02	6.51E-02
EC	MJ	1.25E+01	1.11E+01	3.00E-01	1.07E+00
AP	kg eq. SO <sub>2</sub>	2.38E-03	1.84E-03	7.86E-05	4.62E-04
EP	kg eq. phosphate	2.44E-04	1.63E-04	5.21E-06	7.63E-05

Table A.5.9. Characterisation results for heterogeneous photocatalysis and H2O2 (Ti+H2O2) in the solar scenario.

Impact category	Units	Total	H <sub>2</sub> O <sub>2</sub>	TiO <sub>2</sub>	Transport
ODP	kg eq. CFC-11	2.28E-07	5.17E-08	1.67E-07	9.18E-09
GWP	kg eq. CO <sub>2</sub>	1.50E+00	5.56E-01	8.80E-01	6.87E-02
EC	MJ	2.97E+01	1.11E+01	1.75E+01	1.13E+00
AP	kg eq. SO <sub>2</sub>	9.28E-03	1.84E-03	6.96E-03	4.88E-04
EP	kg eq. phosphate	7.12E-04	1.63E-04	4.69E-04	8.06E-05

Table A.5.10. Characterisation results for heterogeneous photocatalysis and photo-Fenton (Ti+Fe) in the solar scenario.

Impact category	Units	Total	H <sub>2</sub> O <sub>2</sub>	TiO <sub>2</sub>	FeSO <sub>4</sub>	Transport
ODP	kg eq. CFC-11	2.28E-07	5.17E-08	1.67E-07	6.48E-11	9.23E-09
GWP	kg eq. CO <sub>2</sub>	1.51E+00	5.56E-01	8.80E-01	1.41E-03	6.91E-02
EC	MJ	2.97E+01	1.11E+01	1.75E+01	3.00E-02	1.13E+00
AP	kg eq. SO <sub>2</sub>	9.29E-03	1.84E-03	6.96E-03	7.86E-06	4.91E-04
EP	kg eq. phosphate	7.13E-04	1.63E-04	4.69E-04	5.21E-07	8.11E-05

Table A.5.11. Characterisation results for heterogeneous photocatalysis (Ti) in the solar scenario, changing the functional unit.

Impact category	Units	Total	TiO <sub>2</sub>	Transport
ODP	kg eq. CFC-11	2.54E-06	2.53E-06	1.49E-08
GWP	kg eq. CO <sub>2</sub>	1.34E+01	1.33E+01	1.11E-01
EC	MJ	2.66E+02	2.64E+02	1.82E+00
AP	kg eq. SO <sub>2</sub>	1.06E-01	1.05E-01	7.91E-04
EP	kg eq. phosphate	7.21E-03	7.08E-03	1.31E-04

Table A.5.12. Characterisation results for photo-Fenton (Fe) in the solar scenario, changing the functional unit.

Impact category	Units	Total	H <sub>2</sub> O <sub>2</sub>	FeSO <sub>4</sub>	Transport
ODP	kg eq. CFC-11	4.63E-07	3.93E-07	4.86E-09	6.60E-08
GWP	kg eq. CO <sub>2</sub>	4.82E+00	4.22E+00	1.06E-01	4.94E-01
EC	MJ	9.47E+01	8.44E+01	2.25E+00	8.10E+00
AP	kg eq. SO <sub>2</sub>	1.81E-02	1.40E-02	5.90E-04	3.51E-03
EP	kg eq. phosphate	1.86E-03	1.24E-03	3.91E-05	5.80E-04

Table A.5.13. Characterisation results for heterogeneous photocatalysis and H<sub>2</sub>O<sub>2</sub> (Ti+H<sub>2</sub>O<sub>2</sub>) in the solar scenario, changing the functional unit.

Impact category	Units	Total	H <sub>2</sub> O <sub>2</sub>	TiO <sub>2</sub>	Transport
ODP	kg eq. CFC-11	2.46E-06	5.58E-07	1.80E-06	9.91E-08
GWP	kg eq. CO <sub>2</sub>	1.62E+01	6.00E+00	9.50E+00	7.42E-01
EC	MJ	3.21E+02	1.20E+02	1.88E+02	1.22E+01
AP	kg eq. SO <sub>2</sub>	1.00E-01	1.98E-02	7.51E-02	5.27E-03
EP	kg eq. phosphate	7.69E-03	1.76E-03	5.06E-03	8.71E-04

Table A.5.14. Characterisation results for heterogeneous photocatalysis and photo-Fenton (Ti+Fe) in the solar scenario, changing the functional unit.

Impact category	Units	Total	H <sub>2</sub> O <sub>2</sub>	TiO <sub>2</sub>	FeSO <sub>4</sub>	Transport
ODP	kg eq. CFC-11	1.72E-06	3.90E-07	1.26E-06	4.86E-10	6.98E-08
GWP	kg eq. CO <sub>2</sub>	1.14E+01	4.20E+00	6.65E+00	1.06E-02	5.22E-01
EC	MJ	2.25E+02	8.39E+01	1.32E+02	2.25E-01	8.56E+00
AP	kg eq. SO <sub>2</sub>	7.02E-02	1.39E-02	5.26E-02	5.90E-05	3.71E-03
EP	kg eq. phosphate	5.39E-03	1.23E-03	3.54E-03	3.91E-06	6.13E-04

## Normalisation and weighting

The following table include, for each treatment and scenario, the results of normalisation. The normalised impact indicators are then summed up for each treatment in the last row, leading to the weighted score. Since the normalisation results are only summed, all impact categories are equally weighted with a factor of 1.

Table A.5.15. Normalised and weighted results for all treatments in the baseline and solar scenarios.

Impact category	Units	Ti (lamp)	Ti (solar)	Ti+H2O2 (lamp)	Ti+H2O2 (solar)	Fe (lamp)	Fe (solar)	Ti+Fe (lamp)	Ti+Fe (solar)	O3	O3+UVA
ODP	y	4.57E-14	2.03E-15	2.83E-14	2.75E-15	1.90E-14	7.35E-16	1.00E-14	2.75E-15	2.45E-13	1.26E-13
GWP	y	1.83E-11	1.84E-13	1.09E-11	3.12E-13	7.68E-12	1.32E-13	3.33E-12	3.13E-13	9.48E-11	4.89E-11
EC	y	6.84E-11	6.19E-13	4.06E-11	1.05E-12	2.87E-11	4.39E-13	1.23E-11	1.05E-12	3.52E-10	1.82E-10
AP	y	1.55E-11	2.38E-13	9.21E-12	3.16E-13	6.43E-12	8.08E-14	2.86E-12	3.16E-13	8.08E-11	4.17E-11
EP	y	1.93E-11	3.82E-13	1.16E-11	5.70E-13	8.10E-12	1.96E-13	3.73E-12	5.70E-13	1.10E-10	5.67E-11
<b>Total</b>	<b>y</b>	<b>1.22E-10</b>	<b>1.43E-12</b>	<b>7.23E-11</b>	<b>2.25E-12</b>	<b>5.09E-11</b>	<b>8.48E-13</b>	<b>2.23E-11</b>	<b>2.25E-12</b>	<b>6.38E-10</b>	<b>3.29E-10</b>

# CHAPTER 6.

## Life Cycle and Cost Assessment of a Coupled Advanced Oxidation-Biological Process for Wastewater Treatment

---

*“Following the light of the sun, we left the old world”*

*Christopher Columbus*

### CONTENTS

6.1. The CADOX Project .....	137
6.1.1. Objectives and project consortium .....	138
6.1.2. Project workplan .....	139
6.1.3. Pilot plants .....	140
6.1.4. Demonstration plant .....	141
6.1.5. Contribution of this thesis to the CADOX project .....	143
6.2. Goal and Scope .....	144
6.2.1. Goal .....	144
6.2.2. Coverage of the study .....	144
6.2.2.1. Temporal coverage .....	144
6.2.2.2. Geographical coverage .....	145
6.2.2.3. Technology coverage .....	145
6.2.2.4. Level of sophistication .....	145
6.2.2.5. Type of analysis: descriptive and change oriented .....	145
6.2.3. Baseline alternatives under study .....	145
6.2.4. Wastewater to treat .....	146
6.2.5. Experimental work .....	147
6.2.5.1. Treatment of Femac in the pilot plants .....	147
6.2.5.2. Adsorption of Femac in activated carbon .....	148
6.2.6. Scenario conditions .....	151
6.2.6.1. Location of the plant .....	151
6.2.6.2. Plant capacity .....	152
6.2.6.3. Coupling to biological treatment .....	152
6.2.6.4. Management of spent catalysts: iron and titanium dioxide .....	153
6.2.6.5. Management of spent activated carbon .....	154
6.2.7. Function and functional unit .....	155
6.2.8. System description and boundaries .....	155

6.2.8.1. Background and foreground system.....	157
6.2.8.2. Boundaries between the economy and the environment.....	157
6.2.8.3. Cut-off rules.....	157
6.2.8.4. Allocation.....	157
6.2.9. Other hypothesis.....	158
6.2.9.1. Plant lifetime.....	158
6.2.9.2. Mode of operation.....	158
6.2.9.3. Overdimensioning.....	159
6.2.9.4. Lamp irradiation.....	159
6.2.9.5. Transports.....	159
6.2.10. Data collection.....	160
6.2.11. Life Cycle Impact Assessment methodology.....	161
6.2.11.1. Selection of impact categories, classification and characterisation.....	161
6.2.11.2. Normalisation and weighting.....	163
6.3. Inventory Analysis for Baseline Alternatives.....	164
6.3.1. DOC to be removed in order to achieve biodegradability.....	164
6.3.2. Infrastructure for solar-based photocatalytic plants.....	164
6.3.2.1. Inventory for CPC infrastructure.....	164
6.3.2.2. Calculation of CPC area.....	165
6.3.3. Electricity.....	166
6.3.3.1. Pumping.....	166
6.3.3.2. Ozoniser.....	167
6.3.3.3. Lamps.....	167
6.3.3.4. Microfiltration.....	168
6.3.3.5. Stirring.....	169
6.3.3.6. Overall consumption.....	169
6.3.4. Chemicals and ancillary materials.....	169
6.3.4.1. Oxygen.....	169
6.3.4.2. Hydrogen peroxide.....	170
6.3.4.3. Ferrous sulphate.....	170
6.3.4.4. Titanium dioxide.....	170
6.3.4.5. Sulphuric acid.....	170
6.3.4.6. Sodium hydroxide.....	170
6.3.4.7. Activated carbon.....	170
6.3.4.8. UV Lamps.....	171
6.3.4.9. Water.....	172
6.3.4.10. Transport of materials to the plant.....	172
6.3.5. Solid waste management.....	173
6.3.5.1. Landfilling of spent catalysts.....	173
6.3.5.2. Regeneration of spent activated carbon.....	174
6.3.6. Process emissions.....	175
6.3.7. Land use.....	176
6.3.8. Municipal Wastewater Treatment Plant.....	176
6.3.9. Summary tables.....	177
6.4. Life Cycle Impact Assessment for Baseline Alternatives.....	182
6.4.1. Contribution analysis.....	182
6.4.1.1. Solar-driven photo-Fenton.....	182
6.4.1.2. Solar-driven heterogeneous photocatalysis.....	183
6.4.1.3. Ozonation.....	183
6.4.1.4. Lamp driven photo-Fenton.....	184
6.4.1.5. Activated carbon adsorption.....	185
6.4.2. Comparative assessment.....	185
6.5. Sensitivity Analysis on Activated Carbon Production and Regeneration.....	187
6.5.1. Inventory analysis.....	187



6.5.1.1. GAC production .....	187
6.5.1.2. Activated carbon regeneration.....	188
6.5.1.3. Summary table .....	189
6.5.2. Life Cycle Impact Assessment .....	190
6.5.2.1. Contribution analysis .....	190
6.5.2.2. Comparative assessment.....	190
6.6. Environmental Impact of Solar Photocatalysis as a Function of UV Light Available .....	192
6.6.1. Environmental implications of lower UV available .....	192
6.6.2. Inventory analysis.....	192
6.6.3. Estimation of solar UV resources in several european locations.....	194
6.6.4. Life Cycle Impact Assessment .....	195
6.7. Assessment of Measures for Environmental Improvement.....	196
6.7.1. Solar-driven photo-Fenton.....	196
6.7.1.1. Measures to be taken .....	196
6.7.1.2. Inventory analysis.....	196
6.7.2. Ozonation.....	198
6.7.2.1. Measures to be taken .....	198
6.7.2.2. Inventory analysis.....	199
6.7.3. Summary table .....	200
6.7.4. Life Cycle Impact Assessment results.....	202
6.7.4.1. Solar-driven photo-Fenton.....	202
6.7.4.2. Ozonation .....	203
6.8. Cost Assessment .....	205
6.8.1. Costing methodology.....	205
6.8.2. Calculation of investment costs.....	206
6.8.2.1. Solar driven AOPs.....	206
6.8.2.2. Ozonation .....	207
6.8.2.3. Lamp-driven photo-Fenton .....	207
6.8.2.4. Activated carbon adsorption .....	207
6.8.3. Calculation of operation costs .....	208
6.8.4. Results of the cost assessment.....	210
6.8.5. Cost of solar photocatalysis as a function of UV light available.....	211
6.8.6. Influence of measures for environmental improvement on costs .....	213
6.8.6.1. Solar driven photo-Fenton .....	213
6.8.6.2. Ozonation .....	215
6.9. Integration of Environmental Impact and Cost .....	216
6.9.1. Definition of an Eco-efficiency Index .....	216
6.9.2. Application of the Eco-efficiency Index to the alternatives under study.....	217
6.10. Conclusions and Recommendations.....	220
6.10.1. Performance of the treatments developed in the CADOX project .....	220
6.10.2. Performance of solar-driven AOPs as compared to lamp-driven AOPs.....	220
6.10.3. Performance of the CADOX technology as compared to conventional technologies.....	221
6.10.4. Processes contributing in a significant manner to the life cycle.....	221
6.10.5. Influence of UV radiation available on solar AOPs performance.....	222
6.10.6. Measures for environmental improvement and their consequences on cost.....	223
6.10.7. Integrated environmental-cost assessment.....	223
6.10.8. Final ranking of alternatives .....	224
6.10.9. Recommendations and outlook.....	226
List of symbols .....	227
References to Chapter 6 .....	229
Appendix 1. Calculation of $Q_{UV}$ from pilot plant data .....	235

Appendix 2. Photovoltaic installation in a solar photocatalytic plant for wastewater treatment .....	237
Appendix 3. Estimation of solar photocatalytic plant dismantling cost .....	240
Appendix 4. Life Cycle Impact Assessment tables.....	242

We have seen in Chapter 5 that an environmental assessment of chemical processes by means of LCA is possible, even when the only data available are those generated in the laboratory. Obviously, such a preliminary assessment allows for screening purposes and to highlight critical features, rather than to draw categorical conclusions. In the present chapter we make a step ahead in our environmental and economic assessment of AOPs, since several techniques evaluated at the laboratory scale in Chapter 5 are once again evaluated, but this time data derived mainly from pilot and full-scale plants are used, permitting a more precise and complete study, which is interesting for several reasons: first, as has been said, AOPs are evaluated more accurately and closer to real work conditions; second, this accuracy allows to compare AOPs with conventional technologies already applied to full scale, as is the case of activated carbon adsorption. Another reason is that measures for environmental improvement can be suggested in more detail, as the object of analysis (the wastewater treatment plant, WWTP) is already designed or even physically exists. Finally, the results of this study can serve either to validate or to refute the conclusions of the screening carried out in Chapter 5, therefore providing arguments to discuss whether LCA as a tool is reliable or not, depending on the level of technology development.

The structure of this chapter is similar to that of the previous one. First of all, the CADOX project, in the framework of which this case study has been included, is presented. Next, the LCA and LCC are carried out and finally environmental and economic data are integrated and discussed.

## 6.1. The CADOX Project

Protection of the European water bodies from contamination has undergone a remarkable progress since the first Directive was approved in 1975 (EU 1975). Nevertheless, severe pressure remains from the so-called Priority Hazardous Substances (PHSs), which have been identified and listed by the EU in recent years (EU 2001). Certainly, humans and natural ecosystems are threatened by pesticides, heavy metals, hydrocarbons, etc., dissolved in wastewater coming mainly from industrial activities, in which these substances are dissolved at low or medium concentrations ( $<500 \text{ mg l}^{-1}$ ). On the other hand, the IPPC Directive (EU 1996) requires the development of technologies and management practices for pollution prevention in several industrial sectors, but due to lack of available on-site treatment technologies, a large number of these industrial activities do not treat their wastewaters properly.

The CADOX<sup>4</sup> research project (Malato and Maldonado 2004), funded by the European Commission's Fifth Framework Programme, addresses this need for simple and yet low-cost technologies for remediation of industrial wastewaters, focusing on a particular group of PHSs, namely NBCs, biocides and plant protection products. The starting point of the project is that this technological gap can be filled by the development of a technology based on the coupling of AOPs with conventional biological treatment (figure 6.1.).

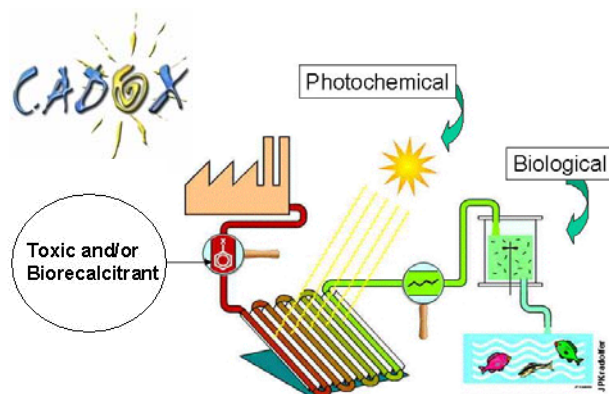

Figure 6.1. The CADOX concept.

The potential of AOPs for treatment of industrial wastewaters containing PHSs is widely recognized, but it is also known that achieving complete mineralization of these pollutants implies higher costs as compared to biological treatment. On the other hand, biological treatment alone is not effective in treating such wastewaters, due to the fact that PHSs cause either toxicity or inhibition to microorganisms. However, the use of AOPs as a pre-treatment to obtain biodegradable wastewaters can be justified if the microorganisms in a subsequent bioreactor are able to degrade the intermediates resulting from the advanced oxidation step. Therefore, the coupling of AOPs and biodegradation is a promising technology that could substantially reduce the cost of treating PHS-containing wastewaters.

<sup>4</sup> A Coupled Advanced Oxidation-Biological Process for Recycling of Industrial Wastewater Containing Persistent Organic Contaminants. Contract n° EVK1-CT-2002-00122. [www.psa.es/webeng/projects/cadox/index.html](http://www.psa.es/webeng/projects/cadox/index.html)

### 6.1.1. Objectives and project consortium

The ultimate goal of the CADOX project is to develop a commercial closed-loop hybrid technology based on AOPs and biological processes for the remediation of industrial wastewater polluted by organic contaminants (Malato and Maldonado 2004). This goal can be split in several scientific and technological objectives, which are listed below.

The scientific objectives are:

- To demonstrate that the AOPs heterogeneous photocatalysis, photo-Fenton, and ozonation, coupled with biodegradation constitute a suitable procedure for decontaminating 7 medium-to-highly soluble pesticides (Alachlor, Atrazine, Chlorphenvinfos, Diuron, Isoproturon, Lindane and Pentachlorophenol) and 3 NBCS (Dichloroethane, Dichloromethane and Chloroform), as well as other pesticides and NBCS as function of the final users (Janssen and Deretil).
- To define the best combination for coupling treatments.
- To design new solar collectors for carrying out TiO<sub>2</sub> and photo-Fenton photocatalysis.
- To construct and test 2 small prototypes employing combinations of the above mentioned technologies.

The technological objectives are:

- To construct and test a demonstration treatment plant for effluents containing toxic and biorecalcitrant compounds, based on the results of the 2 prototypes.
- Conceptual design and economic evaluation of a full size treatment plant.
- Detailed analysis of the applicability of this technology by determining low-to-medium concentration (<500 mg/l) sources of PHSs in Europe.

The main deliverable for exploitation will be the “CADOX Technology Handbook”. This handbook is expected to assist in marketing the technology developed in the project, and will act as a matrix, indicating the best combination for the most effective treatment.

The project is scheduled to last 3.5 years (started in february 2003) with the participation of 9 industrial operators and science and technology developers from 5 EU countries (table 6.1). The general coordinator of the project is the Plataforma Solar de Almería – CIEMAT<sup>5</sup>, a national research centre qualified as a European Large Scientific Installation, fully oriented to international collaboration and clearly positioned as a bridge between basic research and industrial applications.

---

<sup>5</sup> [www.psa.es](http://www.psa.es)

Table 6.1. CADOX consortium

Name	Country	Business activity/main mission	Role in the project
Plataforma Solar de Almería, CIEMAT	Spain	Technological research in energy and environment. Design, operation and evaluation of solar systems	Solar system design, testing and evaluation. Solar water treatment know-how. Project coordination and management
Ecosystem Environmental Services	Spain	Engineering. Turnkey treatment plants, marketing and plant installation	Plant specifications and engineering analysis. Demonstration plant erection and set-up
Ao Sol, Energias Renováveis	Portugal	Manufacturer of solar collectors, solar system engineering and installation	Solar collector design and optimisation. Construction of solar collectors for prototypes and demonstration Plants
Universitat Autònoma de Barcelona (UAB)	Spain	Research, expertise in photocatalysts and ozone. Public university	TiO <sub>2</sub> process optimisation and O <sub>3</sub> treatment. Basic research and modelling. Environmental assessment.
Instituto Nacional de Engenharia e Tecnologia Industrial (INETI)	Portugal	Engineering and technology research institute. Development of renewable energy processes and applications	Solar collector development for TiO <sub>2</sub> and photo-Fenton applications. Prototype testing
Trailigaz Compagnie Générale de l'Ozone	France	Manufacturer of ozone systems	Ozone system optimisation/ of Ozone components supplier
Janssen Pharmaceutica	Belgium	Agrochemical and pharmaceutical product manufacturer	Technology evaluator. Assessment of project results exploitation. Final user (IPPC Directive Annex 1 Category 4.4)
École Polytechnique Fédérale de Lausanne (EPFL)	Switzerland	Research in biological treatment processes coupled with physical-chemical treatment. Public university	Photo-Fenton photocatalytic process and coupled AOPs biological reactor optimisation. Biodegradability and toxicity analysis
DSM Deretil	Spain	Chemical company with effluents containing NBCS	Beneficiary of Demonstration plant. Final user (IPPC directive Category 4.5 of Annex 1)

### 6.1.2. Project workplan

In order to assure an adequate project structure, the scientific and technical workplan consists of 8 workpackages, distributed in two main stages of the project: the research phase and the demonstration phase. each workpackage is divided into several tasks with specific milestones, and is carried out under the leading of a project partner. The list of workpackages and their aim is summarized in table 6.2.

Workpackage 3 along with its internal reports is specially important for performing this case study. This is due to the fact that this workpackage deals with construction and testing of two small pilot plants, which are described in the next section. The experimental data obtained during testing of these plants with synthetic wastewaters, constitutes the main source of information for the environmental and economic assessment developed in this chapter.

Table 6.2. CADOX project workpackage list.

Workpackage N°	Title	Lead partner	Duration (months)		Aim
			Start	End	
Research phase					
1	Scientific research	UAB	0	36	Selection of the target compounds to be used during the research phase of the project and establishing the best conditions for treating these compounds.
2	Engineering and technology development	CIEMAT	2	9	Development of solar collectors and catalyst separation technology for TiO <sub>2</sub> and photo-Fenton processes.
3	Prototype construction and testing	INETI	10	18	Construction, testing and evaluation of two small plants based on TiO <sub>2</sub> and photo-Fenton (setting of experimentation and analytical procedures, treatment time, biocompatibility of by-products in biological treatment, among other elements).
4	Pilot plant design	ECOSYSTEM	17	24	Design of a demonstration plant based on the previous developments. Includes selecting the best method for treatment, up-scaling and detailed engineering.
5	Project management	CIEMAT	0	24	Tasks related to project coordination: elaboration of reports, cost statements and other administrative tasks, creation and maintenance of a web page and project results dissemination.
Demonstration phase					
6	Technological demonstration and assessment	DERETIL	25	33	Covers the construction and testing at the demonstration site (DERETIL) of a plant based on combining AOPs and biotreatment
7	Environmental and social aspects	EPFL	25	33	Analysis of social, employment, and environmental aspects of the project. This WP will also include an analysis of UV power available in Europe in order to assess where the solar technology can be applied.
8	Project results exploitation and management	CIEMAT	25	33	Elaboration of final project reports and determination of the feasibility of future commercialization of the technology.

### 6.1.3. Pilot plants

The last step of Workpackage 2 was the integration and design of TiO<sub>2</sub>-based and photo-Fenton based prototype units (figure 6.2.). The TiO<sub>2</sub> unit (Passarinho and Farinha 2005) was installed at INETI, while the photo-Fenton unit was installed at PSA (Maldonado et al. 2004). They were designed for 4 m<sup>2</sup> of Compound Parabolic Collectors (CPCs) and 80 litres of process volume. Both prototypes are composed of: solar reactor, biological reactor, ozone generator and ozone contact column, control and electric board, supporting structure and technical features. The CPCs are composed of low-iron borosilicate glass tubes having an outer diameter of 50 mm, and the reflectors are built in anodised aluminium. On-line measurement and registration of temperature, pH, ORP and dissolved oxygen are installed. The ozone system has a maximum capacity of 20 g O<sub>3</sub>/hour, and the contact column has the following characteristics: 190 mm internal diameter, height of 1800 mm, effluent flow of 1 m<sup>3</sup>/hour, total water volume 56.5 litres and a contact time of 220 seconds. The biological reactor works with fixed biomass. The neutralisation tank has a volume of 150 litres and collects the effluent from the advanced oxidation. After neutralisation it is transferred to the conditioning tank (100 litres), where fine pH and nutrient adjustment takes place. The bioreactor (100 litres) contains the biomass, grown on pall rings. Each batch load from the advanced oxidation is recirculated between these two tanks until desired effluent quality is achieved; at this point, water is transferred to the settling tank (100 litres) before discharge.



Figure 6.2. Images of the CADOX pilot plants installed at INETI and PSA.

#### 6.1.4. Demonstration plant

The CADOX project culminates with the erection and testing of a demonstration plant applying the hybrid technology developed in the research phase of the project. In february 2006, the plant was finally built and ready for set-up and testing. The final user of the plant is DSM Deretil, a project partner the facilities of which are located in Villaricos (Almería, Spain). Wastewaters generated by Deretil are characterised by specific effluents with variable biodegradability, high concentration of salts due to the use of sea water in production processes, and high nitrogen concentrations. Currently these wastewaters are treated by a biological process applying nitrification-denitrification. The wastewater to be treated in the demonstration plant corresponds to the final effluent of the current biological plant, after dissolving 500 mg l<sup>-1</sup> of Femac, a product under development by Deretil which is non-biodegradable (see section 6.2.4). As a consequence, the demonstration plant will treat a non-biodegradable substance dissolved in a hardly biodegradable wastewater.

Figure 6.3 shows an overview of the different elements of the demonstration plant, while in figure 6.4. a simplified flow diagram is displayed. The plant consists basically of three units: the solar-driven photo-Fenton unit, the ozonation unit, and the biological unit. Photo-Fenton and ozonation have been the techniques selected for advanced oxidation due to their favourable performance in the laboratory and pilot plant tests as compared to heterogeneous photocatalysis. Both photo-Fenton and ozonation are coupled to the biological unit, although the oxidation step must alternatively use one technique or the other, as they are not coupled to each other. The purpose is to compare these two feasible treatment options at industrial scale, specially in economic terms.



Figure 6.3. Images of the CADOX demonstration plant installed in DSM Deretil.

The most important feature of the photo-Fenton unit is the CPC field, consisting of 3 arrays of 15 collectors each. The total aperture area is 100 m<sup>2</sup> and the volume is 1.17 m<sup>3</sup> of borosilicate glass tubes. The wastewater is pumped from the preparation tank to the 3 m<sup>3</sup> buffer tank, where pH is adjusted and chemicals (iron sulphate, hydrogen peroxide) added. The reactor works in batch mode, and has been designed to treat 2 m<sup>3</sup> in two days, assuming 7 sunlight hours/day, although tests will be carried out in order to optimize treatment time. Once the oxidation step is complete, the wastewater is pumped to the neutralization tank, where pH is risen to 7, causing the iron catalyst to precipitate and settle. At this point the water enters the biological treatment.

The ozonation unit is constituted a by a Trailgaz ozonisator fed with pure oxygen, which is able to produce 1 kg h<sup>-1</sup> ozone, at a concentration of 160 g Nm<sup>-3</sup>. The reactor is composed of two stainless-steel contact columns connected in series, including an ozone recirculation system to maximize gas-liquid transfer efficiency (see section 6.7.2 for details). This ozonation unit is designed to work in batch mode, treating 1 m<sup>3</sup> wastewater in 8-10 hours. After the oxidation step, the water is pumped to the neutralization tank, prior to entering the biological reactor.



The biological system is composed by a 5 m<sup>3</sup> neutralization tank, a 2 m<sup>3</sup> conditioning tank and an aerobic upflow immobilized biomass reactor (IBR) containing 1 m<sup>3</sup> polypropylene pall rings. This system works in semi-continuous mode: the batches from either ozonisation or photo-Fenton oxidation are neutralized and progressively pumped to the conditioning tank, which is connected to the IBR in a recirculation flow. The effluent from the IBR is finally discharged.

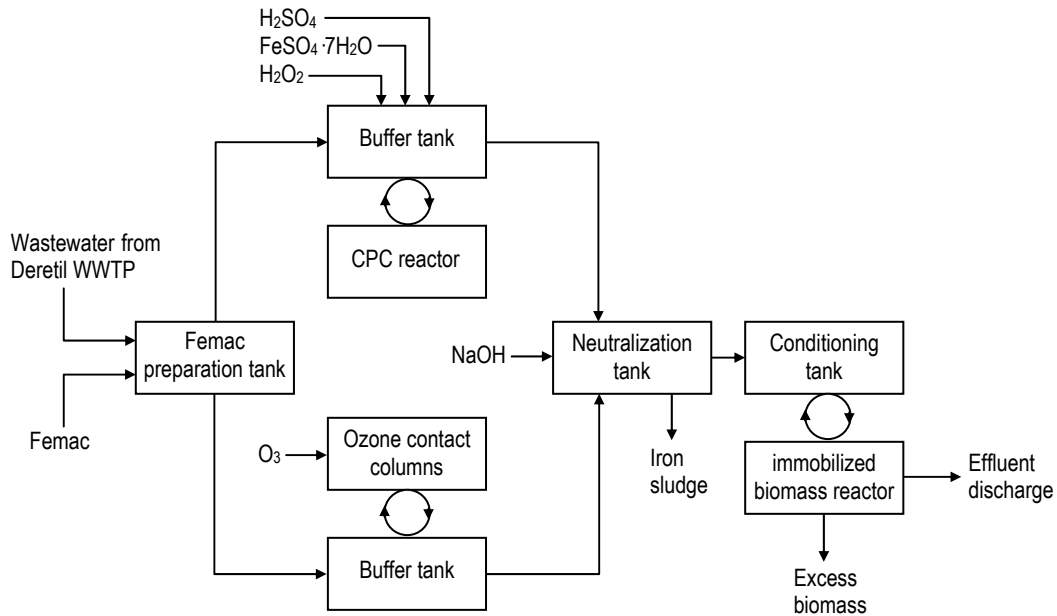

Figure 6.4. Simplified flow diagram of the CADOX demonstration plant installed in DSM Deretil.

### 6.1.5. Contribution of this thesis to the CADOX project

The study described in this chapter of the thesis is included in the Demonstration phase of the CADOX project. Workpackage 7, dealing with environmental and social aspects of the project, comprises Task 710 titled “Analysis of current treatments and environmental costs”, being the final step the realization of a LCA. Nevertheless, this study also contributes to Workpackage 6, dealing with technological demonstration and assessment; task 630, titled “Technology up-scaling. Cost-benefit analysis”, aims at performing a cost estimation of the CADOX plants and a cost and environmental comparison of using lamps instead of solar energy, as well as an evaluation of competing technologies.

## 6.2. Goal and Scope

According to the ISO standards, the goal and scope of the study must be clearly defined. This implies to clearly state the purpose and the intention for carrying out the LCA, as well as defining the system boundaries, the function of the system and functional unit, data requirements and main hypotheses, among others (ISO 1997, 1998).

### 6.2.1. Goal

The aim of this study is to assess the technology developed by the CADOX project, i.e. the coupling of AOPs with biological treatment for remediation of industrial wastewaters containing PHSs. This general statement can be split in several research questions which are intended to be given an answer, from both the environmental and economic point of view:

- Which of the AOP treatments developed in the CADOX project presents the best performance: solar photo-Fenton, solar TiO<sub>2</sub> photocatalysis or ozonation?
- Which stages or processes contribute in a significant manner to the overall Life-Cycle impact and cost of these technologies?
- How can these technologies be environmentally improved? what would be the economic consequences of these improvements?
- What is the performance of solar AOPs as compared to lamp-driven AOPs?
- How does the availability of solar radiation affect solar-driven AOPs?
- Are the AOP treatments developed by the CADOX project preferable to conventional technologies?
- How can environmental and economic information be integrated in a simple way for decision making?

The main reason to execute this study is the early stage of development of the technology. Besides technical and economic feasibility, the environmental performance of the AOPs must be considered as well, allowing guidelines for improvement to be drawn and incorporated in commercial plants. On the other hand, the comparative environmental assessment allows to determine if the technology being developed goes in the right direction, i.e., causing a lower environmental impact than existing alternatives.

### 6.2.2. Coverage of the study

Under this heading several elements concerning the scope of the LCA study, as suggested by Guinée et al. (2002), are defined.

#### 6.2.2.1. Temporal coverage

The data collected from the CADOX project corresponds to 2004 and 2005, although data for background processes is representative for the situation in year 2000. In principle, the time frame for accounting of environmental impacts is infinite, therefore emissions from the past, present and future are all included in the inventory and integrated without

temporal boundaries (ISO 2000). However, long-term emissions (those taking place in more than 100 years from the present) are specified in the inventory as “long-term”.

#### 6.2.2.2. Geographical coverage

This study pretends to be representative for the EU15. The product system has been modeled always taking into account that the technology for wastewater treatment is applied in a member state. As a consequence, though the LCA has been carried out in Spain, the data and assumptions made are representative for western Europe. The only exception to this is the choice of considering the local solar UV light available in Almeria as baseline condition (see section 6.2.6). Nevertheless, the variability of this parameter will be assessed in detail through a sensitivity analysis. With regard to the LCA database used, most of the data used are representative of Europe or west-european countries<sup>6</sup>. Finally, in accordance with the temporal coverage, environmental impacts are accounted for regardless of where they occur, be it the EU or outside its borders.

#### 6.2.2.3. Technology coverage

AOPs are emerging technologies, and with the exception of ozonation, little data is available on commercial applications. These technologies are covered in the study by the data generated within the CADOX project, mostly at pilot scale. For GAC adsorption, as well as for the general background system, the processes represent in most cases the average of currently used technology in western Europe.

#### 6.2.2.4. Level of sophistication

An LCA can be performed so as to articulate a range of levels of sophistication. These levels are escribed in Guinée et al. (2002). The present study constitutes a detailed LCA in which default methods are used. The ISO guidelines are followed as closely as possible (ISO 14040, 14042, 14042, and 14043), including the recommended sensitivity analysis.

#### 6.2.2.5. Type of analysis: descriptive and change oriented

This LCA describes environmental burdens that may be attributed to a service, i.e. treating wastewaters; at this point the study can be considered of the retrospective or accountancy type (Weidema 2003), aimed at hot-spot identification. However, the aim of this study is also to compare different alternatives as well as to assess the consequences of possible improvements; from this point of view, this can be also considered as a prospective or change-oriented LCA.

### 6.2.3. Baseline alternatives under study

The CADOX project has carried out experimental work with three AOPs coupled to biotreatment, which are studied in detail: photo-Fenton using solar light, TiO<sub>2</sub>-based photocatalysis using solar light, and ozonation. As one of the goals of the study is to compare solar-based to lamp-based AOPs, both photo-Fenton and TiO<sub>2</sub> photocatalysis could be assessed in the lamp scenario. However, in order to minimize the number of treatments, and due to the fact that photo-Fenton has received more attention in the CADOX project (the demonstration plant applies this AOP), only the latter has been considered in the lamp scenario.

---

<sup>6</sup> The Ecoinvent nomenclature include a country or region code for all processes, for example RER for Europe, GLO for global, or CH for Switzerland. These codes tell the geographic representativity of the dataset.

The conventional technology against which the coupled AOPs have been compared, is adsorption by means of Granulated Activated Carbon (GAC), since it is a well established technology to remove toxic pollutants from industrial wastewaters (Becker and Wilson, 1978) and constitutes the most frequent option in the literature when comparisons are made with AOPs (Malato et al. 2001a, 2002; Link and Turchi 1991; Klausner et al. 1992; Nijdam et al. 1999; Hirvonen et al. 1998).

Five wastewater treatment options are then included in the study: two solar AOPs and ozonation, all of them coupled to biotreatment, a lamp based AOP coupled to biotreatment, and carbon adsorption as reference technology. In table 6.3 the acronyms used throughout the study are shown.

Table 6.3. Baseline alternatives included in the LCA and acronyms assigned.

Treatment	Acronym used
Solar Photo-Fenton coupled to biological treatment	Fe (solar)
Solar TiO <sub>2</sub> -based photocatalysis coupled to biological treatment	Ti (solar)
Ozonation coupled to biological treatment	O3
Lamp-based Photo-Fenton coupled to biological treatment	Fe (lamp)
Activated carbon adsorption	GAC

#### 6.2.4. Wastewater to treat

Seven pesticides and three NBCS are the target substances of the CADOX project. Laboratory experiments have been carried out with synthetic wastewaters, at concentrations depending on the respective solubility of the substance. On the other hand, the tests conducted in the pilot plants focused mostly on the following kinds of wastewaters: synthetic mixture of pesticides (Atrazine, Alachlor, Isoproturon, Chlorfenvinphos and Diuron, at a concentration of 10 and 30 mg l<sup>-1</sup> each pesticide) and a synthetic solution of 500 mg l<sup>-1</sup> alfa-methyl-phenylglycine (Femac), a product under development by DSM Deretil and potentially present in its future wastewaters. Finally, also pilot tests were performed with real wastewaters from this company, as it is the final user of the demonstration plant.

The environmental and economic analysis developed in this thesis is based on the pilot plant experiments with synthetic wastewater containing 500 mg l<sup>-1</sup> of Femac, as this is the only wastewater that underwent all the AOPs included in the CADOX project: photo-Fenton, ozonation, TiO<sub>2</sub> photocatalysis, and coupling of these with biotreatment. Therefore, this is the wastewater for which more experimental data is available.

Femac is the commercial name of alfa-methyl-phenylglycine, a product under development by DSM Deretil; it can be potentially used by the company as an intermediate for production of agrochemicals. Table 6.4 shows the chemical structure of the molecule, as well as some physical, chemical and environmental properties. Femac can be shortly described as a highly soluble and non-biodegradable compound which shows little toxicity. The former properties, solubility and non-biodegradability were the main reasons to use this chemical in the coupling tests, as it would allow to detect a biodegradability increase and a relatively high concentration of soluble TOC in the biological reactor.

Table 6.4. Femac data summary.

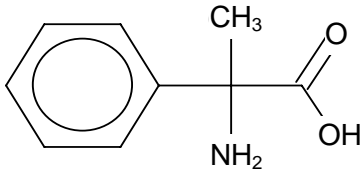
Molecular structure	
	
General data	
Product name	Alfa-methyl-phenylglycine, (S)-2-amino-2-phenylpropionic acid
Empirical formula	C <sub>9</sub> H <sub>11</sub> NO <sub>2</sub>
Molecular weight	165.19
CAS number	13398-26-0
Physical-chemical properties	
Physical state	Solid
Colour	White
Boiling point, melting point	>250-300 °C
Water solubility	33.4 g litre <sup>-1</sup> (20 °C)
Vapour pressure	12.7 ± 0.4 Pa (20 °C)
Octanol-water partition coefficient	log Kow ≤ 1.5 (20 °C)
Environmental data	
Acute toxicity oral, dermal	DL <sub>50</sub> rat > 2000 mg/kg
Chronic toxicity, oral	NOAEL rat > 1000 mg/kg
Ecotoxicity	EC <sub>50</sub> biological wastewater treatment plant > 100 mg litre <sup>-1</sup>
	CL <sub>50</sub> fish (96 hours) > 100 mg litre <sup>-1</sup>
	EC <sub>50</sub> Daphnia Magna (48 hours) > 100 mg litre <sup>-1</sup>
	EC <sub>50</sub> algae (72 hours) > 100 mg litre <sup>-1</sup>
Biodegradability	0%

Source: DSM Deretil.

## 6.2.5. Experimental work

Two kinds of experimental work must be distinguished: testing of AOPs and their coupling, on the one hand, and activated carbon adsorption on the other. The former have been carried out by other researchers in the framework of the CADOX project and data are available from the project reports, while the latter have been performed specifically for this thesis. All these experiments have provided the data on which the LCA has been based. For this reason, an outline of the tests and the results obtained is presented in the following sections.

### 6.2.5.1. Treatment of Femac in the pilot plants

Several tests were performed at INETI and PSA with synthetic wastewaters containing 500 ppm Femac (330 ppm DOC). TiO<sub>2</sub> photocatalysis was carried out at INETI, while ozonation and photo-Fenton tests were put into practice at PSA. The detailed experimental work and results can be found in Passarinho and Farinha (2005) and Maldonado and coworkers (2005a).

In the photo-Fenton experiments, the chemicals used were iron sulphate (FeSO<sub>4</sub>·7H<sub>2</sub>O, Panreac), hydrogen peroxide (reagent grade, 30% w/v, Panreac) and sulphuric acid for pH adjustment (Panreac). First, the wastewater (82 litres) was prepared directly in the reactor by dissolving Femac, with the pump switched on. Then pH was adjusted to 2.7-2.9, the chemicals added (20 ppm iron and 100 ml hydrogen peroxyde) and the collectors uncovered. Solar ultraviolet radiation

was measured by a global UV radiometer, and samples were collected at predetermined times to measure DOC, Femac by liquid chromatography with UV detector (HPLC-UV), ammonia and nitrate by ionic chromatography (LC-IC), iron by ISO 6332 method, and hydrogen peroxide by iodometry. Hydrogen peroxide was determined by periodic analysis and controlled to avoid complete disappearance by adding small amounts as consumed. Temperature was set at 30° C by means of a temperature control system incorporated in the plant.

For ozonisation tests, no pH adjustment was done or any other chemical added. The system was filled with the wastewater (50 litres) and the equipment (pump and ozoniser) switched on. Residual ozone was measured at the outlet of the contact column. Different ozonation intensities were tested: 120 W, 47.7 g O<sub>3</sub> m<sup>-3</sup> (oversaturation of Ozone in the column) and 55 W, 21.9 g O<sub>3</sub> m<sup>-3</sup> (minimisation of Ozone losses in the column). pH was monitored and DOC, anions and ozone consumed were measured periodically. Temperature was not controlled in this case.

In the degradation of Femac by heterogeneous photocatalysis, titanium dioxide (Degussa P25) was used. The wastewater was prepared first as a 3 litres concentrated solution, and afterwards adjusted to the batch volume (78.5 litres) in the reactor. TiO<sub>2</sub> was added (200 ppm) and after 15 min. the collectors were uncovered. Samples were taken at different time intervals, filtered to remove the catalyst and characterised for DOC, COD (Merck kit), ammonia and nitrate (Merck kit). pH and dissolved oxygen in the solution were monitored. Solar UV was also measured by a UV radiometer. Temperature was monitored but not controlled, as this pilot plant was not equipped with temperature control system.

In order to determine the most convenient moment for coupling the AOPs to biological treatment, Zahn-Wellens tests (USEPA 1996) were performed with samples taken at different times. In ozone experiments this test was not performed; instead, the coupling took place when Femac disappeared from solution and only degradation products remained.

For the normal operation of the biological system, the neutralization tank is filled with batches of pre-treated water, where pH is adjusted between 6.5 and 7.5 with H<sub>2</sub>SO<sub>4</sub> and NaOH; nutrients are added by hand. The effluent is pumped to the conditioning tank. A recirculation rate of 200-300 l h<sup>-1</sup> between the conditioner tank and the IBR was used to assure a correct homogenisation, enough residence time in the IBR and to prevent bacteria from being detached from the supports. Mineralization of the effluent was followed by measuring DOC regularly. Dissolved oxygen, redox potential, pH and temperature were also monitored. Nitrification and denitrification reactions were detected by measuring NH<sub>4</sub><sup>+</sup>, NO<sub>3</sub><sup>-</sup>, and NO<sub>2</sub><sup>-</sup> by LC-IC. Also the evolution of the carboxylic acids initially present in the pre-treated effluent were followed by LC-IC.

#### 6.2.5.2. Adsorption of Femac in activated carbon

In order to have reliable data on GAC adsorption of Femac, experimental work was carried out at the Laboratori d'Enginyeria Química i Ambiental (LEQUIA), Universitat de Girona. This work consisted of two steps: first, determination of adsorption isotherms with different commercial carbons, and next continuous testing in a small column using the most appropriate carbon.

An isotherm is the relationship that shows the distribution of adsorbate (adsorbed material) between the adsorbed phase and the solution phase at equilibrium (U.S. Army Corps of Engineers 2001). From an isotherm test, it can be determined whether or not a particular degree of organic removal can be effected, and will show the approximate adsorptive capacity of a given carbon (USEPA 1973). In the isotherm tests, three different carbons were assessed: Calgon Filtrasorb F100, Calgon Filtrasorb F300 and Jacobi Aquasorb 5000. Table 6.5 summarizes the main properties of these activated carbons.

Table 6.5. Specifications of the commercial carbons assessed.

Parameter	Calgon Filtrasorb 300 <sup>a</sup>	Calgon Filtrasorb 100 <sup>a</sup>	Jacobi Aquasorb 5000 <sup>b</sup>
Raw material	Bituminous coal	Bituminous coal	Bituminous coal
Moisture as packed, % weight	2	2	6
Surface area, m <sup>2</sup> g <sup>-1</sup> (BET)	950-1,050	850	1,300
Apparent density, g cm <sup>-3</sup> <sup>c</sup>	0.54	0.60	0.23
Effective size, mm	0.8-1.0	0.8-1.0	N.A.
Uniformity coefficient	2.1	2.1	N.A.
Pore volume, cm <sup>3</sup> g <sup>-1</sup>	0.85	N.A.	1.85
Mean particle diameter, mm	1.5-1.7	1.6	N.A.
Abrasion number, minimum	78	75	N.A.
Iodine number, mg g <sup>-1</sup>	900	850	1,250
Ash, % weight	8	N.A.	12
Sieve size, US standard series			
Larger than No. 8, maximum %	15	15	-
Smaller than No. 30, maximum %	4	4	-
Larger than No. 12, maximum %	-	-	5
Larger than No. 40, maximum %	-	-	3

N.A. Not Available.

Sources:

<sup>a</sup> Calgon Carbon Corporation.

<sup>b</sup> Jacobi Carbons.

<sup>c</sup> Own measurement.



Figure 6.5. Isotherm adsorption batch tests.

First, the carbons were ground, to increase their rate of adsorption. Then 50 ml of 1 g Femac litre<sup>-1</sup> solution was added to Erlenmeyers containing different carbon dosages: 0.05, 0.1, 0.25, 0.5 and 1 g. Also a blank was prepared, containing only the solution and no carbon. According to Eckenfelder (1989), usually a 2-hour contact is enough to achieve greater than 90% of equilibrium; in this case the mixtures were given a contact time of 3 hours with magnetic stirring (figure 6.5) at a temperature of 23 °C, after which they were filtered and DOC was measured by means of a Shimadzu TOC analyzer. The results obtained were adjusted mathematically to the Freundlich isotherm, which is expressed as:

$$\frac{X}{M} = K \cdot C^{1/n} \quad (6.1)$$

Where:

$X$  is the amount of solute adsorbed (mg),

$M$  is the mass of adsorbent (g),

$C$  is the concentration of solute remaining in solution at equilibrium (mg l<sup>-1</sup>),

$K$  and  $n$  are constants that must be determined for each solute, carbon type and temperature.

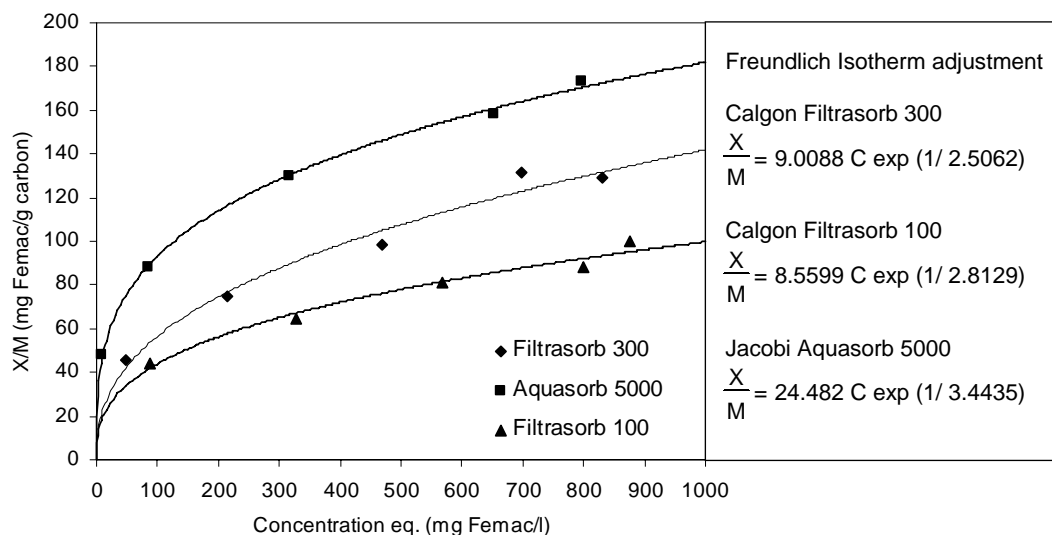

Figure 6.6. Adsorption isotherms of Femac on the commercial carbons tested.

As can be seen in figure 6.5, The maximum X/M ratios were obtained with Jacobi Aquasorb 5000. These isotherms can be used to roughly estimate the carbon dosages required. However, continuous tests provide much more accurate estimates of the performance that can be expected in a full-scale unit. From the results depicted in figure 6.6, the Jacobi carbon was chosen to perform the column test.

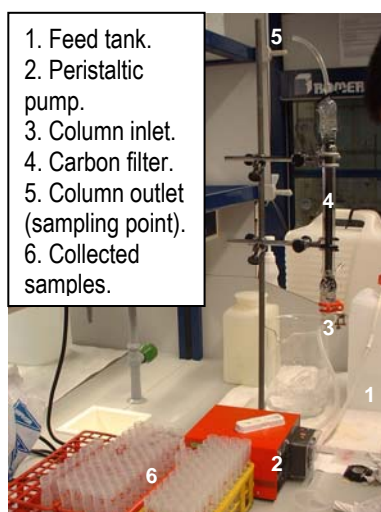

Figure 6.7. Experimental set-up for the continuous activated carbon adsorption test.

The experimental set-up for the continuous test (figure 6.7) consisted basically of a feed tank containing the Femac solution ( $500 \text{ mg l}^{-1}$ ), a peristaltic pump, and a single upflow contact column with the following dimensions: 1.3 cm diameter and 35 cm height. The amount of carbon contained in the bed was 7.41 g. Before starting the test, ultrapure water was pumped through the bed in order to remove carbon fines. Next, the Femac solution was connected to the system and a flow of  $4.67 \text{ ml min}^{-1}$  was set, allowing an Empty Bed Contact Time (EBCT) of 10 minutes. The total duration of the experiment was 11.76 hours (706 minutes); during the first 6 hours samples were collected every 7 minutes, and from this moment until the end of the experiment every 45 minutes. The overall water volume passed



through the bed was 3.3 litres. At this point the inlet and outlet Femac concentration was equivalent ( $500 \text{ mg l}^{-1}$ ), meaning that the carbon bed was saturated. The samples collected were filtered to remove residual carbon particles and DOC was analyzed. The breakthrough curve obtained is plotted in figure 6.8.

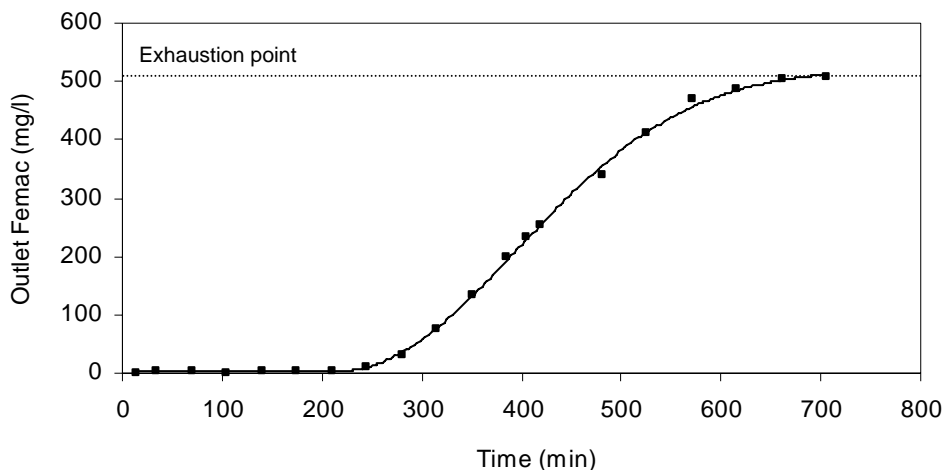

Figure 6.8. Breakthrough curve obtained in the continuous activated carbon adsorption test.

As can be seen, a typical S-shaped curve is obtained. The carbon filter can be considered as a non-steady-state process in which, as carbon becomes saturated, the zone of adsorption moves upwards, with a gradual increase in the effluent concentration, until it is equal to the influent concentration. In this test, the amount of Femac adsorbed was 1.019 g, leading to an average X/M ratio of 138 mg Femac adsorbed per g carbon.

## 6.2.6. Scenario conditions

Several issues are discussed here, concerning the conditions in which the alternatives are assessed: the location of the solar plant, which is related to the amount of solar UV light available, the plant capacity, the type of coupling to biological treatment that has been considered and the management of solid waste.

### 6.2.6.1. Location of the plant

Most of the experiments using solar light have been carried out in Almeria (where PSA is located), a region in southern Europe (figure 6.9) characterised by a high and relatively constant level of solar irradiation. Furthermore, the demonstration plant has also been built in Almeria. For these reasons, in the base case, all solar technologies are assessed in the study according to the local conditions of Almeria, that receives in average  $18.6 \text{ W-UV/m}^2$  (Malato et al. 2001b), including direct and diffuse radiation<sup>7</sup>. Nevertheless, as one of the goals of the study is to find out how these local conditions affect the environmental performance of solar AOPs, a sensitivity analysis will be carried out in which the amount of solar UV light available will be changed.

<sup>7</sup> Direct radiation is the fraction of light that comes "directly" from the sun without alterations, and can be concentrated for example by lenses. On the other hand, diffuse radiation is the fraction of light that is dispersed by elements in the atmosphere such as clouds and arrives to the earth's surface with decreased energy; diffuse radiation can not be concentrated. The solar collectors used in the CADOX project are able to take advantage of direct and diffuse UV light, and therefore both components must be taken into account.

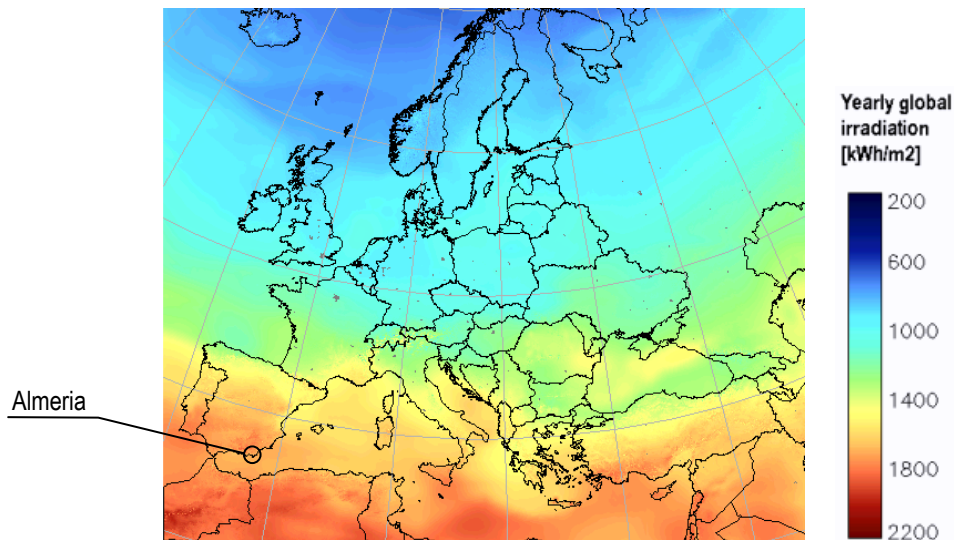

Figure 6.9. Almeria in the european context of solar radiation. Source: EU 2005.

#### 6.2.6.2. Plant capacity

In order to be fully comparable, the AOP techniques as well as GAC adsorption must be assessed as having the same treatment capacity. In the study this capacity has been set for all treatments from the size of the CADOX demonstration plant. According to the engineering specifications (Maldonado et al. 2005b), the plant built in DSM Deretil has 100 m<sup>2</sup> CPC. If synthetic Femac wastewater was to be treated with this solar field area, the capacity would be 6.8 m<sup>3</sup> day<sup>-1</sup> or 2,500 m<sup>3</sup> year<sup>-1</sup>, which is the figure that has been chosen in the study. The detailed calculations that lead to this figure are not shown here, but reported in section 6.3.2.2.

#### 6.2.6.3. Coupling to biological treatment

All the AOPs tested in the CADOX project have been coupled in the pilot plants and in the demonstration plant to a biological treatment with immobilized biomass. The main purpose of this coupling is to demonstrate that the effluent resulting from either solar photocatalysis or ozonation is readily biodegradable by microorganisms, rather than to pretend that in a commercial plant, the AOP must always be coupled to an in-situ biological reactor. In fact, all the effluents assessed in the project have low to medium concentrations of PHSs and once detoxified, they display COD values far below 1500 ppm, hence allowing direct discharge to a public sewer (Generalitat de Catalunya 2003). In such a case, the biological treatment would take place downstream in a typical municipal wastewater treatment plant (MWWTP), together with domestic wastewaters. In-situ coupling, then, would only make sense when an industrial facility has no access to a public sewer, and must comply with the more stringent river-bed emission limits. Discharging to the sewer is also preferable from an environmental risk point of view, since a failure in the industrial wastewater plant can possibly be buffered by the municipal plant, while in the absence of the latter, the aquatic ecosystem could be damaged (Carrera 2005). For these reasons, all treatments have been modelled in the LCA as discharging the effluent to the sewer (including GAC adsorption), and taking into account the environmental burdens related to downstream wastewater treatment in a municipal plant.

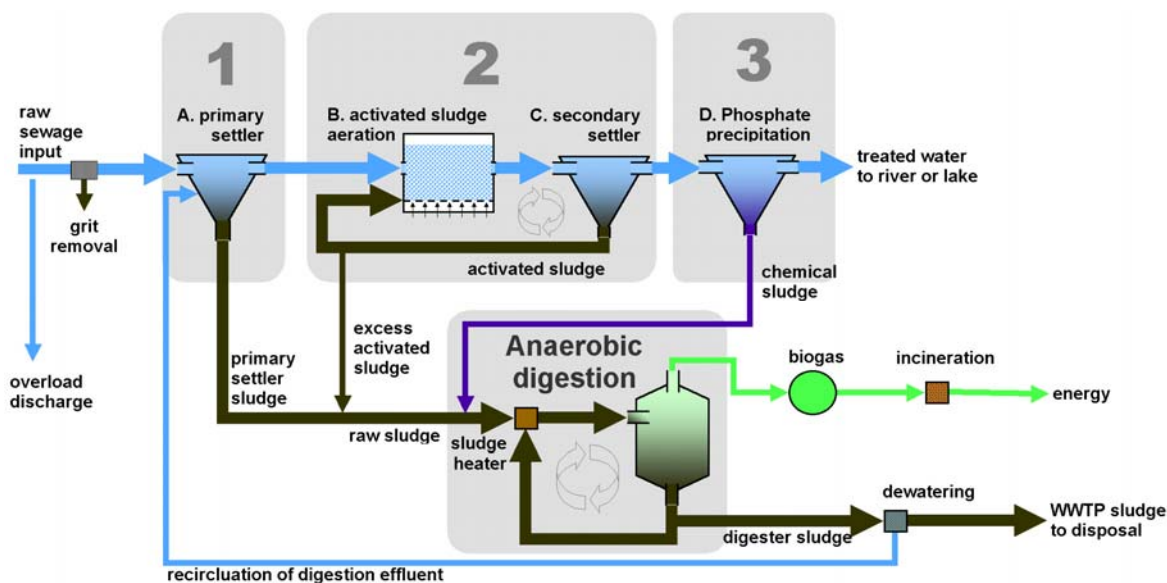

Figure 6.10. Scheme of the municipal wastewater treatment plant considered (Doka 2003).

Figure 6.10 shows a diagram of the treatment process considered in the MWWTP. It consists of transport through a sewer, primary settling, aerobic biological treatment with partial nitrification, and tertiary treatment for removal of phosphate by means of chemical precipitation. Mixed sludge from primary and secondary settling is digested in an anaerobic reactor, producing biogas that is used for cogeneration of electricity and heat. Digested sludge is dewatered and disposed as fertilizer or in a waste incinerator. These processes are modeled in the LCA database used in the study, through a calculation tool run in an Excel spreadsheet. This tool allows to calculate the environmental burdens (production of infrastructure, consumption of energy, chemicals, disposal of the excess sludge, etc.) of treating a specific wastewater, the composition of which is defined by the user. The performance of the plant, namely transfer coefficients, auxiliary materials consumption, energy balance, etc., is determined by using average data from Swiss MWWTPs as well as literature data. A detailed description of this model can be found in Doka (2003).

#### 6.2.6.4. Management of spent catalysts: iron and titanium dioxide

One of the issues that had to be addressed in the study concerning the photocatalytic plants is the fate of the spent catalysts. In chapter 5, waste catalyst management was deliberately excluded, in order to simplify the study, but in a detailed LCA it should be included.

Titanium dioxide is assumed to be reused 10 times in a closed cycle (Malato et al. 2000), while iron is not reused due to the low concentration needed ( $20 \text{ mg l}^{-1}$ ). In a full-scale plant the catalysts would be separated from the treated water in the neutralization stage. In the photo-Fenton case neutralization is needed to raise the pH from 3 to around 7, involving the precipitation of iron as hydroxides, which are next settled. In heterogeneous photocatalysis, titanium would be separated by attaining the point of zero charge at pH around 7 (Blanco et al. 2001); in these conditions, about 97% of the particles are settled in less than 5 hours, while the remaining 3% can be separated by a microfiltration system (Fernández-Ibáñez et al. 2003). A  $\text{TiO}_2$  sedimentation pilot-system following these procedures is shown in figure 6.11.

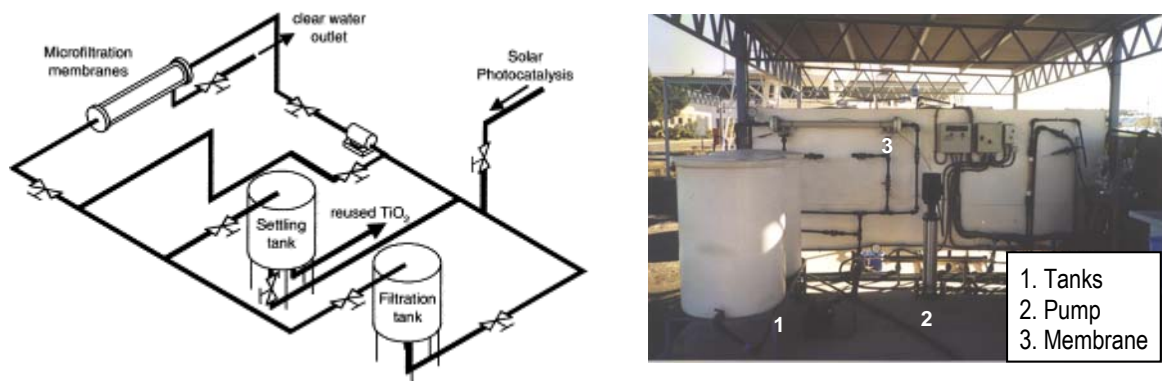

Figure 6.11. Pilot  $\text{TiO}_2$  separation system at PSA. Source: Fernández-Ibáñez et al. 2004.

Once iron hydroxides or titanium dioxide become waste they have to be properly managed. The separation process yields the spent catalyst in the form of a slurry. Due to the relatively small amount to be produced, it has been assumed that a dewatering (filter press or centrifuge) is not justified. Therefore, only a simple thickening process has been considered, from which the sludge is retired at about 5% dry mass.

With regard to the final fate of this chemical sludge, it must be taken into account that it has been in contact with potentially toxic substances, and for this reason we exclude recycling as a management option. On the other hand, the moisture content and the inorganic nature of the sludge, makes it unsuitable for energy recovery in an incinerator. The only option that remains, then, is disposal in a landfill. However, due to the high moisture and concentration of metals, it is assumed that the sludge undergoes a stabilization step with cement prior to disposal.

#### 6.2.6.5. Management of spent activated carbon

Saturated GAC can be managed in several ways, depending on the carbon usage rate (Zanitsch and Stenzel 1978): small amounts of GAC are usually used on a throwaway basis. This means that saturated carbon is directly disposed, either in a landfill, or most conveniently in an incinerator, in order to destroy the adsorbed pollutants and recover energy. The second option is to have the carbon reactivated off-site, and the third is to have a reactivation system on-site. According to USEPA (1973), to make GAC economically feasible for wastewater treatment in most applications, it must be reactivated and reused.

The objective of the regeneration process is to remove from the carbon pore structure the previously adsorbed materials. This is done in most cases by thermal reactivation in a multiple hearth furnace, in which the GAC is loaded and subject to the following processes (Eckenfelder 1989): drying, thermal desorption, and high-temperature heat treatment (650 to 980 °C) in the presence of limited quantities of water vapour, flue gas and oxygen. Adsorbed organic substances are pyrolysed, oxidized and further treated in an afterburner. As a result of attrition during transport/handling and burn-off during the thermal treatment, an average loss of 10% carbon occurs (Nijdam et al. 1999; Romero-Hernández 2004a, 2004b; Roskill Information Services 1998). This loss is compensated by supplying fresh carbon.

The small carbon usage rate calculated for treating 2500  $\text{m}^3/\text{year}$  of femac wastewaters, 25 kg/day (see section 5.1.2.7) implies that on-site reactivation must be discarded, due to the high capital costs. It could be even debatable whether the

carbon should be off-site reactivated or disposed<sup>8</sup>. Nevertheless, spent GAC has been considered in the present study to be off-site regenerated in a central facility and returned to the customer, replacing losses with fresh GAC.

### 6.2.7. Function and functional unit

The function of a wastewater treatment system can be defined as the removal of pollution from water until a required quality level is achieved that allows discharge of the effluent. In our study, this means that toxic compounds and intermediates must be destroyed, and organic matter and nutrients remaining in the wastewater must be removed until compliance with the discharge limits to river-bed.

Then the functional unit has been defined as:

*“To treat 1 m<sup>3</sup> of synthetic Femac wastewater (500 mg l<sup>-1</sup>) in order to destroy non-biodegradable or toxic compounds, achieving an effluent quality that allows release to the aquatic ecosystem”.*

This function and functional unit is valid for all AOPs as well as for GAC adsorption: AOPs eliminate toxicity by oxidizing the responsible compounds until biodegradability is achieved. On the other hand, GAC adsorption only changes the phase of the toxic compounds from aqueous to solid, but when spent GAC is regenerated, the pollutants are destroyed too. The remaining biodegradable pollutants of these treatments, if any, are sent to a MWWTP and finally the effluent is discharged to the river.

### 6.2.8. System description and boundaries

The system under study includes, in principle, all those processes needed to fulfill the functional unit. A common flow diagram for the coupled advanced oxidation-biological process is depicted in figure 6.12, while figure 6.13 shows the equivalent system for GAC adsorption. In this section, first a distinction is made between the foreground and background system, and next the system boundaries are defined. According to Guinée et al. (2002), three types of boundaries have to be distinguished: between the product system and the environment, between included and disregarded processes (cut-off) and between product systems (allocation).

---

<sup>8</sup> The only carbon regenerator in the area of Barcelona, Aguas de Levante S.A., does not accept carbon loads smaller than 10 tons, as it is not profitable taking into account the size of the furnace (Cortés-Russell 2005). Nevertheless, according to Calgon Carbon

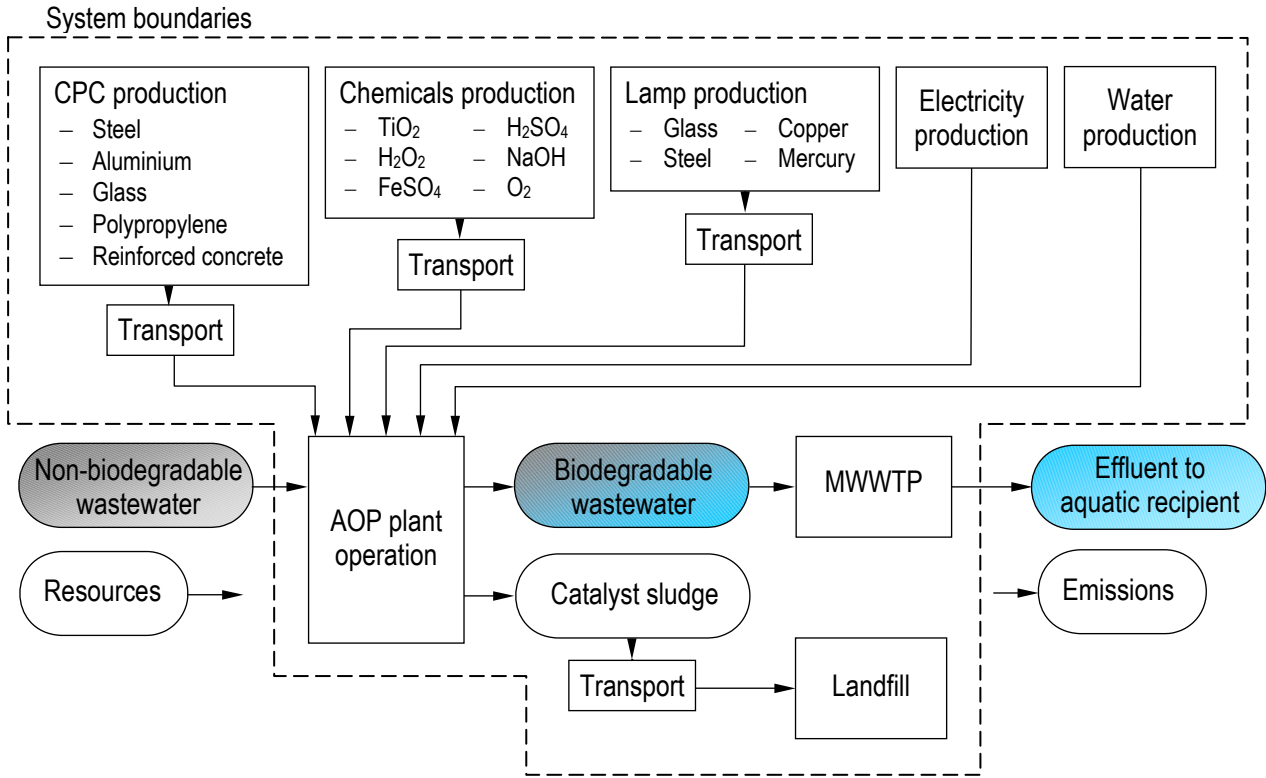

Figure 6.12. Flow diagram and system boundaries for the coupled advanced oxidation-biological system.

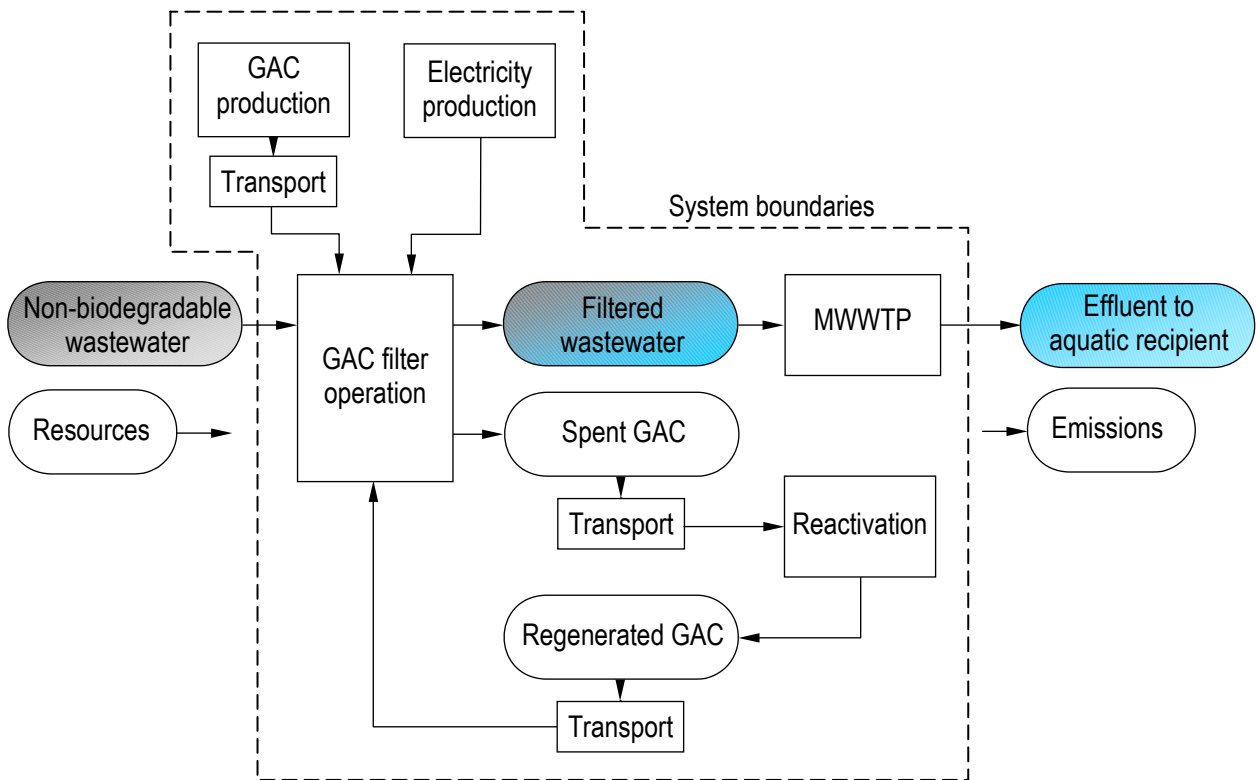

Figure 6.13. Flow diagram and system boundaries for the GAC adsorption system.

Corporation, quantities as low as 2 tons can be accepted for regeneration (Magi 2005).

### 6.2.8.1. Background and foreground system

For convenience, the processes in an LCA study can be divided into a foreground and a background system, where the foreground system consists of those processes directly affected by decisions based on the study, while the background system consists of all other processes which only indirectly are affected by measures taken in the foreground system (Tillman 2000; Clift 2005). Applying this definition to the system depicted in figure 6.12, it is concluded that the foreground system is the AOP plant operation, plus the biological treatment and spent catalyst management. Also production of CPCs is in the foreground; nonetheless, as CPC production we refer here to CPC characteristics and design, since production of the materials incorporated in CPCs (glass, steel, etc.) is part of the background system. For GAC adsorption (figure 6.13), only the operation of the plant and management of the spent carbon is considered to constitute the foreground system.

### 6.2.8.2. Boundaries between the economy and the environment

In LCA, all flows should be followed until the inputs and outputs have all been translated into environmental interventions<sup>9</sup>. To create a clear distinction between the product system and the environment, and between elementary and other flows, the system-environment boundary has to be explicitly defined (Guinée et al. 2002).

In general, the boundaries are those considered by the authors of the LCA database used, Ecoinvent 2000 (Frischknecht et al. 2004). As only this database is used, inconsistencies derived from different data sources are avoided. Particular issues such as landfills are regarded as economic processes and therefore are included within the system. Water and wastewater treatment are also regarded as economic processes; this implies that tap water is not a resource but a delivered product with upstream impacts, and releases to a sewage system are not considered as emissions to the environment, but only the releases of the treated wastewater after sewage treatment are considered as such. On the other hand, Ecoinvent 2000 considers soil as part of the environment, hence substances emitted to soil are not further modeled in the inventory phase, but in LCIA.

### 6.2.8.3. Cut-off rules

Production of infrastructure for the plants (building materials, piping, tanks, reactors, and other equipment) is not included, since it is assumed that the environmental impacts related to plant erection are of minor importance as compared to the operation phase. This assumption has not been considered valid for solar-driven AOPs, as these plants need high surfaces of solar collectors. In addition, as these plants use solar energy, it is assumed that the impact in the operation phase is not so important as compared to conventional WWTPs, thus making infrastructure production more relevant in relative terms.

As for plant dismantling, it has been excluded for all alternatives, even solar based-AOPs, and also in GAC adsorption, since the contribution to the overall impact is also very low (Dixon et al. 2003; Gaterell and Lester 2000).

### 6.2.8.4. Allocation

In the system under study, the main allocation problems arise in those processes related to waste management, namely treatment of wastewater in the MWWTP, and landfilling of residues. These are clear cases of multi-input processes that require partitioning (Udo de Haes and Van Halen 1997; Huppes and Schneider 1994; Sundqvist 1997; Bez et al. 1998; Nielsen and Hauschild 1998; Dalemo 1997). COD emissions from a MWWTP effluent, cadmium emissions in landfill

---

<sup>9</sup> Natural resources as extracted from nature (including land use) and emissions of pollutants to: air, natural water recipients and soil.

leachate or in incinerator exhaust gas are examples of environmental burdens that must be distributed among all the waste flows entering the treatment. This problem has been solved in the study by using the Ecoinvent 2000 models for MWWTP and landfilling. These tools consist on Excel spreadsheets included in the Ecoinvent database, which allow the calculation of LCIs for user-specified waste. The main input to these models is the waste's chemical composition, and some scenario conditions, such as size of the MWWTP and type of landfill (inert waste, toxic waste, etc.). The model allocates the different environmental burdens (energy consumption, emissions, etc.) to the particular waste stream under study, according to its chemical composition, finally obtaining an inventory table in ecoinvent format, that can be directly introduced in a LCA software like Simapro. Details on the allocation rules and model description can be found in Doka (2003).

## 6.2.9. Other hypothesis

In this section several assumptions made during the study or facts to be taken into account but not included in previous sections are presented and discussed.

### 6.2.9.1. Plant lifetime

Choosing a given useful life for the treatment plants has consequences on the following aspects:

- From an environmental point of view, the infrastructure impact per m<sup>3</sup> wastewater treated decreases with increasing useful life, since the overall impact of the materials invested is distributed among an increasing volume of water treated during the operating life. As infrastructure production is only included in solar-driven AOPs, these treatments will be affected by the choice, while the remaining treatments will not.
- From an economic point of view, the investment cost per m<sup>3</sup> also decreases with increasing useful life, due to the same reason explained above.

In conventional cost assessments of industrial WWTPs, 10 years is the period considered to annualize investment costs. Nevertheless, this does not mean that the plants can not last more than 10 years, but that they need to be amortized at the end of such period. According to Ecosystem, the company in charge of designing the CADOX demonstration plant, a solar-driven photocatalytic WWTP can operate at least for 15 years, during which only the optical elements in the CPCs (mirrors and glass tubes) should be substituted once by new ones. This figure, 15 years, has been chosen as time frame for the environmental assessment of solar-driven treatments and due to lack of data, it has been also applied for the remaining treatments, also for GAC adsorption.

### 6.2.9.2. Mode of operation

By mode of operation we refer to two parameters: continuous/discontinuous mode, and the amount of operating hours that the plants can potentially work. These issues are discussed here and the assumptions are summarized in table 6.6.

Table 6.6. Operation parameters considered in the wastewater treatments.

Treatment	Mode	Operating time
Fe (solar), Ti (solar)	Discontinuous	4,380 hours/year
Fe (lamp), O <sub>3</sub> , GAC	Continuous	8,760 hours/year



Concerning solar-driven AOP plants, applying either heterogeneous photocatalysis or photo-Fenton, they have been up to date designed to work in batch mode (Blanco and Malato 2003; Blanco et al. 2004a), due to the lack of uniformity in solar energy input. For this reason, the photo-Fenton reactor of the CADOX demonstration plant has been designed to operate in discontinuous mode. As for the number of yearly working hours, it is clear that solar plants are limited by the availability of solar light, and hence their potential operation is 12 hours/day or 4,380 hours/year. With regard to non-solar plants (treatments based on lamps, ozone or GAC), the most usual mode of operation is in continuous, and they can potentially work 24 hours/day or 8,760 hours/year.

#### 6.2.9.3. Overdimensioning

When designing WWTPs, engineers usually apply safety factors to ensure enough residence time or plant capacity if variations in wastewater flow or composition occur. This results in the plant being overdimensioned, in terms of size and equipment. Solar photocatalytic plants, for example, are designed to have 25% higher CPC area than strictly needed from feasibility tests (Blanco and Malato 2003). In the present study, however, all treatment options have been modeled as having the minimum requirements in size and equipment: CPC area, pumps, number of lamps, ozone generator, etc.

#### 6.2.9.4. Lamp irradiation

Pilot plant experiments applying lamp-driven photo-Fenton have not been carried out within the CADOX project. Therefore the energy that would be consumed by a lamp reactor has been obtained by estimation. The approach taken is basically to calculate the lamp power needed to substitute a given CPC surface, or in other words, to find out how many lamps are needed to supply the same amount of UV photons that a CPC is able to collect from the sun. It is important to note that this estimation does not consider the efficiencies of both the solar and the lamp system in driving the photons into the photochemical reactor.

There is a wide range of commercial UV lamps in the market, differing in power output, spectrum and useful life among other factors. The most frequently used are low-pressure and middle-pressure discharge lamps (Sattler 2004; Alexiadis and Mazzarino 2005). In the present the approach by Blanco (2002) is followed, who compared the relative performance of solar and artificial irradiation for photocatalytic processes on the basis of low-pressure mercury vapour fluorescent lamps.

#### 6.2.9.5. Transports

The transport processes discussed here consist mainly of the delivery of materials to the AOP/GAC plant, either for infrastructure or for operation, and transport of waste materials from the plant to the corresponding waste treatment facility: residual material landfill or GAC reactivation. An attempt has been made to consider the transport modes and distances representative for western Europe, which have been determined in most cases by means of the LCA database used, Ecoinvent 2000 (Frischknecht et al. 2004). Transport operations not shown in table 6.7 lie within the background system and are already included in the Ecoinvent datasets.

Table 6.7. Data used for transport services in the foreground system.

Material	km train	km lorry 32 T	km lorry 16 T	Source and comments
Infrastructure materials				All distances from Ecoinvent database (Frischknecht et al. 2004).
- Concrete		50		
- Steel (reinforcing/ stainless/galvanized)	200	100		
- Aluminium	200	100		
- Glass	600	100		
- Polypropylene	200	100		
Chemicals and ancillary materials				Distances for hydrogen peroxide, ferrous sulphate and titanium dioxide are not specified in Ecoinvent; they are given the values for general chemicals in the database. Distance for fresh GAC from Meier (1997) and for lamps it is assumed.
- Oxygen	100	50		
- Hydrogen peroxide	600	100		
- Ferrous sulphate	600	100		
- Titanium dioxide	600	100		
- Sulphuric acid	600	100		
- Sodium hydroxide	600	100		
- Fresh GAC		700		
- UV lamps		500		
Solid waste				Distance for catalysts to landfill is from Ecoinvent database, while for spent GAC is from Meier (1997).
- Spent titanium dioxide			50	
- Spent iron (as hydroxides)			50	
- Spent GAC		700		

## 6.2.10. Data collection

As in chapter 5, two data levels must be distinguished corresponding to the foreground system, from which data is directly collected, and the background system, that is modeled by means of a commercial LCA database. In this section the data used is presented. Nevertheless, during the inventory phase (section 6.3), more information on these data can be found.

Table 6.8 summarizes all the processes and the data collected in order to carry out the inventory analysis of the foreground system. Most of the data for AOP plants are derived from the pilot plant experiments, although data from full-scale have also been used wherever possible, namely for solar field infrastructure and for ozone production. The weakest data correspond to lamp-based photo-Fenton, since experimental data is not available from the CADOX project. Therefore an estimation of the lamp power needed is made. In addition, data concerning production of the lamps are incomplete. Literature data have been used for GAC production and reactivation processes, since these are not included in Ecoinvent database. Finally models for calculation of environmental burdens from sewage treatment and landfilling have been employed.

Concerning the background system, all inventory data are obtained from the Ecoinvent database version 1.1 (Frischknecht et al. 2004). However, as the system is more complex and studied in more detail than in chapter 5, the number of datasets used is substantially higher and they are not detailed here, but in the inventory analysis.

Table 6.8. Summary of data sources in the foreground system.

Process	Sources
CPC infrastructure	Data from the first commercial plant applying solar photocatalysis, owned by Albaida Recursos Naturales y Medioambiente S.A. in Almería, started in 2004. Inventory of materials per m <sup>2</sup> of CPC in this plant, supplied by the plant designer, Ecosystem. CPC area is calculated for each solar AOP from the experimental results obtained in the CADOX pilot plants (Maldonado et al. 2005a; Passarinho and Farinha 2005).
Chemicals consumed by AOPs (H <sub>2</sub> O <sub>2</sub> , O <sub>2</sub> , FeSO <sub>4</sub> , TiO <sub>2</sub> , H <sub>2</sub> SO <sub>4</sub> , NaOH)	Data derived from the CADOX pilot plant experiments using synthetic Femac wastewaters (Maldonado et al. 2005a; Passarinho and Farinha 2005). All consumptions obtained from the dose applied, except oxygen consumption, which is calculated from the ozone consumed and ozoniser efficiency reported by Trailigaz (Perrot 2005).
Water consumed by AOPs	The average consumption for cleaning of CPCs has been obtained from the Albaida plant. Cooling water used by the ozoniser is obtained from the equipment supplied by Trailigaz for the CADOX demonstration plant (Perrot 2005).
GAC consumption	Derived from laboratory experiments in column test (see section 6.2.5.2).
Transports	Distances and transport models suggested by the Ecoinvent database for western Europe (Frischknecht et al. 2004). For GAC the distance is from Meier (1997) and for lamps it has been estimated. See section 6.2.9.5 for details.
Number of UV lamps	Estimated using the methodology by Blanco (2002). Estimation from the amount of photons needed by the solar photo-Fenton process and the lamp UV output considering conventional Philips suntanning lamps.
Production of UV lamps	Includes only an estimation of the material composition of a fluorescent lamp for special uses. Data obtained from the European Lamp Companies Federation ( <a href="http://www.elcfd.org/lighting_material.html">http://www.elcfd.org/lighting_material.html</a> ) and a catalan lamp recycling company (Ribera 2005).
Energy consumed by ozoniser and ozone destructor	Obtained from Trailigaz. Data from the equipment projected for the CADOX demonstration plant (Perrot 2005).
Pumping requirements	For solar AOPs the pump power is extrapolated from Albaida plant. For ozonation it is obtained from the equipment projected by Trailigaz for the CADOX demonstration plant (Perrot 2005). For lamp-driven photo-Fenton and GAC adsorption the pump power has been determined by Ecosystem (Vincent 2005).
TiO <sub>2</sub> microfiltration	Energy consumed by this process is derived from a pilot plant in PSA (Fernández-Ibáñez et al. 2004).
Stirring	Mechanical stirrer power has been determined by Ecosystem (Vincent 2005).
Effluent to MWWTP	The composition of the effluent from the advanced oxidation step is obtained from the CADOX pilot plant experiments using synthetic Femac wastewaters (Maldonado et al. 2005a; Passarinho and Farinha 2005). For GAC adsorption the data from the column test with femac is used to characterise the effluent.
MWWTP	LCI for sewage treatment and management of sludge, obtained from the Ecoinvent tool for wastewater treatment (Doka 2003), specifying the composition of the input wastewater.
GAC production	Data from Meier (1997).
GAC reactivation	Data from Meier (1997).
Process emissions	The only process emissions that have been calculated are CO <sub>2</sub> from DOC degradation by AOPs and those from Femac combustion during reactivation of GAC, namely CO <sub>2</sub> and NO <sub>x</sub> which are calculated stoichiometrically. All other emissions to air, water and soil are included in the Ecoinvent datasets used.
Landfill	LCI for residual material landfill obtained from the Ecoinvent tool for landfills (Doka 2003), specifying the composition of the input waste. Stabilization of the waste with cement is taken into account.
Land use	Land occupied by the AOP and GAC plants is extrapolated from the Albaida Plant in Almería.

## 6.2.11. Life Cycle Impact Assessment methodology

LCIA has been applied basically following the same guidelines as in chapter 5. That means that the midpoint approach<sup>10</sup> (Jolliet et al. 2004; Bare et al. 2000) has been used.

### 6.2.11.1. Selection of impact categories, classification and characterisation

This case study pretends to be more detailed than the one presented in chapter 5. Hence the set of impact categories has been broadened in order to include four additional indicators, namely human toxicity, freshwater aquatic toxicity,

<sup>10</sup> Also called problem-oriented approach.

formation of photochemical oxidants and land use. In table 6.9 these impact categories are described along with those used in chapter 5. Most of the results of LCIA will be shown as characterisation scores, which is in accordance with ISO for comparative assertions disclosed to the public (ISO 1999), although normalisation and weighting have been applied in certain cases.

Table 6.9. Impact categories used in the study.

Impact category	Reference	Units	Description
Global Warming Potential (GWP)	Houghton et al. 1994, 1995	kg eq. CO <sub>2</sub>	Emissions as a result of human activities can affect the radiative forcing of the atmosphere, resulting in a rise in the earth's temperature. This, in turn, can cause adverse effects on ecosystem health, human health and material welfare. The indicator used is the Global Warming Potential (GWP). The GWP of a substance is the ratio between the contribution to the heat radiation absorption resulting from the instantaneous release of 1 kg of a greenhouse gas and an equal emission of CO <sub>2</sub> integrated over time. Biogenic CO <sub>2</sub> is not considered to be a contributor to the impact: If biogenic materials are grown on a sustainable basis (which has been assumed in the present study), then those emissions are considered simply to close the loop in the natural carbon cycle, returning to the atmosphere CO <sub>2</sub> that was originally removed by photosynthesis (IPCC, 1997).
Ozone Depletion Potential (ODP)	WMO 1992, 1995, 1998	kg eq. CFC-11	Some substances emitted by human activities lead to the breakdown of stratospheric ozone. This in turn cause a larger fraction of the sun's UV-B radiation to reach the earth's surface than in their absence. This can have harmful effects on human health, animal health, terrestrial and aquatic ecosystems, biochemical cycles, as well as on materials. The indicator used is the Ozone Depletion Potential (ODP). The ODP is defined as the ratio between ozone breakdown in a state of equilibrium due to annual emissions of a quantity of a substance released into the atmosphere and the breakdown of ozone in a state of equilibrium due to an equal quantity of CFC-11.
Human Toxicity Potential (HTP)	Huijbregts et al. 2000	kg eq. 1,4-dichlorobenzene	Contains the effects of toxic substances in the environment on humans. Toxicity categories are extremely complex. Reasons for this are the very large number of mechanisms, and the inter-media transport of substances. The fate of toxic substances, along with exposure and risk for humans are modelled with the fate model USES-LCA. This impact model provides four different time horizons for toxicity assessment: 20, 100, 500 years, and infinite time. The latter has been used in order to give the same importance to present and future impacts.
Freshwater Aquatic Toxicity Potential (FATP)	Huijbregts et al. 2000	kg eq. 1,4-dichlorobenzene	Eco-toxicological impacts are the effects of toxic substances on aquatic, terrestrial and sediment ecosystems. Toxicity categories are extremely complex. Reasons for this are the very large number of mechanisms, and the inter-media transport of substances. The fate of toxic substances, along with risk for ecosystems are modelled with the fate model USES-LCA. This impact model provides four different time horizons for toxicity assessment: 20, 100, 500 years, and infinite time. The latter has been used in order to give the same importance to present and future impacts.
Photochemical Oxidant Formation Potential (POFP)	Derwent et al. 1998; Jenkin and Hayman 1999	kg eq. ethene	Formation of reactive substances (mainly ozone), which are injurious to human health and ecosystems, and which may damage crops. Precursors of photo-oxidants are mainly VOCs, CO, and NO <sub>x</sub> . The latter, however, act as catalysts in the complex reactions. The impact indicator used is the Photochemical Ozone creation Potential (POCP). A POCP of a VOC is the ratio between the change in ozone concentration due to a change in the emission of that VOC and the change in the ozone concentration due to a change in the emission of ethylene.
Acidification Potential (AP)	Hauschild and Wenzel 1998	kg eq. SO <sub>2</sub>	Acidifying substances cause a large number of diverse impacts on soil, groundwater, surface water, organisms, ecosystems and materials (buildings). Examples are fish dying in scandinavian lakes, forest decline and the crumbling of building materials. The impact indicator used is based on an assessment of the number of moles of hydrogen ions which can potentially be released to the environment from one mole of the substance in question.

Eutrofication Potential (EP)	Heijungs et al. 1992	kg eq. $PO_4^{3-}$	Eutrophication includes all impacts due to a too high level of macronutrients in the aquatic ecosystems. This enrichment may cause an undesirable shift in the composition of species and an increased production of biomass. In addition, high nutrient concentrations can also make surface water and groundwater unacceptable for water supply. An increased production of biomass may lead to low oxygen concentrations because the decomposition of this biomass needs oxygen. The impact indicator is based on the contribution of N and P to the average composition of aquatic organisms ( $C_{106}H_{263}O_{110}N_{16}P$ ).
Energy Consumption (EC)	Frischknecht et al. 1998	MJ	Energy demand is an useful indicator of environmental impact and resource depletion. It represents a measure of the system's efficiency and implies lower uncertainty as compared to other impact categories. Included are the inputs of primary non-renewable energy sources, in MegaJoule. Renewable energy inputs are not taken into account, as these are regarded as sustainable.
Land use (LU)	Guinée et al. 2002	m <sup>2</sup> year	Land can be considered as a resource, which is temporarily unavailable due to a wide range of anthropogenic uses. Land also has life support functions and human interventions can cause effects on biodiversity. However characterisation of land-use-related impacts is not settled. Here land use is measured in m <sup>2</sup> year without making any difference between industrial, agricultural, natural or other types of land.

### 6.2.11.2. Normalisation and weighting

Normalisation has been applied only as a previous step to weighting, as it was done in chapter 5. As a consequence, normalised scores for each impact category are not shown. Instead, they are calculated and then aggregated to obtain a weighted score, although in this case the weighting factor is 1 for all categories, thus all of them are given the same relevance. The normalisation factors used are also those from chapter 5, corresponding to western Europe (van Oers 2001). Table 6.10 shows these factors along with those for the impact categories added in this case study.

Table 6.10. Normalisation factors for Western Europe in 1995.

Impact category	Units	Factor (kg/year)
Global Warming Potential (GWP)*	kg eq. CO <sub>2</sub> /year	4.82E+12
Ozone Depletion Potential (ODP)*	kg eq. CFC-11/year	8.30E+07
Human Toxicity Potential (HTP)*	kg eq. 1,4-dichlorobenzene	7.57E+12
Freshwater Aquatic Toxicity Potential (FATP)*	kg eq. 1,4-dichlorobenzene	5.05E+11
Photochemical Oxidant Formation Potential (POFP)*	kg eq. ethene	8.24E+09
Eutrophication Potential (EP)*	kg eq. $PO_4^{3-}$ /year	1.25E+09
Acidification Potential (AP)*	kg eq. SO <sub>2</sub> /year	2.94E+10
Energy consumption (EC)**	MJ	2.84E+13
Land Use (LU)*	m <sup>2</sup> year	3.27E+12

\* Source: van Oers (2001).

\*\* Source: calculated from van Oers (2001).

## 6.3. Inventory Analysis for Baseline Alternatives

In the inventory analysis the calculations leading to all inputs and outputs to/from the foreground system per functional unit are shown. Once this balance is made, these values are introduced in the software Simapro 6.0, which stores all the Ecoinvent datasets needed and calculates all the environmental interventions – the aggregated inventory table – for the system under study.

In section 6.3.1 the level of pollutant removal that must be achieved by all treatments is presented. Inputs (building materials, chemicals, energy, etc) and outputs (emissions, waste, etc.) are then calculated in the next sections based on that treatment goal. Finally section 6.3.5 presents a disaggregated inventory table summarizing all the information compiled.

### 6.3.1. DOC to be removed in order to achieve biodegradability

In order to achieve biodegradability, AOPs must completely destroy Femac and toxic intermediates. This biodegradability point was investigated during the pilot plant tests in PSA and INETI, and a DOC value was found below which the Zahn-Wellens test results were above 70% biodegradability in 28 days. On the other hand, the strategy of GAC adsorption is not to destroy the pollutant, but to change its phase from liquid to solid. Therefore, for the water to be acceptable in a MWWTP, all Femac and thus 100% DOC must be adsorbed by the carbon. The following table shows the level of DOC to be removed by all treatments.

Table 6.11. DOC removal to be achieved by all treatments to allow discharge to a MWWTP.

DOC removal	Fe (solar)	Ti (solar)	O3	Fe (lamp)	GAC
DOC <sub>0</sub> (mg l <sup>-1</sup> )	330	330	330	330	330
DOC <sub>f</sub> (mg l <sup>-1</sup> )	120	40	150	120	2
DOC Removed (%)	64%	88%	55%	64%	100%
DOC Removed (mg l <sup>-1</sup> )	210	290	180	210	328

### 6.3.2. Infrastructure for solar-based photocatalytic plants

As discussed in section 6.2.8.3, production of infrastructure is only taken into account for solar-driven treatments, namely photo-Fenton and heterogeneous photocatalysis. By infrastructure we refer to the production of solar collectors as well as terrain preparation. The environmental burdens associated to each treatment have been determined in two steps: first, the average inventory per m<sup>2</sup> CPC is obtained, and next the total CPC aperture area needed by each treatment is calculated from the pilot plant experiments.

#### 6.3.2.1. Inventory for CPC infrastructure

The pilot plant is not considered to be representative of a full-scale unit in terms of infrastructure. In addition, at the moment of carrying out the study, the CADOX demonstration plant was not built yet. For this reason, the inventory has been obtained from the commercial solar detoxification plant installed at Albaida Recursos Naturales y Medioambiente, S.A. in Almería, which has already been described in chapter 3 (section 3.4.4). Although this plant is designed to apply

photo-Fenton, the same kind of CPCs can be used for TiO<sub>2</sub>-based photocatalysis (Malato et al. 2004b). Therefore this is representative for both solar treatments tested in the CADOX project.

Table 6.12 shows the inventory per m<sup>2</sup> CPC. It includes not only the basic materials (steel, aluminium, plastic, etc.) but also in several cases further production processes such as moulding, anodising or galvanizing. The figures for glass tubes and aluminium mirrors are doubled, since these elements have to be substituted once during the lifetime of the plant (Vincent 2005) to ensure optical performance. Transports to the plant site for all materials are calculated and aggregated in a single value, taking into account the transport distances set in section 6.2.9.5.

Table 6.12. Inventory per m<sup>2</sup> CPC at Albaida plant.

Concept	Materials and processes	Amount per m <sup>2</sup> CPC	Ecoinvent datasets used and comments
Estructural elements	Stainless steel (kg)	7.81	7.81 kg <i>Chromium steel 18/8, at plant, RER</i>
Screws and minor estructural elements	Galvanized steel (kg)	0.17	0.17 kg <i>Steel, low-alloyed, at plant, RER</i> + 0.0102 m <sup>2</sup> <i>Zinc coating, pieces, RER</i> (assuming 60 m <sup>2</sup> surface per kg of metal, according to Ecoinvent database)
Estructural elements, mirrors (x2)	Anodised aluminium (kg)	9.68	9.68 kg <i>Aluminium, production mix, at plant, RER</i> + 9.68 kg <i>Section bar extrusion, aluminium, RER</i> + 5.57 m <sup>2</sup> <i>anodising, aluminium sheet, RER</i> (actual area of aluminium profiles and mirrors)
Reactor tubes (x2)	Borosilicate glass (kg)	6.72	6.72 kg <i>Glass tube, borosilicate, at plant, DE</i>
Pipes and valves	Polypropylene (kg)	1.40	1.4 kg <i>Polypropylene, granulate, at plant, RER</i> + 0.2 kg <i>Extrusion, plastic pipes, RER</i> + 1.2 kg <i>Injection moulding, RER</i> (pipes are extruded while valves and U-shaped unions are injected)
Paved platform	Concrete (kg)	750	0.32 m <sup>3</sup> <i>Concrete, normal, at plant, CH</i> (assuming a density of 2,300 kg/m <sup>3</sup> )
Paved platform	Reinforcing steel (kg)	31	31 kg <i>Reinforcing steel, at plant, RER</i>
Paved platform limit	Concrete curb (kg)	46	0.02 m <sup>3</sup> <i>autoclaved aerated concrete block, at plant, CH</i> (assuming a density of 2,300 kg)
Delivery of materials	Transport by train (kg · km)	14,089	14,089 kg · km <i>Transport, freight, rail, RER</i>
Delivery of materials	Transport by truck (kg · km)	45,579	45,579 kg · km <i>Transport, lorry 32t, RER</i>

Source: calculated from Ecosystem data.

### 6.3.2.2. Calculation of CPC area

Once the inventory for an average m<sup>2</sup> of CPC in a solar photocatalytic plant is defined, the total aperture area needed to treat 2,500 m<sup>3</sup> year<sup>-1</sup> of Femac wastewater by photo-Fenton and heterogeneous photocatalysis has to be calculated. This is done using the following expression (Blanco and Malato 2003):

$$S_{CPC} = \frac{Q_{UV} \cdot V}{T_{SUN} \cdot 3600 \cdot UV_G} \quad (6.2)$$

Where:

$S_{CPC}$  is the area of CPC needed by the plant (m<sup>2</sup>),

$V$  is the wastewater volume to be treated (2,500,000 litres year<sup>-1</sup>),

$T_{SUN}$  is the overall operation time (4,380 hours year<sup>-1</sup>),

3,600 is a conversion factor (seconds hour<sup>-1</sup>),

$UV_G$  is the yearly global average UV irradiation, sunrise to sunset, at the plant site ( $18,6 \text{ W m}^{-2}$ ), and  $Q_{UV}$  is the accumulated UV radiation needed by the photocatalytic reactor to reach a given level of pollutant removal ( $\text{J litre}^{-1}$ ). This parameter is calculated in Appendix 6.1, and shown in table 6.13.

Table 6.13 shows the results of calculating the CPC area required for a solar plant treating Femac. Taking into account that  $2,500 \text{ m}^3/\text{year}$  will be treated during 15 years, the area attributable to the functional unit ( $1 \text{ m}^3$ ) can be determined; This area is then used along with table 6.12 to quantify the environmental burdens of infrastructure per functional unit.

Table 6.13. Calculation of CPC area needed by a solar photocatalytic plant and CPC area attributable to the functional unit.

Parameter	Fe (solar)	Ti (solar)
$Q_{UV}$ ( $\text{J litre}^{-1}$ ) (Appendix 6.1)	12,000	252,000
$S_{CPC}$ ( $\text{m}^2$ ) applying eq. 6.2	100	2,150
$S_{CPC}$ per FU ( $\text{m}^2 \text{m}^{-3}$ wastewater)*	2,7E-03	5,7E-02

\* The plant treats  $2,500 \text{ m}^3/\text{year}$  during a useful life of 15 years.

### 6.3.3. Electricity

In this section all the operations or elements consuming electricity for each treatment are identified and the corresponding consumption per functional unit is quantified.

#### 6.3.3.1. Pumping

Pumping of the wastewater is a common process for all treatments, although the power needed can vary. For solar-driven treatments the pump power has been considered to be in proportion to the CPC area (Vincent 2005) and the Albaida plant has been taken as model. The power requirements are calculated using equation 6.3:

$$E_{PUMP} = \frac{kW_A \cdot S_{CPC} \cdot T_{SUN}}{S_{CPC,A} \cdot V} \quad (6.3)$$

Where:

$E_{PUMP}$  is the electricity consumed by the pump of the solar photocatalytic plant under study ( $\text{kWh m}^{-3}$ ),

$kW_A$  is the pump power at the Albaida plant ( $0.55 \text{ kW}$ ),

$S_{CPC,A}$  is the CPC area at the Albaida plant ( $150 \text{ m}^2$ ),

$S_{CPC}$  is the CPC area of the plant under study ( $\text{m}^2$ ),

$V$  is the yearly wastewater volume to be treated ( $2,500 \text{ m}^3 \text{ year}^{-1}$ ), and

$T_{SUN}$  is the overall operation time of the solar photocatalytic plant ( $4,380 \text{ hours year}^{-1}$ ).

Taking into account the CPC areas calculated in section 6.3.2.2, the resulting energy requirements are  $0.6$  and  $13.8 \text{ kWh m}^{-3}$  for photo-Fenton and  $\text{TiO}_2$ -based photocatalysis.

The pump power needed by a photo-Fenton process using UV lamps has been quantified by Ecosystem as  $300 \text{ W}$  (Vincent 2005). As the flow is  $0.285 \text{ m}^3 \text{ hour}^{-1}$ ,  $1.05 \text{ kWh m}^{-3}$  wastewater will be consumed by this treatment.



In order to estimate the pump power for a GAC filter, first the size of it has to be specified. The plant would consist of two TIGG C75 RX adsorption columns in series, each with the following characteristics: 4.11 m<sup>3</sup> of total volume (1.45 m diameter, 2.49 m height) and a carbon bed volume equal to 63% of the total column (TIGG 2005). For a flow rate of 0.285 m<sup>3</sup> hour<sup>-1</sup>, the resulting pressure drop is very low, of about 1 cm water, allowing the installation of a very small pump. According to Ecosystem (Vincent 2005), a 40 W pump would be adequate, giving an specific electricity consumption of 0.14 kWh m<sup>-3</sup> wastewater.

The ozonation plant projected for the CADOX demonstration plant consumes 1.55 kWh kg<sup>-1</sup> ozone produced (Perrot 2005). According to the pilot plant experiments (Maldonado et al. 2005a; Perrot 2005), 0.8 kg ozone must be consumed per m<sup>3</sup> of Femac wastewater. Considering that average transfer efficiency is 50%, then 1.6 kg ozone must be produced per m<sup>3</sup> wastewater, giving a power consumption of 2.5 kWh m<sup>-3</sup> wastewater.

### 6.3.3.2. Ozonisor

The electricity consumed to produce ozone has been determined from the specifications of the equipment chosen by Trailigaz to work in the CADOX demonstration plant. From the data supplied by Trailigaz (Perrot 2005), the ozonisor OZC 1016 consumes 12 kWh per kg ozone produced, at a concentration of 11.7% w/w. According to the pilot plant experiments (Maldonado et al. 2005a; Perrot 2005), 0.8 kg ozone are effectively consumed per m<sup>3</sup> of Femac wastewater to reach the biodegradability point. Considering that average transfer efficiency is 50%, then 1.6 kg ozone must be produced per m<sup>3</sup> wastewater, giving a power consumption of 19.2 kWh m<sup>-3</sup> wastewater.

### 6.3.3.3. Lamps

The energy that would be consumed by a lamp reactor has been obtained by estimation. The approach taken is basically to calculate how many lamps are needed to supply the same amount of UV photons that a CPC is able to collect from the sun. It is important to note that this estimation does not consider the efficiencies of both the solar and the lamp system in driving the photons into the photochemical reactor.

In order to calculate how many lamps are needed, we must first define the kind of lamps that will be used. In the present study the approach by Blanco (2002) has been followed, comparing the relative performance of solar and artificial irradiation for photocatalytic processes on the basis of low-pressure mercury vapour fluorescent lamps. The model chosen (table 6.14) for the present study is a Philips lamp typically used for suntanning, emitting mostly in the UV-A range.

Table 6.14. UV lamp specifications.



Model name	Philips CLEO Professional
Weight	0.41 kg
Useful life	800 hours
Power	160 W
UV power	36 W
UV peak emission	350 nm
UV-B/UV-A IEC	1.4 %

Source: Philips.

Once the lamp parameters are set, the energy consumed in a photo-Fenton application is calculated using equation 6.4:

$$E_{LAMP} = \frac{kW_{LAMP} \cdot T_{LAMP} \cdot N_{LAMP,m^2} \cdot S_{CPC}}{V} \quad (6.4)$$

Where:

$E_{LAMP}$  is the electricity consumption due to lamp irradiation (kWh m<sup>-3</sup>),

$kW_{LAMP}$  is the lamp power (0.16 kW),

$T_{LAMP}$  is the overall operation time of a lamp-driven plant (8,760 hours year<sup>-1</sup>),

$V$  is the yearly volume of wastewater to be treated (2,500 m<sup>3</sup> year<sup>-1</sup>)

$S_{CPC}$  is the CPC area calculated for an equivalent plant using solar light instead of lamps (100 m<sup>2</sup>), and

$N_{LAMP,m^2}$  is the equivalency factor between lamps and CPC area (lamp units m<sup>-2</sup> CPC), which is in turn calculated with the following equation:

$$N_{LAMP,m^2} = \frac{5.81 \cdot 10^{21} \cdot UV_G \cdot T_{SUN}}{n_{LAMP} \cdot T_{LAMP}} \quad (6.5)$$

Where:

$5.81 \cdot 10^{21}$  is the number of UV photons supplied by solar radiation (photons Wh<sup>-1</sup>) (Blanco 2002),

$UV_G$  is the yearly global solar average UV irradiation, sunrise to sunset, at the plant site (18,6 W m<sup>-2</sup>),

$T_{SUN}$  is the overall operation time of a solar plant (4,380 hours year<sup>-1</sup>),

$T_{LAMP}$  is the overall operation time of a lamp-driven plant (8,760 hours year<sup>-1</sup>), and

$n_{LAMP}$  is the UV photon supply rate by a lamp (photons hour<sup>-1</sup>), which is calculated from the lamp specifications using equation 6.6:

$$n_{LAMP} = \frac{W_{UV,LAMP} \cdot 3600 \cdot \lambda_{UV,LAMP}}{h \cdot c} \quad (6.6)$$

Where:

$W_{UV,LAMP}$  is the lamp power in the UV range, (36 W),

3,600 is a conversion factor (seconds hour<sup>-1</sup>),

$\lambda_{UV,LAMP}$  is the lamp's UV peak emission wavelength (3.5E-07 m),

$h$  is the Planck's constant (6.626E-34 J s), and

$c$  is the light speed (2.998E+08 m s<sup>-1</sup>).

From equation 6.5 it can be calculated that 0.24 Philips CLEO lamps are needed to substitute 1 m<sup>2</sup> CPC in Almería.

From equation 4, the power consumption for substituting a solar field of 100 m<sup>2</sup> CPC is 13.3 kWh m<sup>-3</sup>.

#### 6.3.3.4. Microfiltration

This operation is only applied by heterogenous photocatalysis to separate TiO<sub>2</sub> at the neutralization stage (see section 6.2.64). After allowing a few hours of gravity settling, the supernatant containing a few mg TiO<sub>2</sub> litre<sup>-1</sup> is passed through a membrane. The energy consumed by this process has been obtained by a pilot microfiltration plant at PSA (Fernández-Ibáñez et al. 2004), which has a filtering capacity similar to that needed by the solar photocatalytic application under study. The only energy consuming device is the pump making the water pass through the membrane. In the pilot tests,

0.39 m<sup>3</sup> supernatant were filtered in about 50-60 minutes with a 1.8 kW pump, giving an average figure of 4.3 kWh m<sup>-3</sup> wastewater.

### 6.3.3.5. Stirring

Those treatments needing a neutralization stage after the advanced oxidation step require a separate tank equipped with a mechanic stirrer, in order to homogenize the effluent. It is assumed that ozonation does not need a separated neutralization stage, since the base can be added during oxidation. Therefore only photo-Fenton, either using solar or artificial light, and heterogeneous photocatalysis must be provided a stirrer. A 0.75 kW device has been considered for a tank volume of 2.5 m<sup>3</sup>, being the time to complete the neutralization of about 15 minutes, leading to a consumption of 0.075 kWh m<sup>-3</sup>.

### 6.3.3.6. Overall consumption

The following table summarizes the overall electricity consumed per functional unit by each treatment, during operation of the plant. The Ecoinvent dataset used to account for the environmental burdens of producing electricity is *Electricity, medium voltage, production UCTE, at grid*.

Table 6.15. Inventory of electricity consumed per functional unit.

Power consumption	Fe (solar)	Ti (solar)	O3	Fe (lamp)	GAC
Ozonisator			19.2		
Pumping	0.64	13.8	2.5	1.05	0.14
Lamps				13.3	
Microfiltration		4.3			
Stirring	0.075	0.075		0.075	
<b>Total (kWh)</b>	<b>0.72</b>	<b>18.2</b>	<b>21.7</b>	<b>14.4</b>	<b>0.14</b>

## 6.3.4. Chemicals and ancillary materials

In this section the amount of materials (reactives, catalysts, water, etc.) consumed per functional unit during operation of the plant is calculated for each treatment.

### 6.3.4.1. Oxygen

Oxygen is consumed to produce ozone. The conversion efficiency has been determined from the specifications of the equipment chosen by Trailigaz to work in the CADOX demonstration plant. In addition, it has to be taken into account that not all ozone produced by the ozonisorator is effectively used in the oxidation, but a fraction is lost and decomposed by a thermal destructor connected to the contact columns. From the data supplied by Trailigaz (Perrot 2005), the ozonisorator OZC 1016 consumes 8.3 kg (5.8 Nm<sup>3</sup>) oxygen per kg ozone produced, at a concentration of 11.7% w/w. According to the pilot plant experiments (Maldonado et al. 2005a; Perrot 2005), 0.8 kg ozone are effectively consumed per m<sup>3</sup> of Femac wastewater to reach the biodegradability point, and the average transfer efficiency is 50%. Therefore 13.3 kg oxygen must be produced per m<sup>3</sup> wastewater. The Ecoinvent dataset used is *Oxygen, liquid, at plant, RER*.

#### 6.3.4.2. Hydrogen peroxide

Hydrogen peroxide is consumed by the photo-Fenton process, either using solar or artificial light. It is assumed in the calculations that the amount of chemicals consumed is independent of the light source. The degradation of Femac in the pilot plant required 50 mM litre<sup>-1</sup> of (pure) hydrogen peroxide (Maldonado et al. 2005a). Therefore 1.7 kg m<sup>-3</sup> of pure chemical must be consumed, equivalent to 6.3 kg of commercial grade hydrogen peroxide (purity of 297g litre<sup>-1</sup> and density of 1.1 kg litre<sup>-1</sup>). The Ecoinvent dataset used is *Hydrogen peroxide, 50% in H<sub>2</sub>O, at plant, RER*, specifying an amount of 1.7 kg, as this dataset is referred to pure peroxide production; the name *50% in H<sub>2</sub>O* refers only to the fact that this product is usually commercialized at this concentration, and it has to be taken into account in the transport calculations. In our case, however the figure that has to be considered is 30%.

#### 6.3.4.3. Ferrous sulphate

Ferrous sulphate is the iron source in the photo-Fenton process. The dose applied for degradation of Femac in the pilot plant experiments was always 20 mg Fe litre<sup>-1</sup> (Maldonado et al. 2005a), equivalent to 100 g m<sup>-3</sup> of heptahydrated ferrous sulphate. The Ecoinvent dataset chosen is *Iron sulphate, at plant, RER*.

#### 6.3.4.4. Titanium dioxide

The titanium catalyst was used by INETI in the pilot plant experiments at a concentration of 200 mg TiO<sub>2</sub> litre<sup>-1</sup> wastewater (Passarinho and Farinha 2005). It is assumed that after the oxidation process, this catalyst would be separated and reused 10 times (Malato et al. 2000). As a consequence, the real consumption is 0.02 kg m<sup>-3</sup> wastewater treated. The Ecoinvent dataset chosen is *Titanium dioxide, production mix, at plant, RER*.

#### 6.3.4.5. Sulphuric acid

The pH level must be adjusted to around 3 before applying the photo-Fenton process, since it is the optimum value to carry out the process. The average consumption of sulphuric acid in the pilot plant experiments treating Femac was 1.33 mM litre<sup>-1</sup> (Gernjak 2005), equivalent to 0.13 kg m<sup>-3</sup> of commercial sulphuric acid (98% pure). The Ecoinvent data set used is *Sulphuric acid, liquid, at plant, RER*.

#### 6.3.4.6. Sodium hydroxide

After the advanced oxidation step, the wastewater must be neutralized. This applies for the photo-Fenton process, which works at pH 3, but also for ozonation, since the formation of carboxylic acids during the degradation of Femac leads also to a pH level around 3. The average consumption of pure sodium hydroxide in the pilot plant experiments treating Femac was 2 mM litre<sup>-1</sup> (Gernjak 2005), equivalent to 0.16 kg m<sup>-3</sup> of commercial sodium hydroxide (50% pure). The Ecoinvent dataset used is *Sodium hydroxide, 50% in H<sub>2</sub>O, production mix, at plant, RER*, specifying an amount of 0.08 kg, as this dataset is referred to pure NaOH production; the name *50% in H<sub>2</sub>O* refers only to the fact that this product is usually commercialized at this concentration, and it has to be taken into account in the transport calculations.

#### 6.3.4.7. Activated carbon

The X/M ratio determined in the column test (section 6.2.5.2) is 138 mg Femac per g carbon. The wastewater contains 500 mg/litre Femac, therefore we need 3.63 kg carbon m<sup>-3</sup> of wastewater treated. This is the amount of carbon exhausted per m<sup>3</sup>, then the environmental burdens of regenerating 3.63 kg per functional unit must be taken into

account. During regeneration a 10% loss of carbon occurs (Meier 1997), being replaced by new carbon. Hence only the production of 0.36 kg activated carbon must be allocated to the functional unit.

The Ecoinvent database does not include data on GAC production from bituminous coal. The material and energy requirements for this process have been obtained from Meier (1997) and the corresponding Ecoinvent datasets have been used. The process consumes 2 kg crude coal per kg GAC, meaning that 50% of the carbon is burnt-off while the remaining 50% remains as final product. This has been modeled in the inventory (table 6.16) as the sum of 2 datasets: 1 kg of carbon from mine + 1 kg of carbon from mine and combusted in a furnace.

Table 6.16. Inventory for production of 1 kg activated carbon.

Concept	Materials and processes	Amount per kg GAC	Ecoinvent datasets used and comments
Raw material	Crude coal (kg)	2	1 kg <i>Hard coal mix, at regional storage, RER</i> + 30.4 MJ <i>Hard coal, burned in industrial furnace 1-10 MW, RER</i> (according to Ecoinvent database the gross calorific value of hard coal is 30.4 MJ/kg)
Transport from mine to activation plant	Transport by truck (kg km)	600	600 kg km <i>Transport, lorry 32t, RER</i>
Mixing, crushing, kiln drive	Electricity (kWh)	0.021	0.021 kWh <i>Electricity, medium voltage, production UCTE, at grid</i>
Washing of calcium carbonate	Hydrochloric acid (kg)	0.04	0.04 kg <i>Hydrochloric acid, 30% in H<sub>2</sub>O, at plant, RER</i>
Activation	Steam (kg)	3	3 kg <i>Steam, for chemical processes, at plant, RER</i>
Heating (1000 °C, 10 hours)	Natural gas (Nm <sup>3</sup> )	4.9	196 MJ <i>Natural gas, burned in industrial furnace &gt;100kW, RER</i> (according to Ecoinvent database the gross calorific value of natural gas is 40MJ Nm <sup>-3</sup> )

Source: adapted from Meier (1997).

The inventory on activated carbon production by Meier is the most detailed found. According to the author, (Meier 2005), these data were obtained directly from an industrial operator and cross-checked with an engineering company. Nevertheless, data recently published (Bayer et al. 2005), show relevant differences in some parameters, specially with regard to the natural gas consumed in the process, which is an order of magnitude lower according to Bayer and coworkers's data. This is a potential issue to take into account in a sensitivity analysis on the impact of the GAC adsorption system.

#### 6.3.4.8. UV Lamps

In section 6.3.3.3 it has been calculated that 24 UV lamps are needed if photo-Fenton is to be conducted by artificial light. The lamps considered have a useful time of 800 hours; the plant will then use 264 lamps every year, or 0.1 lamps m<sup>-3</sup>. It has not been possible to find detailed data on the production of a fluorescent lamp. As a consequence the approach taken is to define a rough material composition in percentage and apply it to the weight of a lamp unit (0.41 kg). Two sources have been used to define the lamp composition: the first one is the European Lamp Companies Federation (ELC)<sup>11</sup>, which also supplied data concerning the mercury content, a parameter currently restricted by european legislation (EU 2002). The general limit set by the Directive 2002/95 is 5 mg Hg lamp<sup>-1</sup>. However, lamps for special applications such as UV emission are exempt from complying with this value. The average value considered by

<sup>11</sup> [http://www.elcfed.org/lighting\\_material.html](http://www.elcfed.org/lighting_material.html)

ELC for special lamps is 30 mg/unit (Strickland 2005). The second data source is a catalan recycler of batteries and lamps, Pilagest<sup>12</sup>. Table 6.17 shows the material composition considered and the quantity consumed per functional unit.

Table 6.17. materials for lamp production.

Material <sup>a</sup>	Amount per lamp <sup>b</sup>	Ecoinvent datasets used
Glass (96%)	394 g	394 g <i>Flat glass, uncoated, at plant, RER</i>
Steel (2%)	8 g	8 g <i>Steel, low alloyed, at plant, RER</i>
Copper (2%)	8 g	8 g <i>Copper, at regional storage, RER</i>
Mercury (30 mg unit <sup>-1</sup> )	30 mg	30 mg <i>Mercury, liquid, at plant, GLO</i>

<sup>a</sup> Sources: ELC, Pilagest.

<sup>b</sup> The UV lamps considered weigh 0.41 kg.

#### 6.3.4.9. Water

Tap water is used by solar-based AOP plants for external cleaning of CPCs, in order to maintain their performance by preventing dust from settling in the mirrors and glass tubes. The average consumption of water for this purpose has been obtained from the Albaida plant, where this operation takes place every 10 days, using approximately 225 litres water to wash 150 m<sup>2</sup> CPCs (Hernández 2005), meaning 1.5 litres per m<sup>2</sup> per wash. If a plant having 100 m<sup>2</sup> CPC treating 2,500 m<sup>3</sup> year<sup>-1</sup> has to be washed with the same frequency, the water consumption is 2.2 litres m<sup>-3</sup> wastewater treated.

Water is also used for cooling the ozonisor. From the data supplied by Trailigaz (Perrot 2005), the ozonisor OZC 1016 consumes 2,000 litres water per kg ozone produced. According to the pilot plant experiments (Maldonado et al. 2005a; Perrot 2005), 0.8 kg ozone are effectively consumed per m<sup>3</sup> of Femac wastewater to reach the biodegradability point, and the average transfer efficiency is 50%. Therefore 3,200 litres tap water are consumed by the ozonisor per m<sup>3</sup> wastewater treated. The Ecoinvent dataset chosen for water consumption is *Tap water, at user, RER*.

#### 6.3.4.10. Transport of materials to the plant

The following table shows the transport service, in kg·km, for the corresponding transport mode, required for delivering chemicals and other materials to the wastewater treatment plant. Water is excluded from the list, as water distribution is already included in the dataset for this product (water supply network). The distances used to calculate the transport processes are the default values used by the Ecoinvent database (see section 6.2.9.5), and the datasets used are *Transport, freight, rail, RER* and *Transport, lorry 32t, RER*.

Table 6.18. Inventory of chemicals and ancillary materials transport to the plant per functional unit.

Transport mode	Fe (solar)	Ti (solar)	O3	Fe (lamp)	GAC
Transport by train (kg·km)	4,012	12	1,424	3,634	
Transport by truck (kg·km)	669	2	680	627	254

<sup>12</sup> <http://www.pilagest.es>

### 6.3.5. Solid waste management

Solid waste produced includes, on the one hand, the spent catalysts employed by the AOPs, and reactivation of spent GAC on the other.

#### 6.3.5.1. Landfilling of spent catalysts

As the mass balance must be closed, the amount of titanium or iron coming out of the AOP plant has to be the same to the amount consumed. In heterogeneous photocatalysis 200 g m<sup>-3</sup> TiO<sub>2</sub> are added, but as it is reused 10 times, only 20 g spent TiO<sub>2</sub> are produced in dry weight per m<sup>3</sup> wastewater. Iron consumed in the photo-Fenton process is not reused, therefore 20 mg Fe(II) waste are produced per m<sup>3</sup>. However, this iron was initially added as FeSO<sub>4</sub>, while in the neutralization process it is mainly precipitated as hydroxides; if Fe(OH)<sub>3</sub> is assumed as final chemical form, then 107 g Fe(OH)<sub>3</sub> are produced stoichiometrically per 56 g Fe, giving a figure of 38 g Fe(OH)<sub>3</sub> per m<sup>3</sup> wastewater. Both catalysts are obtained from the neutralization stage as a slurry, which is thickened until achieving 5% dry mass.

Table 6.19. Inventory of spent catalyst production and transport per functional unit.

Materials and processes	Fe (solar)	Ti (solar)	Fe (lamp)
Solid waste production (kg dry weight)	0.038	0.02	0.038
Solid waste production (kg wet weight)*	0.76	0.4	0.76
Transport by truck (kg km)	38	40	38
Waste composition (kg kg <sup>-1</sup> wet weight)			
- Water	0.95	0.95	0.95
- Oxygen	0.0225	0.02	
- Hydrogen	0.0015		
- Titanium		0.03	
- Iron	0.026		0.026

\* 5% dry weight.

The 5% dry mass slurry is then transported to a landfill through an average distance of 50 km, and it is mixed with cement prior to disposal. For this transport process the dataset *Transport, lorry 16t, RER* has been used. The landfilling process has been modeled using the Ecoinvent tool for landfills (Doka 2003). This model requires some data inputs in order to calculate the inventory of the landfilling process, namely the waste composition (table 6.19) and the type of landfill, which has been considered to be what the model calls “residual material landfill”<sup>13</sup>, corresponding to a facility receiving mostly inorganic waste with a varying extent of harmful contaminants.

The inventory obtained for this process, per kg catalyst, is shown in table 6.20. As can be seen, the model allocates to the treated waste the production of the landfill infrastructure<sup>14</sup>, cement processes (production, transport and disposal together with the waste), some general environmental impacts occurring in the landfill but not directly related to a specific waste type<sup>15</sup> (process-specific burdens), and finally the emission of metals to aquatic recipients in the short and long term.

<sup>13</sup> The Ecoinvent model uses the swiss terminology, according to which 3 types of landfills exist: sanitary, residual and inert landfill.

<sup>14</sup> The dataset “Residual material landfill facility” includes materials and processes for construction of 1 standard landfill. These impacts are allocated to the mass of waste to be landfilled, in landfill units per kg waste, which means that 1 kg waste is allocated the corresponding fraction of the overall landfill infrastructure.

<sup>15</sup> When allocation has to be applied to waste treatment process, frequently environmental issues are called “waste-specific” or “process-specific”. For example mercury dissolved in landfill leachate is attributable to mercury-containing waste (waste-specific).

Table 6.20. Inventory for landfilling of 1 kg spent catalyst, as obtained from the Ecoinvent tool for landfills.

Ecoinvent datasets	Fe (solar)	Ti (solar)	Fe (lamp)
<i>Residual material landfill facility, CH (units)</i>	2.08E-09	2.08E-09	2.08E-09
<i>Process-specific burdens, residual material landfill, CH (kg)</i>	1	1	1
<i>Cement unspecified, at plant, CH (kg)</i>	0.4	0.4	0.4
<i>Disposal, cement, hydrated, 0% water, to residual material landfill, CH (kg)</i>	1	1	1
<i>Transport, freight, rail, RER (kg·km)</i>	0.04	0.04	0.04
<i>Transport, lorry 28t, CH</i>	0.02	0.02	0.02
Emissions	Fe (solar)	Ti (solar)	Fe (lamp)
<i>To water, river</i>			
<i>Titanium, ion (kg)</i>		1.49E-05	
<i>Iron, ion (kg)</i>	2.18E-07		2.18E-07
<i>To groundwater, long-term</i>			
<i>Titanium, ion (kg)</i>		8.91E-03	
<i>Iron, ion (kg)</i>	1.30E-04		1.30E-04

### 6.3.5.2. Regeneration of spent activated carbon

The amount of spent GAC in dry mass to be regenerated per functional unit has been calculated in section 6.3.4.7 as 3.63 kg. However, the mass of adsorbed Femac, 0.138 kg adsorbed per kg carbon, as well as the water content of the carbon must be added. The average water content of GAC as removed from the adsorption column has been obtained from a catalan company using GAC adsorption as tertiary treatment, MASA Decor. According to this source (Domínguez 2005), spent GAC consists of 70% water and 30% carbon plus adsorbed material. Therefore, to the initial 3.63 kg dry GAC 0.5 kg Femac and 9.67 kg water must be taken into account as the mass to be transported per functional unit to the reactivation plant, which is located at an average distance of 700 km. The dataset used for this transport is *Transport, lorry, 32t, RER*.

Table 6.21. Inventory of spent GAC production and transport per functional unit.

Materials and processes	Amount
Spent GAC production (kg wet weight)	13.8
- Spent GAC production (kg dry weight)	3.63
- Femac adsorbed (kg dry weight)	0.5
- Water content (kg)	9.67
Transport by truck (kg·km)	9,660

As for GAC production, the data for reactivation is missing from the Ecoinvent database and has been obtained from literature (Meier 1997). These data (table 6.22) include the material and energy balance of the process, that according to the author (Meier 2005) were obtained directly from an industrial operator and cross-checked with an engineering company. Although the inventory data from Meier is the most detailed found, it must be acknowledged that significant differences have been found between these data and other references (AGBAR 1995; Vignes 2001; Hutchins 1975; Link and Turchi 1991; Klausner et al. 1992; Zanitsch and Stenzel 1992; USEPA 1973), namely on the amount of natural gas consumed in the process, which is typically reported in the range of 10-20 MJ/kg carbon, that is, an order of magnitude lower than the figure in table 6.22. Taking into account that a similar variability has been identified in activated carbon production, a sensitivity analysis will be carried out in order to check the influence of this uncertain parameters on the study results.

burden), while the natural gas used for heating of landfill buildings can not be directly linked to a given waste type (process-specific burden), in this case, allocation is based on the mass landfilled, regardless of its composition.



Table 6.22. Inventory for regeneration of 1 kg spent activated carbon (dry mass).

Concept	Materials and processes	Amount per kg GAC	Ecoinvent datasets used and comments
Combustion	Coal combustion (kg)	0.1	3 MJ <i>Hard coal, burned in industrial furnace 1-10 MW, RER</i> (according to Ecoinvent database the gross calorific value of hard coal is 30.4 MJ/kg)
Mixing, kiln drive	Electricity (kWh)	0.001	0.001 kWh <i>Electricity, medium voltage, production UCTE, at grid</i>
Activation	Steam (kg)	0.3	0.3 kg <i>Steam, for chemical processes, at plant, RER</i>
Heating (1000 °C, 10 hours)	Natural gas (Nm <sup>3</sup> )	2.7	108 MJ <i>Natural gas, burned in industrial furnace &gt;100kW, RER</i> (according to Ecoinvent database the gross calorific value of natural gas is 40MJ Nm <sup>-3</sup> )
Delivery of reactivated carbon	Transport by truck (kg · km)	2,542	2,542 kg · km <i>Transport, lorry 32t/RER</i>
Emission from Femac combustion	CO <sub>2</sub> (kg)	0.33	138 mg Femac per kg carbon. Stoichiometric conversion
Emission from Femac combustion	NO <sub>x</sub> (kg)	0.038	138 mg Femac per kg carbon. Stoichiometric conversion assuming NO <sub>2</sub> as final product, and no equipment for NO <sub>x</sub> removal installed.

Source: adapted from Meier (1997).

During reactivation, the adsorbed Femac is thermally destroyed, giving rise to air emissions. These have been calculated stoichiometrically from Femac composition, and considering only CO<sub>2</sub> and NO<sub>x</sub>, the latter calculated as NO<sub>2</sub>. 0.5 kg Femac are combusted per functional unit, leading to 2.4 kg CO<sub>2</sub> and 0.28 kg NO<sub>x</sub>. The furnace is assumed not to have any equipment for NO<sub>x</sub> removal. As a consequence, 100% of the NO<sub>x</sub> is emitted to the atmosphere.

On its way back to the wastewater treatment plant, the carbon is dry and the 10% losses during reactivation are replaced with new carbon. Hence only 3.63 kg carbon are transported per functional unit through the 700 km distance.

### 6.3.6. Process emissions

Emissions in the foreground system that are not already taken into account by the Ecoinvent datasets include only CO<sub>2</sub> emissions generated as a consequence of DOC degradation by the AOPs, and combustion of Femac during reactivation fo GAC, the latter being already computed in the previous section. On the other hand, the substances present in the effluent from the advanced oxidation step or from GAC adsorption are not considered at this point as emissions, since they are not yet released to the environment, but directed to a MWWTP through a sewer.

The CO<sub>2</sub> emissions associated to the advanced oxidation step are directly dependent on the DOC that must be mineralized in order to achieve the biodegradability point. These DOC targets have been set at the beginning of the inventory analysis and are used here to calculate the emissions stoichiometrically (table 6.23).

Table 6.23. CO<sub>2</sub> emissions during advanced oxidation of Femac.

Emissions	Fe (solar)	Ti (solar)	O3	Fe (lamp)
CO <sub>2</sub> (g m <sup>-3</sup> )	770	1,063	660	770

### 6.3.7. Land use

Land use is inventoried by default in the Ecoinvent datasets used, but the footprint of the plants applying either AOPs or GAC adsorption must be calculated. The Albaida plant has been used as model to account for land use by all treatments, even those not having a solar field.

The Albaida plant occupies a total area of 484 m<sup>2</sup>, of which 70 m<sup>2</sup> are used for tanks, pipes, etc., and the remaining 414 m<sup>2</sup> are occupied by the CPC field, that has a total aperture of 150 m<sup>2</sup>. If it is assumed that the area for tanks is constant and that solar field area is directly proportional to CPC aperture area, then land use per functional unit for a solar photocatalytic plant can be calculated as follows:

$$LU_{PLANT} = \frac{2.76 \cdot S_{CPC} + 70}{V} \quad (6.7)$$

Where:

$LU_{PLANT}$  is the overall land use of the plant per m<sup>3</sup> wastewater treated (m<sup>2</sup> · year m<sup>-3</sup>),

2,76 is the ratio of solar field area to CPC aperture area in the Albaida plant,

$S_{CPC}$  is the useful CPC aperture area of the plant (m<sup>2</sup>)

70 is the area used for tanks and other services (m<sup>2</sup>), and

$V$  is the yearly volume of wastewater to be treated (2,500 m<sup>3</sup> year<sup>-1</sup>).

For non-solar plants, namely those applying lamp-driven photo-Fenton, ozonation and GAC adsorption, land use is also calculated with equation 7, giving a value of zero to  $S_{CPC}$ . This implies the assumption that these plants have a footprint of 70 m<sup>2</sup>, and no difference is made between them. The  $LU_{PLANT}$  values calculated for all treatments is shown in table 6.24.

Table 6.24. Land use per functional unit associated to the AOP and GAC plants footprint.

Land use	Fe (solar)	Ti (solar)	O3	Fe (lamp)	GAC
$LU_{PLANT}$ (m <sup>2</sup> · year m <sup>-3</sup> )	0.14	2.40	0.03	0.03	0.03

### 6.3.8. Municipal Wastewater Treatment Plant

The effluent of all treatments included in the study is discharged to a public sewer and finally enters a conventional sewage plant applying primary and secondary treatment. As stated in the scope of the study, this process has been modeled by means of the Ecoinvent tool for MWWTP (Doka 2003), consisting of an excel spreadsheet that allows the composition of the wastewater to be user-defined. The model automatically calculates the inventory of the treatment process, including the sewer and MWWTP infrastructures, the use of energy, chemicals and ancillary materials, the effluent finally discharged to the environment as well as the management of the excess sludge produced.

Together with the wastewater composition, the model asks for two additional conditions to be set: first, the size of the MWWTP, that ranges from class 1 to class 5, being the former the biggest size (233,000 person equivalents/year) and the latter the smallest (806 person equivalents/year); for our simulation the middle size (class 3) has been used. The second parameter to define is the fate of the excess sludge. The model includes two possible treatments, or a user-

defined combination of both: application to agricultural soil and incineration. The choice has been to consider only incineration, since it is assumed that this is the most representative scenario for a MWWTP receiving part of its wastewater from industrial activities.

Table 6.25. Composition of the effluent entering the MWWTP.

Parameters	Fe (solar)	Ti (solar)	O3	Fe (lamp)	GAC
DOC (mg litre <sup>-1</sup> )	120	40	150	120	1.5
COD (mg litre <sup>-1</sup> )	504	214	613	504	5
N-NH4 <sup>+</sup> (mg litre <sup>-1</sup> )	27	36	23	27	0
N-organic (mg litre <sup>-1</sup> )	15	6	18	15	0.19
N-NO <sub>3</sub> <sup>-</sup> (mg litre <sup>-1</sup> )	0	0	1	0	0

The composition of the effluent entering the MWWTP (table 6.25) has been defined from the CADOX pilot plant experiments (Maldonado et al. 2005a; Passarinho and Farinha 2005) and from the laboratory tests for GAC adsorption. This composition corresponds to that of the wastewater at the point where biodegradability is reached, taking into consideration no chemical changes during the time the wastewater circulates through the sewer. Five parameters have been characterized: DOC, COD, N-NH4<sup>+</sup>, N-NO<sub>3</sub><sup>-</sup> and N-organic. Analytical data have been available for all them, with the exception of COD, which was only available for several INETI samples. In order to determine the COD values of the effluents obtained after advanced oxidation, a linear regression expressing COD as a function of DOC has been used (figure 6.13). On the other hand, the GAC effluent shows a very low DOC value (1.5 mg l<sup>-1</sup>), which is considered to be out of range for interpolation. In this case, a ratio COD/DOC = 3.6 has been used.

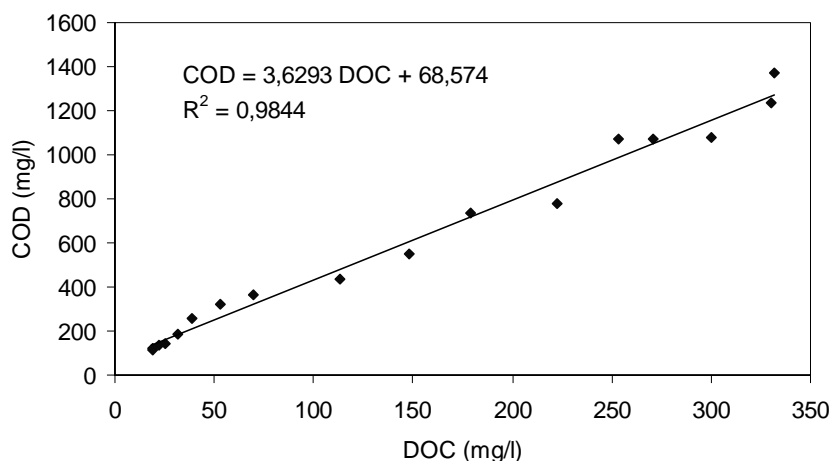

Figure 6.14. Linear regression COD vs. DOC. Source: calculated from INETI data.

### 6.3.9. Summary tables

Table 6.26 summarizes all the calculations made through sections 6.3.2 to 6.3.7, while table 6.27 presents the results of the MWWTP simulation, as explained in section 6.3.8. These tables display the Ecoinvent datasets used as well as emissions not included in the datasets, also using the Ecoinvent nomenclature. This kind of table is known as disaggregated inventory table, because it shows inputs and/or outputs to/from technosphere. All these data have been

introduced in the Simapro 6.0 software, in order to calculate all the processes, thus converting the disaggregated inventory in an aggregated inventory, which only displays environmental interventions (natural resources consumed and emissions to the environment). The aggregated inventory table is not shown, as it has more than 500 rows and can hardly be interpreted. This is the reason LCIA is applied to the inventory results in the next section, that is, to facilitate their interpretation.

Table 6.26. Disaggregated inventory table for AOPs and GAC adsorption, per functional unit, excluding MWWTP.

Processes	Fe (solar)	Ti (solar)	O3	Fe (lamp)	GAC
<b>CPC infrastructure:</b>					
Chromium steel 18/8, at plant, RER (kg)	0.021	0.45			
Steel, low-alloyed, at plant, RER (kg)	4.5E-04	9.5E-03			
Zinc coating, pieces, RER (m <sup>2</sup> )	2.7E-05	5.8E-04			
Aluminium, production mix, at plant, RER (kg)	0.026	0.55			
Section bar extrusion, aluminium, RER (kg)	0.026	0.55			
Anodising, aluminium sheet, RER (m <sup>2</sup> )	0.015	0.32			
Glass tube, borosilicate, at plant, DE (kg)	0.018	0.38			
Polypropylene, granulate, at plant, RER (kg)	3.7E-03	0.08			
Extrusion, plastic pipes, RER (kg)	5.3E-05	1.1E-03			
Injection moulding, RER (kg)	3.2E-03	0.069			
Concrete, normal, at plant, CH (m <sup>3</sup> )	8.6E-04	0.018			
Reinforcing steel, at plant, RER (kg)	0.083	1.8			
Autoclaved aerated concrete block, at plant, CH (m <sup>3</sup> )	5.3E-05	1.1E-03			
Transport, freight, rail, RER (kg·km)	38	807			
Transport, lorry 32t, RER (kg·km)	15	327			
Electricity, medium voltage, production UCTE, at grid (kWh)	0.72	18.17	21.7	14.38	0.14
Oxygen, liquid, at plant, RER (kg)			13.28		
Hydrogen peroxide, 50% in H <sub>2</sub> O, at plant, RER (kg)	1.7			1.7	
Iron sulphate, at plant, RER (kg)	0.1			0.1	
Titanium dioxide, production mix, at plant, RER (kg)		0.02			
Sulphuric acid, liquid, at plant, RER (kg)	0.13			0.13	
Sodium hydroxide, 50% in H <sub>2</sub> O, production mix, at plant, RER (kg)	0.08		0.08	0.01	
<b>GAC production:</b>					
Hard coal mix, at regional storage, RER (kg)					0.36
Hard coal, burned in industrial furnace 1-10 MW, RER (MJ)					11
Transport, lorry 32t, RER (kg·km)					218
Electricity, medium voltage, production UCTE, at grid (kWh)					7.7E-03
Hydrochloric acid, 30% in H <sub>2</sub> O, at plant, RER (kg)					15
Steam, for chemical processes, at plant, RER (kg)					1.1
Natural gas, burned in industrial furnace >100kW, RER (MJ)					71
<b>UV lamp production:</b>					
Flat glass, uncoated, at plant, RER (kg)				0.041	
Steel, low alloyed, at plant, RER (kg)				8.5E-04	
Copper, at regional storage, RER (kg)				8.5E-04	
Mercury, liquid, at plant, GLO (kg)				3.1E-06	
Tap water, at user, RER(kg)	2.19	47.01	3,200		
Transport, freight, rail, RER (kg·km)	4,012	12	1,424	4,012	
Transport, lorry 32t, RER (kg·km)	669	2	680	669	254
<b>Spent catalyst management:</b>					
Transport, lorry 16t, RER (kg·km)	38	20		38	
Residual material landfill facility, CH (units)	1.6E-09	8.3E-10		1.6E-09	
Process-specific burdens, residual material landfill, CH (kg)	0.76	0.40		0.76	
Cement unspecified, at plant, CH (kg)	0.31	0.16		0.31	
Disposal, cement, hydrated, 0% water, to residual material landfill, CH (kg)	0.76	0.40		0.76	
Transport, freight, rail, RER (kg·km)	0.031	0.016		0.031	
Transport, lorry 28t, CH	0.015	8.0E-03		0.015	
<b>Spent GAC regeneration:</b>					
Transport, lorry 32t, RER (kg·km)					9,639
Hard coal, burned in industrial furnace 1-10 MW, RER (MJ)					11
Electricity, medium voltage, production UCTE (kWh)					3.6E-03
Steam, for chemical processes, at plant, RER (kg)					1.1
Natural gas, burned in industrial furnace >100kW, RER (MJ)					392
Transport, lorry 32t, RER (kg·km)					2,542

Table 6.26. Cont.

Emissions	Fe (solar)	Ti (solar)	O3	Fe (lamp)	GAC
To air, high population density					
From DOC degradation by AOPs:					
<i>Carbon dioxide, fossil (kg)</i>	0.77	1.063	0.66	0.77	
From spent GAC regeneration:					
<i>Carbon dioxide, fossil (kg)</i>					2.4
<i>Nitrogen oxides (kg)</i>					0.28
To water, river					
From spent catalyst management:					
<i>Titanium, ion (kg)</i>		6.0E-06			
<i>Iron, ion (kg)</i>	1.7E-07			1.7E-07	
To groundwater, long-term					
From spent catalyst management:					
<i>Titanium, ion (kg)</i>		3.6E-03			
<i>Iron, ion (kg)</i>	9.9E-05			9.9E-05	
Land use	Fe (solar)	Ti (solar)	O3	Fe (lamp)	GAC
<i>Occupation, industrial site (m<sup>2</sup>·year)</i>	0.14	2.40	0.03	0.03	0.03

Table 6.27. Disaggregated inventory table for MWWTP, per functional unit.

Processes	Fe (solar)	Ti (solar)	O3	Fe (lamp)	GAC
<i>Municipal waste incineration plant, CH (units)</i>	6.7E-11	3.0E-11	8.1E-11	6.7E-11	7.8E-13
<i>Process-specific burdens, municipal waste incineration, CH (kg)</i>	2.7E-01	1.2E-01	3.2E-01	2.7E-01	3.1E-03
<i>Slag compartment, CH (units)</i>	9.1E-13	5.0E-13	1.1E-12	9.1E-13	9.3E-15
<i>Process-specific burdens, slag compartment, CH (kg)</i>	5.1E-04	2.8E-04	5.9E-04	5.1E-04	5.2E-06
<i>Residual material landfill facility, CH (units)</i>	4.1E-13	1.8E-13	5.0E-13	4.1E-13	4.9E-15
<i>Process-specific burdens, residual material landfill, CH (kg)</i>	2.0E-04	8.4E-05	2.4E-04	2.0E-04	2.4E-06
<i>Electricity from waste, at municipal waste incineration plant, CH (kWh)</i>	3.9E-02	1.7E-02	4.6E-02	3.9E-02	4.5E-04
<i>Heat from waste, at municipal waste incineration plant, CH (MJ)</i>	2.2E-01	1.0E-01	2.7E-01	2.2E-01	2.6E-03
<i>Sodium hydroxide, 50% in H<sub>2</sub>O, production mix, at plant, RER(kg)</i>	4.7E-06	5.7E-06	4.2E-06	4.7E-06	7.6E-09
<i>Quicklime, milled, packed, at plant, CH (kg)</i>	8.5E-07	1.0E-06	7.6E-07	8.5E-07	1.4E-09
<i>Hydrochloric acid, 30% in H<sub>2</sub>O, at plant, RER (kg)</i>	5.8E-09	5.2E-09	5.9E-09	5.8E-09	3.2E-11
<i>Chemicals inorganic, at plant, GLO (kg)</i>	9.6E-09	8.7E-09	9.8E-09	9.6E-09	5.4E-11
<i>Cement, unspecified, at plant, CH (kg)</i>	7.9E-05	3.4E-05	9.6E-05	7.9E-05	9.4E-07
<i>Disposal, cement, hydrated, 0% water, to residual material landfill, CH (kg)</i>	2.0E-04	8.4E-05	2.4E-04	2.0E-04	2.4E-06
<i>Transport, freight, rail, RER (tkm)</i>	2.4E-04	2.9E-04	2.2E-04	2.4E-04	4.8E-07
<i>Transport, lorry 28t, CH (tkm)</i>	5.6E-03	2.7E-03	6.8E-03	5.6E-03	3.7E-04
<i>Ammonia, liquid, at regional storehouse, CH (kg)</i>	9.4E-05	1.1E-04	8.5E-05	9.4E-05	1.5E-07
<i>Natural gas, burned in industrial furnace low-NO<sub>x</sub> &gt;100kW, RER (MJ)</i>	9.2E-03	1.1E-02	8.2E-03	9.2E-03	1.5E-05
<i>Titanium dioxide, production mix, at plant, RER (kg)</i>	2.7E-06	3.3E-06	2.4E-06	2.7E-06	4.4E-09
<i>Chromium oxide, flakes, at plant, RER (kg)</i>	5.5E-08	6.7E-08	4.9E-08	5.5E-08	9.0E-11
<i>Electricity, low voltage, at grid, CH (kWh)</i>	2.7E-01	2.5E-01	2.8E-01	2.7E-01	2.9E-02
<i>Disposal, plastics, mixture, 15.3% water, to municipal incineration, CH (kg)</i>	1.6E-02	1.6E-02	1.6E-02	1.6E-02	1.6E-02
<i>Disposal, paper, 11.2% water, to municipal incineration, CH (kg)</i>	1.6E-02	1.6E-02	1.6E-02	1.6E-02	1.6E-02
<i>Sewer grid, class 3, CH (km)</i>	2.2E-07	2.2E-07	2.2E-07	2.2E-07	2.2E-07
<i>Wastewater treatment plant, class 3, CH (units)</i>	5.7E-09	5.7E-09	5.7E-09	5.7E-09	5.7E-09
Emissions	Fe (solar)	Ti (solar)	O3	Fe (lamp)	GAC
<i>To air, high population density</i>					
<i>Heat, waste (MJ)</i>	2.9E+00	1.7E+00	3.3E+00	2.9E+00	1.3E-01
<i>NM VOC, non-methane volatile organic compounds unspecified origin (kg)</i>	7.6E-06	3.2E-06	9.2E-06	7.6E-06	9.0E-08
<i>Carbon monoxide, fossil (kg)</i>	5.4E-04	2.3E-04	6.6E-04	5.4E-04	6.5E-06
<i>Carbon dioxide, fossil (kg)</i>	6.8E-01	2.9E-01	8.2E-01	6.8E-01	8.1E-03
<i>Methane, fossil (kg)</i>	1.7E-03	7.1E-04	2.0E-03	1.7E-03	2.0E-05
<i>Nitrogen oxides (kg)</i>	5.8E-04	7.1E-04	5.2E-04	5.8E-04	9.5E-07
<i>Ammonia (kg)</i>	6.0E-05	7.2E-05	5.4E-05	6.0E-05	9.8E-08
<i>Dinitrogen monoxide (kg)</i>	1.4E-04	1.6E-04	1.3E-04	1.4E-04	3.8E-07
<i>Cyanide (kg)</i>	1.7E-06	2.0E-06	1.5E-06	1.7E-06	2.7E-09
<i>To water, river</i>					
<i>Heat, waste (MJ)</i>	3.5E+00	1.5E+00	4.3E+00	3.5E+00	4.2E-02
<i>Ammonium, ion (kg)</i>	2.0E-02	1.8E-02	2.0E-02	2.0E-02	1.1E-04
<i>Nitrogen (kg)</i>	8.8E-04	1.1E-03	7.9E-04	8.8E-04	1.4E-06
<i>BOD<sub>5</sub>, Biological Oxygen Demand (kg)</i>	3.2E-02	1.4E-02	3.9E-02	3.2E-02	3.8E-04
<i>COD, Chemical Oxygen Demand (kg)</i>	9.8E-02	4.2E-02	1.2E-01	9.8E-02	1.2E-03
<i>TOC, Total Organic Carbon (kg)</i>	1.9E-02	6.4E-03	2.4E-02	1.9E-02	2.4E-04
<i>DOC, Dissolved Organic Carbon (kg)</i>	2.4E-02	1.0E-02	3.0E-02	2.4E-02	2.9E-04
<i>Nitrate (kg)</i>	7.9E-02	7.9E-02	8.0E-02	7.9E-02	3.6E-04
<i>To groundwater, long-term</i>					
<i>BOD<sub>5</sub>, Biological Oxygen Demand (kg)</i>	4.6E-04	2.0E-04	5.6E-04	4.6E-04	5.5E-06
<i>COD, Chemical Oxygen Demand (kg)</i>	1.4E-03	6.0E-04	1.7E-03	1.4E-03	1.7E-05
<i>TOC, Total Organic Carbon (kg)</i>	5.6E-04	2.4E-04	6.8E-04	5.6E-04	6.7E-06
<i>DOC, Dissolved Organic Carbon (kg)</i>	5.6E-04	2.4E-04	6.8E-04	5.6E-04	6.7E-06
<i>Nitrate (kg)</i>	6.7E-05	8.1E-05	6.0E-05	6.7E-05	1.1E-07

## 6.4. Life Cycle Impact Assessment for Baseline Alternatives

Section 6.4 is devoted to the interpretation of the inventory results through the application of LCIA. First, in 6.4.1 a contribution analysis is performed in order to identify the critical issues for each treatment. This is followed in 6.4.2 by a comparative assessment of all the AOPs and GAC adsorption. All the LCIA results are displayed graphically; the numeric data on which the graphics are based can be found in appendix 4.

### 6.4.1. Contribution analysis

Contribution analysis is aimed at identifying the critical sub-systems or “hot-spots” for each alternative. For this purpose the results of characterisation are used, disaggregating them so that the contribution of the different processes can be analysed. The type of graphics used through sections 6.4.1.1 to 6.4.1.5 are equivalent to those used in the contribution analysis performed in chapter 5: the overall score for each impact indicator (kg eq. CO<sub>2</sub>, for example) are expressed as 100%, being the contribution of a sub-system a fraction of this figure; each bar in the graphic then can be considered as equivalent to a single pie chart.

#### 6.4.1.1. Solar-driven photo-Fenton

Figure 6.15 shows the environmental profile of solar-driven photo-Fenton coupled to biological treatment. Several sub-systems, namely sulphuric acid, sodium hydroxide and ferrous sulphate production, cleaning water and iron sludge management are grouped together under the heading “others”, due to their low individual contribution to all impacts. This figure is based on data displayed in table 6.A.10 of appendix 4.

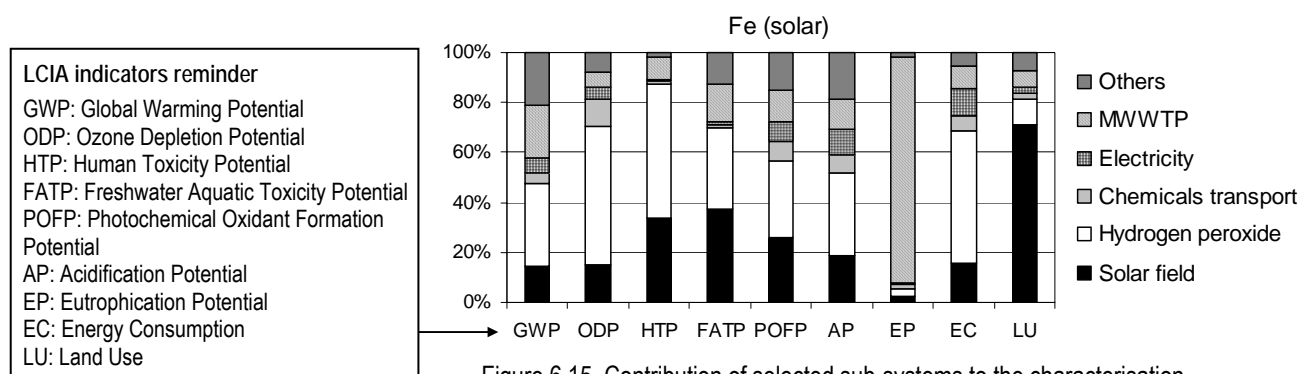

Figure 6.15. Contribution of selected sub-systems to the characterisation results of solar-driven photo-Fenton coupled to biological treatment.

As can be seen, three sub-systems are responsible of the major contributions: on the one hand the solar field (CPC production and terrain preparation) is responsible of 30-40% of the toxicity potentials (HTP,FATP) and 70% of land use (LU), the latter including land for materials production and the plant footprint. On the other hand, hydrogen peroxide is the major contributor to all impacts, except land use and eutrophication (EP). This is attributed to the fact that it is the main auxiliary material for plant operation. The eutrophication indicator is dominated by the sewage plant (90% of total contribution). This is caused by the remaining nitrogen compounds discharged in the MWWTP effluent to the aquatic recipient, mostly ammonium and nitrate. The MWWTP model considered include nitrification, but denitrification only to a limited extent, thus part of the ammonium entering the sewage plant is converted to nitrate and then released to the water stream. Finally, the contribution of electricity consumed during operation and delivery of chemicals to the plant,



although not critical, is not negligible; these sub-systems account altogether for 15% of ozone depletion (ODP), acidification (AP) and energy consumption (EC).

#### 6.4.1.2. Solar-driven heterogeneous photocatalysis

Figure 6.16. shows the environmental profile of TiO<sub>2</sub>-based photocatalysis coupled to biological treatment. As can be seen, only three sub-systems are responsible together for more than 95% of the total impact in all indicators. Under the heading “others”, that accounts for less than 5% of the overall impact, the following processes are included: TiO<sub>2</sub> production and transport, water for CPCs cleaning and management of spent TiO<sub>2</sub> as waste. This figure is based on data displayed in table 6.A.11 of appendix 4.

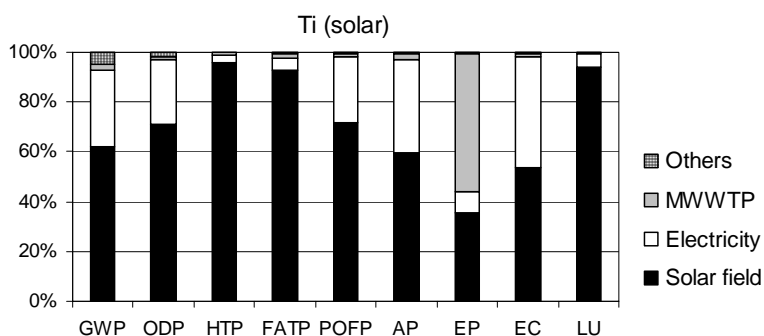

Figure 6.16. Contribution of selected sub-systems to the characterisation results of solar-driven heterogeneous photocatalysis coupled to biological treatment.

Production of the infrastructure is the most critical issue in heterogeneous photocatalysis, due to the huge CPC aperture area needed by the plant (2,150 m<sup>2</sup>). As an example, this subsystem accounts for more than 90% in the toxicity indicators (HTP, FATP) and land use (LU). This means that the initial impact of building the plant and its components has a higher environmental impact than the accumulated operation activities during 15 years of useful life. The second issue to highlight is the electricity consumed by the plant, which is responsible of up to 45% of the life cycle energy consumed (EC). 75% of the electricity consumed is used for pumping, as the huge solar field requires considerable power (near 8 kW) to recirculate the water through it. The remaining 25% electricity is consumed by microfiltration of the catalyst supernatant, a rather energy-intensive process. Finally, the sewage plant treating the effluent from the advanced oxidation step is responsible of more than 50% of the eutrophication potential (EP), for the same reason explained in the photo-Fenton case, that is, the remaining nitrogen in the MWWTP effluent.

#### 6.4.1.3. Ozonation

The environmental profile of ozonation coupled to biological treatment is shown in figure 6.17, displaying four sub-systems and the category “others”, which includes two sub-systems with a relatively low contribution to the overall impact: sodium hydroxide production and transport of chemicals to the plant. This figure is based on data displayed in table 6.A.12 of appendix 4.

It can be seen from the graphic that the highest contribution (from 40 to 60% depending on the indicator) except in eutrophication (EP), comes from producing the electricity consumed by the plant; 90% of this electricity is related to the ozoniser, that is, to ozone production, while the remaining 10% is consumed for pumping. Production of oxygen is another important sub-system, as it is used in considerable amounts; it contributes to 20-30% of the overall impact in

most indicators. Also remarkable is the contribution of water, the impact of which comes from the water works and further distribution. Water is consumed in relatively big volumes to cool the ozoniser, being responsible of 14% of toxicity potentials (HTP, FATP) and 28% of land use (LU). As in the previous AOPs analyzed, the eutrophication potential is dominated (80%) by the treated effluent generated at the MWWTP.

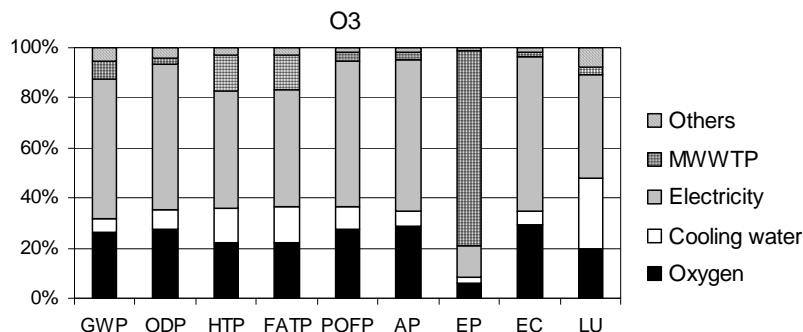

Figure 6.17. Contribution of selected sub-systems to the characterisation results of ozonation coupled to biological treatment.

#### 6.4.1.4. Lamp driven photo-Fenton

Figure 6.18 displays the environmental profile of lamp-driven photo-Fenton coupled to biological treatment. There are three highlighted sub-systems, while the remaining are grouped into the “others” category, including lamp production, ferrous sulphate, sulphuric acid and sodium hydroxide production, transport of chemicals and management of iron sludge. This figure is based on data displayed in table 6.A.13 of appendix 4.

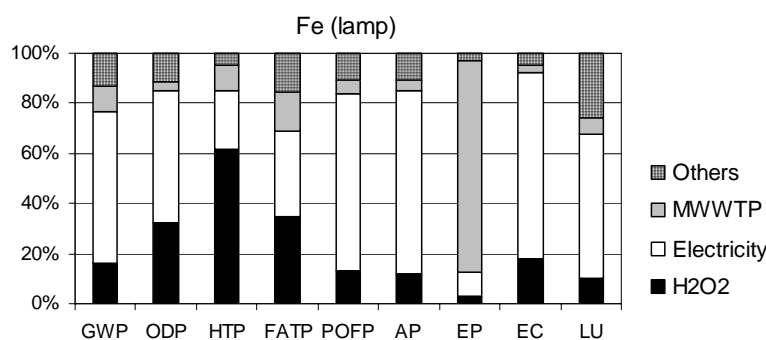

Figure 6.18. Contribution of selected sub-systems to the characterisation results of lamp-driven photo-Fenton coupled to biological treatment.

The most critical sub-system in most impact categories is electricity consumed by the advanced oxidation step, contributing, for example, to 60% of global warming potential (GWP), 70% of acidification potential (AP) and to 75% of energy consumption (EC). 90% of this electricity consumed by the plant corresponds to lamp irradiation, while the remaining 10% is associated to pumping and stirring. As in solar-driven photo-Fenton, the contribution of hydrogen peroxide is also of great importance. In fact, both processes consume the same amount of this chemical, that is responsible of 60% of human toxicity potential (HTP) and 35% of ecotoxicity potential (FATP). Once again, the MWWTP is the main contributor to eutrophication (85%) due to nitrogen discharged in the final effluent.

#### 6.4.1.5. Activated carbon adsorption

The environmental profile of GAC adsorption is displayed in figure 6.19. This figure is based on data displayed in table 6.A.14 of appendix 4. As can be seen, the main environmental impact is associated to carbon regeneration, namely to the fuel requirements for heating the furnace and steam production although these details are not shown in the figure. GAC regeneration is responsible for about 80% in several indicators, such as global warming potential (GWP), ozone depletion potential (ODP), acidification potential (AP) and also eutrophication potential (EP). Related to the latter, it is highlighted that the nitrogen contained in Femac is not released in the aquatic effluent of the MWWTP, but in the regeneration furnace emissions, in the form of NO<sub>x</sub>; for this reason, the contribution of the MWWTP to eutrophication is very low. Production of GAC, the main ancillary material, has not a critical contribution in most of the impacts (from 4% to 40% depending on the indicator), except land use (LU). This is due to the fact that it is regenerated, and only the losses during transport and regeneration must be replaced. Finally, the “others” category includes several transport steps as well as electricity consumption for pumping, a group of processes with low contributions in all indicators.

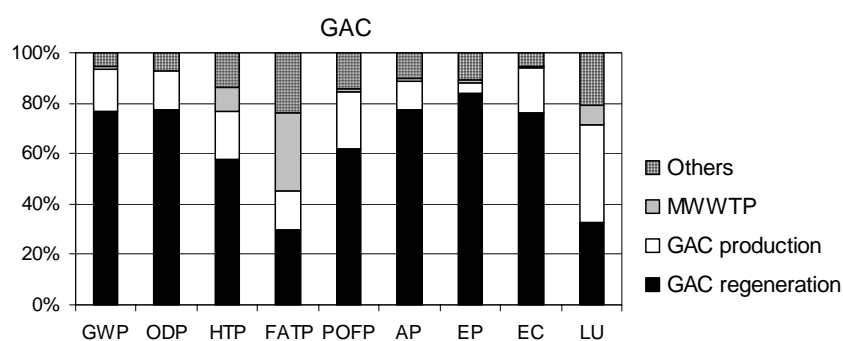

Figure 6.19. Contribution of selected sub-systems to the characterisation results of GAC adsorption.

These results have been obtained by using inventory data on GAC production and regeneration which have been found to significantly differ with regard to other literature references. Due to this uncertainty, a sensitivity analysis will be carried out in order to check the influence of the inventory data on the environmental profile of GAC adsorption.

#### 6.4.2. Comparative assessment

After analyzing the main sources of environmental impacts for all alternatives, they are compared in this section to each other in order to determine their environmental performance in each LCIA indicator. This is done in figure 6.209, showing the characterisation results for the five treatment options. The most impacting treatment is represented as 100% for each indicator.

Several aspects must be discussed from figure 6.20. With regard to AOPs, the poor environmental performance of heterogeneous photocatalysis must be highlighted. It is overall the worst option among the four AOPs, presenting the highest score in all indicators. These results show that using solar light as a source of photons is not always justified: the degradation of Femac is so slow by TiO<sub>2</sub>-based photocatalysis that a huge solar field must be erected, giving rise to higher environmental impacts than applying lamp-driven photo-Fenton, an option that would be in principle judged as less environmentally friendly. However, when the same AOP is compared on the basis of using natural (solar) or artificial light, as has been done for photo-Fenton, it is observed in general terms that solar light is preferable: global warming and

photo-oxidant formation (POFP) is twofold for the lamp alternative, and threefold in energy consumption (EC) as well as acidification (AP).

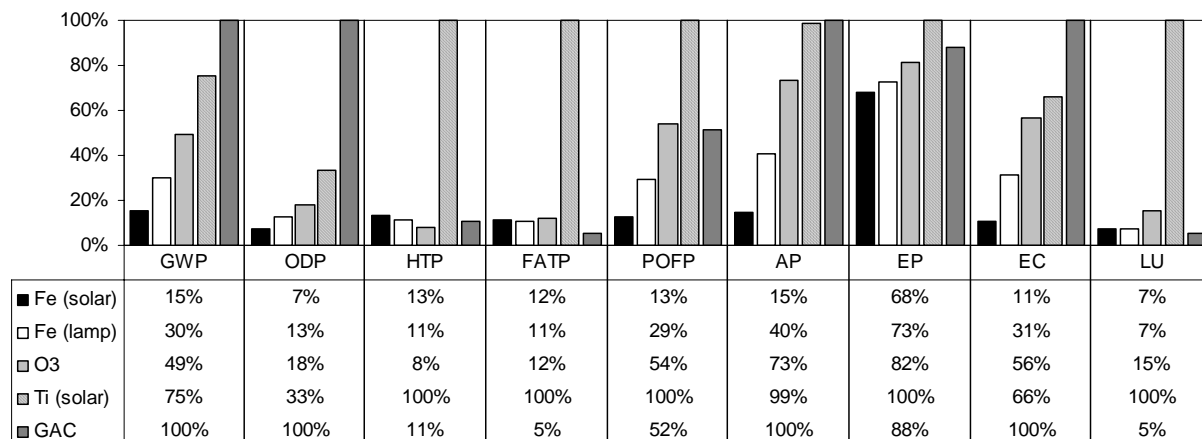

Figure 6.20. Characterisation results for all alternatives, relative to the most impacting treatment per indicator.

If heterogeneous photocatalysis is not taken into account, the remaining AOPs display smaller differences between each other. Solar photo-Fenton seems to be the best option in all indicators except human toxicity, where ozonation scores better. With this exception, ozonation appears to have worse results than photo-Fenton, be it run either by lamps or by the sun.

When the AOPs are compared to the reference technology, GAC adsorption, they present themselves as attractive alternatives from an environmental point of view, if heterogeneous photocatalysis is not counted here. With the exception of land use (LU) and ecotoxicity (FATP), the other three AOPs score better than GAC in all indicators. It has to be highlighted that GAC adsorption has been assessed under the best possible scenario, namely regeneration, whereby only small amounts of carbon are consumed. The differences in environmental impact would probably be more important if GAC was sent to incineration, as the amount of carbon that must be consumed is 10 times higher. It has to be borne in mind, however, that inventory data for GAC production and regeneration is rather variable from one literature source to another. Therefore, in order to check the robustness of these results, the performance of AOPs with regard to GAC adsorption is assessed again in the next section, where a sensitivity analysis is carried out concerning the GAC inventory data.

Finally, two indicators deserve a particular observation. The first one is eutrophication (EP), where the differences between treatments are very low, as compared to other indicators. This is caused by the nitrogen present in the Femac molecule: all treatments treat the same amount of Femac, and therefore release more or less the same amount of nitrogen to the environment, be it in the MWWTP effluent or in the GAC regeneration furnace. Finally, a remark has to be made on land use. One of the drawbacks of using solar light, whatever the purpose, is the area needed to collect the energy. However, the application of solar-driven photo-Fenton for treatment of Femac shows that in a life cycle perspective, the amount of land used per functional unit is in the range of non-solar alternatives.

## 6.5. Sensitivity Analysis on Activated Carbon Production and Regeneration

In order to use LCA as a tool for decision making, information is needed on the robustness of the results. In a sensitivity analysis, the influence on the results of variations in process data, model choices, or other variables is assessed (Guinée et al. 2002). These parameters are changed in order to observe to what extent differences appear as compared to the original results.

This sensitivity analysis is concerned with the inventory data used to model GAC production and regeneration. As GAC from bituminous coal is not currently included in the Ecoinvent database, data from a detailed swiss study (Meier 1997) has been used in the baseline inventory. However, since significant differences are found with regard to other published studies, in section 6.5.1 an alternative inventory on GAC production and regeneration is built, while in section 6.5.2 the associated LCIA results are discussed.

### 6.5.1. Inventory analysis

This inventory analysis focuses on the data used to model GAC production and regeneration. All the remaining parameters of the GAC adsorption alternative, such as amount of carbon required per functional unit, transport operations (from the manufacturer to the user, from the user to the reactivation plant, etc.) or electricity consumption for pumping in the WWTP, remain unaltered and are not discussed again.

#### 6.5.1.1. GAC production

Only two alternative references have been found in which an inventory of GAC production is detailed (Romero-Hernández 2004a; Bayer et al. 2005). It has been decided to use the data by Bayer and coworkers (2005), as the inventory by Romero-hernández (2004a), in addition to coal, considers wood and coke as raw materials.

Table 6.28. Alternative inventory for production of 1 kg activated carbon.

Concept	Materials and processes	Amount per kg GAC	Ecoinvent datasets used and comments
Raw material	Crude coal (kg)	3	1 kg <i>Hard coal mix, at regional storage, RER + 60.8 MJ Hard coal, burned in industrial furnace 1-10 MW, RER</i> (according to Ecoinvent database the gross calorific value of hard coal is 30.4 MJ/kg)
GAC production facility	Electricity (kWh)	1.6	1.6 kWh <i>Electricity, medium voltage, production UCTE, at grid</i>
Activation	Water for steam (kg)	12	12 kg <i>Water, deionised, at plant, CH</i>
Steam heating	Natural gas (Nm <sup>3</sup> )	0.33	13.2 MJ <i>Natural gas, burned in industrial furnace &gt;100kW, RER</i> (according to Ecoinvent database the gross calorific value of natural gas is 40MJ Nm <sup>-3</sup> )

Source: adapted from Bayer and coworkers (2005).

If the data from table 6.28 is compared to the initial data on GAC production (table 6.16), the main differences are the following: the amount of raw material in order to obtain 1 kg GAC is now 50% higher, a figure in accordance with Romero-Hernández (2004a); transport from the mine to the GAC production plant is excluded, as well as hydrochloric

acid for washing of carbonates; the electricity requirements are remarkably higher, and also the amount of water to produce steam. On the other hand, the heat requirements are an order of magnitude lower and refer only to steam production, not to direct furnace heating.

### 6.5.1.2. Activated carbon regeneration

One of the main the main environmental burdens of the regeneration process is the energy consumed in the form of natural gas. According to Meier (1997), 2.7 Nm<sup>3</sup> of this fuel are consumed per kg dry carbon, that is 108 MJ (considering the Ecoinvent figure of 40 MJ Nm<sup>-3</sup> gas). In table 6.29 alternative values found in other sources are displayed. As can be seen, usual figures are an order of magnitude lower, in the 10-20 MJ kg<sup>-1</sup> range. Data for the remaining energy inputs to the process, namely steam and electricity, are rather scarce.

Table 6.29. Alternative energy consumption figures found in the literature for reactivation of 1 kg spent activated carbon (dry mass).

Energy input	Units	Source	Comments
<b>Natural gas</b>			
11.5	MJ	AGBAR (1995)	92,000 MJ for daily treating 8,000 kg carbon
16.3	MJ	Vignes (2001)	7,000 btu lb <sup>-1</sup> carbon
10.5	MJ	Hutchins (1975)	4,500 btu lb <sup>-1</sup> carbon for a facility treating 10,000 lb day <sup>-1</sup>
11.6	MJ	Link and Turchi (1991)	5,000 btu lb <sup>-1</sup> carbon
20.6	MJ	Klausner et al. (1992)	Several figures are given; 20.6 MJ kg <sup>-1</sup> corresponds to a multiple hearth furnace, which is the most common technology
18.6	MJ	Zanitsch and Stenzel (1978)	8,000 btu lb <sup>-1</sup> carbon
9.9	MJ	USEPA (1973)	4,250 btu lb <sup>-1</sup> , excluding gas consumption in the afterburner
<b>Electricity</b>			
0.22	kWh	Vignes (2002)	0.1 kWh lb <sup>-1</sup> carbon
0.03	kWh	Hutchins (1975)	0.015 kWh lb <sup>-1</sup> carbon
<b>Steam</b>			
0.6	kg	Hutchins (1975)	0.6 lb lb <sup>-1</sup> carbon

In the sensitivity analysis it has been decided to use the data by Hutchins (1975), as it is the most complete; these data was also used by Romero-Hernández (2004a) in his case study. Table 6.30 shows the alternative inventory data for the reactivation process. As can be seen, some parameters remain unchanged with regard to the original inventory, such as the transport of the reactivated carbon back to the plant using GAC, and the emissions generated by combustion of Femac in the furnace. Concerning carbon losses in the reactivation process, the initial figure of 10% is also kept unchanged, as this value is the standard used in all references.

Table 6.30. Alternative inventory for regeneration of 1 kg spent activated carbon (dry mass).

Concept	Materials and processes	Amount per kg GAC	Ecoinvent datasets used and comments
Combustion	Coal combustion (kg)	0.1	3 MJ <i>Hard coal, burned in industrial furnace 1-10 MW, RER</i> (according to Ecoinvent database the gross calorific value of hard coal is 30.4 MJ/kg)
Reactivation facility	Electricity (kWh)	0.03	0.03 kWh <i>Electricity, medium voltage, production UCTE, at grid</i>
Activation	Steam (kg)	0.6	0.6 kg <i>Steam, for chemical processes, at plant, RER</i>
Heating	Natural gas (MJ)	10.5	10.5 MJ <i>Natural gas, burned in industrial furnace &gt;100kW, RER</i> (according to Ecoinvent database the gross calorific value of natural gas is 40MJ Nm <sup>-3</sup> )
Delivery of reactivated carbon	Transport by truck (kg · km)	2,542	2,542 kg · km <i>Transport, lorry 32t/RER</i>
Emission from Femac combustion	CO <sub>2</sub> (kg)	0.33	138 mg Femac per kg carbon. Stoichiometric conversion
Emission from Femac combustion	NO <sub>x</sub> (kg)	0.038	138 mg Femac per kg carbon. Stoichiometric conversion assuming NO <sub>2</sub> as final product, and no equipment for NO <sub>x</sub> removal installed.

Source: adapted from Hutchins (1975).

### 6.5.1.3. Summary table

Table 6.31 summarizes the alternative disaggregated inventory table for GAC adsorption. This table is an equivalent for table 6.26: it shows the Ecoinvent datasets used as well as emissions not included in the datasets, also using the Ecoinvent nomenclature. The inventory corresponding to further treatment of the effluent in the MWWTP is not shown here, as there are no changes in this process with regard to the original data.

Table 6.31. Alternative disaggregated inventory table for GAC adsorption, per functional unit, excluding MWWTP.

Processes	GAC
<i>Electricity, medium voltage, production UCTE, at grid (kWh)</i>	0.14
GAC production:	
<i>Hard coal mix, at regional storage, RER (kg)</i>	0.36
<i>Hard coal, burned in industrial furnace 1-10 MW, RER (MJ)</i>	22
<i>Electricity, medium voltage, production UCTE, at grid (kWh)</i>	0.58
<i>Natural gas, burned in industrial furnace &gt;100kW, RER (MJ)</i>	4.8
<i>Water, deionised, at plant, CH (kg)</i>	4.4
<i>Transport, lorry 32t, RER (kg · km)</i>	254
Spent GAC regeneration:	
<i>Transport, lorry 32t, RER (kg · km)</i>	9,639
<i>Hard coal, burned in industrial furnace 1-10 MW, RER (MJ)</i>	11
<i>Electricity, medium voltage, production UCTE (kWh)</i>	0.12
<i>Steam, for chemical processes, at plant, RER (kg)</i>	2.2
<i>Natural gas, burned in industrial furnace &gt;100kW, RER (MJ)</i>	38
<i>Transport, lorry 32t, RER (kg · km)</i>	2,542
Emissions	GAC
To air, high population density	
From spent GAC regeneration:	
<i>Carbon dioxide, fossil (kg)</i>	2.4
<i>Nitrogen oxides (kg)</i>	0.28
Land use	GAC
<i>Occupation, industrial site (m<sup>2</sup> · year)</i>	0.03

## 6.5.2. Life Cycle Impact Assessment

The LCIA results obtained for GAC adsorption in the sensitivity analysis are discussed below, at two levels: first, the contribution analysis is carried out, and next the AOPs are compared to GAC.

### 6.5.2.1. Contribution analysis

Figure 6.21 shows the environmental profile of GAC adsorption after substituting the original data by Meier (1997) with alternative data. This figure is based on data displayed in table 6.A15 in appendix 4.

If figure 6.21 is compared to figure 6.19, where the original environmental profile is shown, it can be seen that the relative importance of carbon regeneration has decreased in general. Its maximum contributions are found in eutrophication potential (EP) (80%) and acidification potential (AP) (70%), due to the NO<sub>x</sub> emissions generated by Femac combustion. In the remaining categories, contributions range from 15% to 50%. On the other hand, the relative impacts of carbon production remarkably increase: in figure 6.19 contributions ranged from 4% to 40% depending on the indicator considered, while in figure 6.21 this range is from 8% to 55%. The MWWTP and the category “others”, including several transport steps and electricity consumption for pumping, also moderately increase their contribution in all indicators.

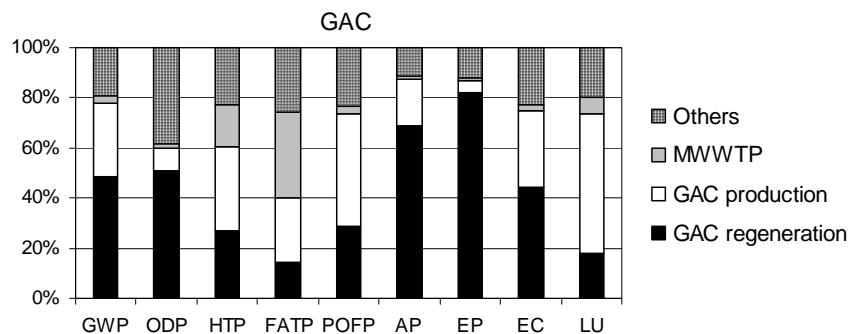

Figure 6.21. Contribution of selected sub-systems in the characterisation results of the GAC adsorption sensitivity analysis.

### 6.5.2.2. Comparative assessment

Figure 6.22 displays the comparative results of all alternatives under study, as they were in figure 6.20. In addition of the original results for the GAC alternative, figure 6.22 also displays the results for this alternative as obtained in the sensitivity analysis, GAC (S.A.).

First of all, the notable decrease in environmental impact registered by GAC adsorption in the sensitivity analysis must be highlighted. Some examples are ozone depletion potential (ODP), which is 80% lower, and global warming potential (GWP) and energy consumption (EC), which are 70% and 75% lower respectively. Impact reduction in other indicators are also remarkable, such as human toxicity potential (HTP) and oxidant formation potential (POFP), which are reduced by 40%. The main reason explaining this improvement in environmental performance is the natural gas consumption of the reactivation process, considered to be an order of magnitude lower in the sensitivity analysis.



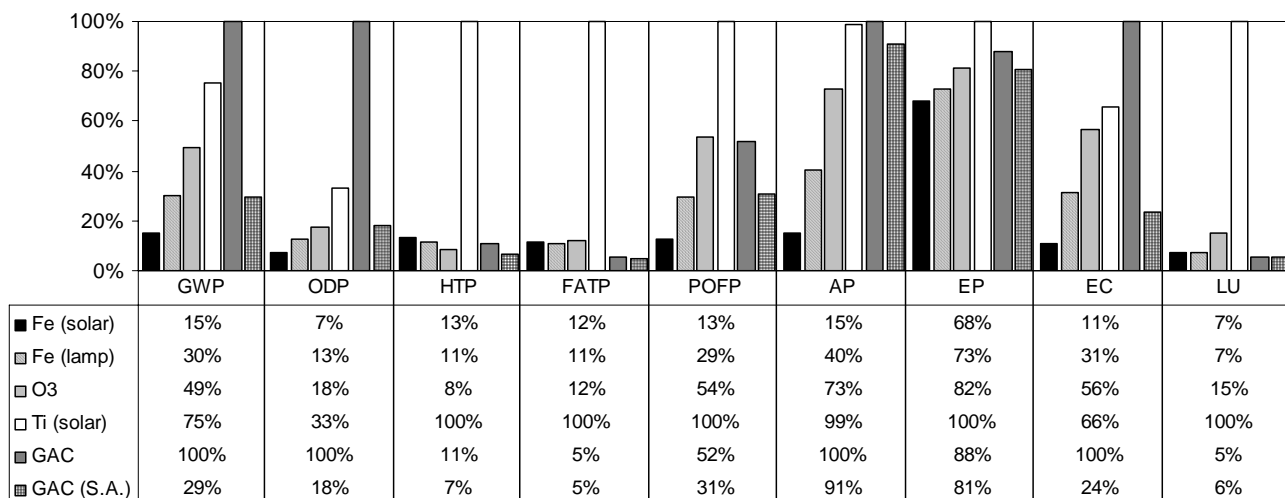

Figure 6.22. Characterisation results for all alternatives, relative to the most impacting treatment per indicator. GAC (S.A.): characterisation results of the sensitivity analysis on GAC adsorption.

When the AOPs are compared to the GAC results obtained in the sensitivity analysis the picture changes with regard to the initial comparison in section 6.4.2. Ozonation can not be clearly considered to rank better than GAC (S.A.), as the latter performs better in 5 impact categories, and something similar happens with lamp-driven photo-Fenton. With regard to solar-driven photo-Fenton, it still performs better than GAC (S.A.) and the other AOPs in 6 impact categories.

## 6.6. Environmental Impact of Solar Photocatalysis as a Function of UV Light Available

As pointed in section 6.2.6, where the baseline scenario is defined, solar-driven AOPs have been assessed in the present study according to the local conditions of Almería, a privileged region in Europe in terms of solar resources. The question that arises is how the environmental impact of solar AOPs would vary if they were applied in less favorable locations. This section is intended to give an answer to this question, by means of a sensitivity analysis in which the solar UV resources of other European regions or cities are considered. This analysis is only performed on solar photo-Fenton, as it has been found to be more attractive from an environmental point of view than heterogeneous photocatalysis.

### 6.6.1. Environmental implications of lower UV available

Solar photocatalytic degradation of a pollutant depends, among other parameters, on  $Q_{UV}$ , the accumulated UV radiation needed per unit wastewater volume. For example, the pilot plant experiments carried out at PSA found that, in order to reach biodegradability, 12 kJ UV light must be irradiated per litre Femac wastewater. As it has been calculated in the inventory analysis, a CPC field having 100 m<sup>2</sup> aperture can treat 2,500 m<sup>3</sup> per year... as long as it is located in Almería. If this same CPC field is moved to northern Europe, where less solar radiation is available, it will not be possible to treat 2,500 m<sup>3</sup> year<sup>-1</sup>, because it has not enough aperture area to collect the  $3 \times 10^7$  kJ UV required per year. Hence, if the same yearly flow is to be treated, the dimension of the CPC field has to increase.

In this sensitivity analysis it is assumed that CPC aperture area is inversely proportional to solar UV irradiation available ( $UV_G$ ), whereby if  $UV_G$  decreases to half the value in Almería, twofold CPC area will be needed. From an environmental point of view, the following consequences have been taken into account when increasing the solar field:

- The plant footprint increases,
- Material requirements for plant infrastructure (materials for CPCs, concrete for terrain paving, etc.) increase, and
- Power consumption for recirculation of wastewater increases.

Water consumed for periodic cleaning of the CPCs also increases. Nevertheless, this has not been taken into account due to its relatively low environmental relevance, as determined by the contribution analysis. All the remaining parameters, such as consumption of chemicals, spent catalyst management or treatment of the effluent in the MWWTP remain unchanged.

### 6.6.2. Inventory analysis

The three parameters identified above as influenced by  $UV_G$  have been recalculated with the corresponding equations, for a range of  $UV_G$  values from 5 to 30 W m<sup>-2</sup>. The results of these calculations are shown in table 6.328. From these new values, a new inventory table is built (table 6.33), showing the Ecoinvent datasets used as well as emissions not included in the datasets, also using the Ecoinvent nomenclature. The inventory corresponding to further treatment of the advanced oxidation effluent in the MWWTP is not shown here, since this process is independent of  $UV_G$ .

Table 6.32. Calculation of parameters affected by UV radiation available in a solar-driven photo-Fenton plant.

Parameter	Equation	$UV_G$ (W m <sup>-2</sup> )					
		5	10	15	20	25	30
$S_{CPC}$ (m <sup>2</sup> )	2	373	186	124	93	75	62
$LU_{PLANT}$ (m <sup>2</sup> y/m <sup>3</sup> )	3	0.44	0.23	0.17	0.13	0.11	0.097
$EPUMP$ (kWh/m <sup>3</sup> )	7	2.39	1.20	0.8	0.60	0.48	0.40

Table 6.33. Disaggregated inventory table for solar-driven photo-Fenton, excluding MWWTP and considering different  $UV_G$  values.

Processes	$UV_G$ (W m <sup>-2</sup> )					
	5	10	15	20	25	30
<b>CPC infrastructure:</b>						
<i>Chromium steel 18/8, at plant, RER (kg)</i>	0.078	0.039	0.026	0.019	0.016	0.013
<i>Steel, low-alloyed, at plant, RER (kg)</i>	1.7E-03	8.3E-04	5.5E-04	4.1E-04	3.3E-04	2.8E-04
<i>Zinc coating, pieces, RER (m<sup>2</sup>)</i>	1.0E-04	5.1E-05	3.4E-05	2.5E-05	2.0E-05	1.7E-05
<i>Aluminium, production mix, at plant, RER (kg)</i>	0.096	0.048	0.032	0.024	0.019	0.016
<i>Section bar extrusion, aluminium, RER (kg)</i>	0.096	0.048	0.032	0.024	0.019	0.016
<i>Anodising, aluminium sheet, RER (m<sup>2</sup>)</i>	0.055	0.028	0.018	0.014	0.011	0.009
<i>Glass tube, borosilicate, at plant, DE (kg)</i>	0.067	0.033	0.022	0.017	0.013	0.011
<i>Polypropylene, granulate, at plant, RER (kg)</i>	1.4E-02	6.9E-03	4.6E-03	3.5E-03	2.8E-03	2.3E-03
<i>Extrusion, plastic pipes, RER (kg)</i>	2.0E-04	9.9E-05	6.6E-05	5.0E-05	4.0E-05	3.3E-05
<i>Injection moulding, RER (kg)</i>	1.2E-02	6.0E-03	4.0E-03	3.0E-03	2.4E-03	2.0E-03
<i>Concrete, normal, at plant, CH (m<sup>3</sup>)</i>	3.2E-03	1.6E-03	1.1E-03	8.0E-04	6.4E-04	5.3E-04
<i>Reinforcing steel, at plant, RER (kg)</i>	0.310	0.155	0.103	0.078	0.062	0.052
<i>Autoclaved aerated concrete block, at plant, CH (m<sup>3</sup>)</i>	2.0E-04	9.9E-05	6.6E-05	5.0E-05	4.0E-05	3.3E-05
<i>Transport, freight, rail, RER (kg·km)</i>	140	70	47	35	28	23
<i>Transport, lorry 32t, RER (kg·km)</i>	57	28	19	14	11	9
<i>Electricity, medium voltage, production UCTE, at grid (kWh)</i>	2.47	1.28	0.88	0.68	0.56	0.48
<i>Hydrogen peroxide, 50% in H<sub>2</sub>O, at plant, RER (kg)</i>	1.7	1.7	1.7	1.7	1.7	1.7
<i>Iron sulphate, at plant, RER (kg)</i>	0.1	0.1	0.1	0.1	0.1	0.1
<i>Sulphuric acid, liquid, at plant, RER (kg)</i>	0.13	0.13	0.13	0.13	0.13	0.13
<i>Sodium hydroxide, 50% in H<sub>2</sub>O, production mix, at plant, RER (kg)</i>	0.08	0.08	0.08	0.08	0.08	0.08
<i>Tap water, at user, RER(kg)</i>	2.19	2.19	2.19	2.19	2.19	2.19
<i>Transport, freight, rail, RER (kg·km)</i>	4012	4012	4012	4012	4012	4012
<i>Transport, lorry 32t, RER (kg·km)</i>	669	669	669	669	669	669
<b>Spent catalyst management:</b>						
<i>Transport, lorry 16t, RER (kg·km)</i>	38	38	38	38	38	38
<i>Residual material landfill facility, CH (units)</i>	1.6E-09	1.6E-09	1.6E-09	1.6E-09	1.6E-09	1.6E-09
<i>Process-specific burdens, residual material landfill, CH (kg)</i>	0.76	0.76	0.76	0.76	0.76	0.76
<i>Cement unspecified, at plant, CH (kg)</i>	0.31	0.31	0.31	0.31	0.31	0.31
<i>Disposal, cement, hydrated, 0% water, to residual material landfill, CH (kg)</i>	0.76	0.76	0.76	0.76	0.76	0.76
<i>Transport, freight, rail, RER (kg·km)</i>	0.031	0.031	0.031	0.031	0.031	0.031
<i>Transport, lorry 28t, CH</i>	0.015	0.015	0.015	0.015	0.015	0.015
<b>Emissions</b>						
<b>To air, high population density</b>						
<b>From DOC degradation by AOPs:</b>						
<i>Carbon dioxide, fossil (kg)</i>	0.77	0.77	0.77	0.77	0.77	0.77
<b>To water, river</b>						
<b>From spent catalyst management:</b>						
<i>Iron, ion (kg)</i>	1.7E-07	1.7E-07	1.7E-07	1.7E-07	1.7E-07	1.7E-07
<b>To groundwater, long-term</b>						
<b>From spent catalyst management:</b>						
<i>Iron, ion (kg)</i>	9.9E-05	9.9E-05	9.9E-05	9.9E-05	9.9E-05	9.9E-05
<b>Land use</b>						
<i>Occupation, industrial site (m<sup>2</sup>·year)</i>	0.44	0.23	0.17	0.13	0.11	0.097

### 6.6.3. Estimation of solar UV resources in several european locations

Once  $UV_G$  is known for a given location, the environmental impact of solar photo-Fenton can be determined from the data in the inventory analysis. However,  $UV_G$  values are not as readily available from statistics as other solar-related parameters such as number of sunny hours per year or global solar radiation. According to Blanco (2002), UV radiation represents between 3.5 and 8% of the solar spectrum, fluctuating with the presence of clouds and increasing with altitude. In this way, UV radiation for different european locations can be estimated by assuming that  $UV_G$  equals in average about 5% of global solar radiation. Table 6.30 shows the data used for several sites in EU countries, encompassing a wide range of latitudes, from the very low at the Canary Islands to the highest in northern Sweden (figure 6.23).

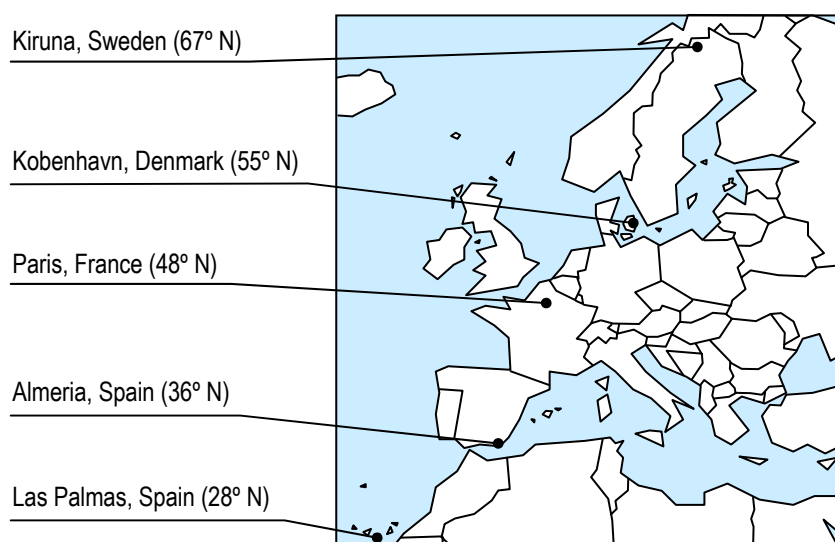

Figure 6.23. EU sites for which  $UV_G$  values are estimated.

Average global solar radiation data for these sites in  $kWh\ m^{-2}\ day^{-1}$  have been obtained from PVGIS (EU 2005), a Geographic information system containing an inventory of solar resources in Europe and Africa. This estimation has also been applied to the city of Almeria, and it can be seen that the value obtained ( $22\ W\ m^{-2}$ ) is 17% higher as compared to that measured at PSA ( $18.6\ W\ m^{-2}$ ). The latter value is more realistic, as it is the result of local measuring with a radiometer, during a six-year period (Malato et al. 2001b). However, to keep coherence of the whole data, the estimated value has been used in the analysis.

Table 6.32. Estimation of solar UV radiation available in several EU sites.

Location	Global solar radiation <sup>a</sup> ( $kWh\ m^{-2}\ day^{-1}$ )	$UV_G$ estimated <sup>b</sup> ( $W\ m^{-2}$ )
Las Palmas (Spain)	6.344	26
Almería (Spain)	5.238	22
Paris (France)	3.489	15
Kobenhavn (Denmark)	3.115	13
Kiruna (Sweden)	2.861	12

<sup>a</sup> At optimum angle. Source: EU 2005.

<sup>b</sup> Calculated Assuming 5% of global radiation.

## 6.6.4. Life Cycle Impact Assessment

The influence of UV radiation availability on solar-driven photo-Fenton can be seen in figure 6.21. The LCIA results are displayed in the graphic as weighted score, that is, after applying normalization and summing up each impact indicator score. This approach has been chosen to show the results since it allows to display them in a single graphic; otherwise a graphic should be displayed for each impact category. Except heterogeneous photocatalysis, the other alternatives, including the sensitivity analysis results on activated carbon, GAC (S.A.), are shown along with solar-driven photo-Fenton. For alternatives not based on solar energy, their impact score is constant and thus does not change as a function of  $UV_G$ . The numeric values on which figure 6.24 is based are shown in tables 6.A.20 and 6.A.21 in appendix 4.

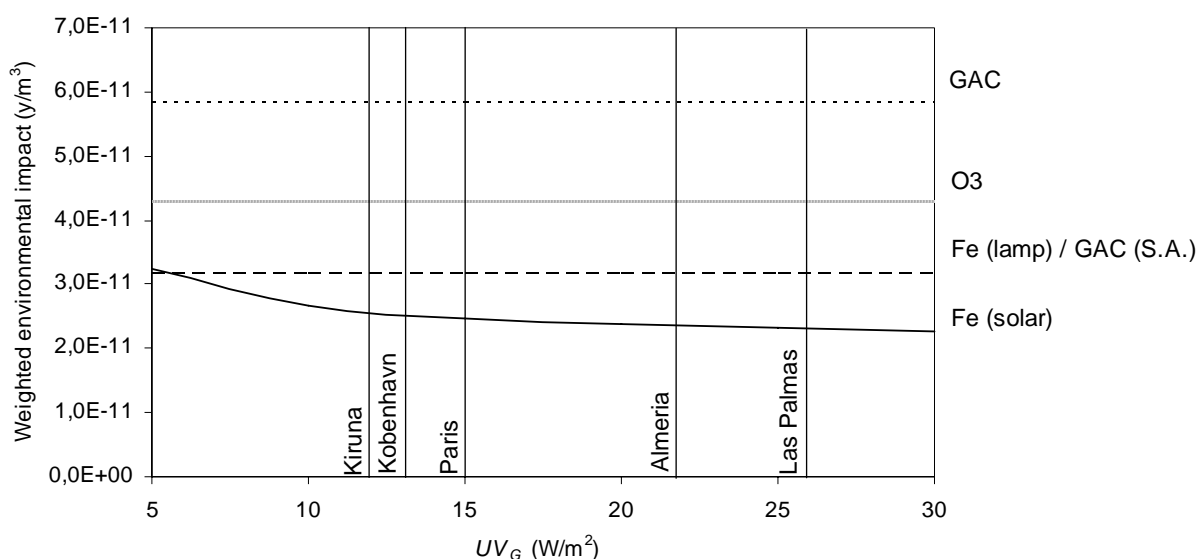

Figure 6.24. Weighted environmental impact of several alternatives as a function of UV radiation available.

Figure 6.24 shows that as  $UV_G$  decreases the environmental impact of solar-driven photo-Fenton slowly increases, being this effect specially remarkable for  $UV_G$  values equal or lower than  $10 \text{ W m}^{-2}$ . The breakeven point between solar-driven photo-Fenton, lamp-driven photo-Fenton and GAC (S.A.) is found at  $5\text{-}6 \text{ W m}^{-2}$ , while for the remaining technologies it is lower, located out of the range of  $UV_G$  values analysed.

It must be highlighted that all the locations chosen for the analysis, even Kiruna, appear to have enough UV radiation available to justify from an environmental point of view the application of solar-driven photo-Fenton. It has to be borne in mind, however, that the  $UV_G$  values used correspond to the yearly average, regardless of the seasonal variability. In a location like Kiruna, in the arctic circle, applying a solar AOP would imply stopping the plant at least during december, when the polar night takes place, and having less than 5 hours between sunrise and sunset during january and part of november. This should be overcome by applying an alternative treatment during this period.

Finally, it can be seen that for  $UV_G$  values higher than  $10 \text{ W m}^{-2}$ , the difference in overall impact is very narrow. Thus, for example, between Las Palmas and Kobenhavn there is a 50% reduction in terms of  $UV_G$ , but this implies only a 9% increase in weighted impact.

## 6.7. Assessment of Measures for Environmental Improvement

LCA allows to identify the processes that contribute most to the environmental impact of the system under study. This has been done in the contribution analysis of section 6.4. As a result of that analysis, strategies for environmental optimization can be defined, and the inventory and LCIA can be recalculated, allowing to assess the potential environmental improvements derived from the measures proposed. This type of assessment is carried out in this section, for solar photo-Fenton and ozonation, the technologies that have received more attention within the CADOX project. For each of these alternatives, the measures aimed at improving the system are described, and the inventory is recalculated for those parameters for which changes occur. Finally the LCIA results for the improved alternatives are put in contrast with the original LCIA results.

### 6.7.1. Solar-driven photo-Fenton

The main impacts associated to solar-driven photo-Fenton are related to hydrogen peroxide consumption and infrastructure. The former is not subject to changes here, as this parameter is considered to be optimized. On the other hand, infrastructure can be improved by decreasing the material intensity of the solar field.

#### 6.7.1.1. Measures to be taken

According to Ecosystem (Vincent 2005) the detailed measures that could be taken are the following:

- Installation of the CPCs on the roof of the industrial facility, laying parallel to the roof slope, or hanging on the facade.
- Installation a photovoltaic system for autonomous supply of electricity.

Installing the CPCs on the roof avoids the need for paving the ground. In addition, the fact that the CPCs lie down or are hanging allows to eliminate several structural elements needed to stand the CPC structures. Another important advantage is on land requirements, as the space that would be needed for the solar field on the ground is left free. A potential disadvantage, however, is that depending on the roof slope the total CPC aperture area may increase, as we move from 37°, the optimum in the case of Almería. Concerning energy consumption, a drawback is the need to pump the water from the ground level to the roof when a batch starts, although according to Ecosystem, this additional consumption can be neglected and has not been taken into account. On the other hand, installing photovoltaic panels can help to improve the environmental performance with regard to energy supply. These set of measures are only suggestions addressed to future applications of the CADOX technology, and have not been implemented in the demonstration plant.

#### 6.7.1.2. Inventory analysis

The following table summarizes the material savings related to a solar field installed on the roof. As can be seen, the materials related to terrain preparation (concrete and reinforcing steel) are avoided, while other materials decrease substantially. These weight reductions imply not only reducing basic material production but also finishing processes such as extrusion, anodising as well as less transport service to deliver the materials to the plant site.

Table 6.33. Weight savings per m<sup>2</sup> CPC installed on the roof, with regard to an equivalent installation on the ground.

Elements in solar field	Reduction*
Stainless steel elements	25%
Galvanized steel elements	67%
Anodised aluminium elements	29%
Concrete	100%
Reinforcing steel	100%
Concrete curb	100%

\* Calculated as  $[1 - (\text{weight on roof} / \text{weight on ground})] \times 100$   
 Source: Calculated from Ecosystem data.

The roof scenario for solar photo-Fenton has been assessed under three possibilities concerning the roof slope: 37° (optimum case), 0° (flat) and 90° (facade, facing south). According to Ecosystem (Vincent 2005), the total CPC aperture area would increase by 0%, 14% and 49% respectively, leading to  $S_{CPC}$  values of 100 m<sup>2</sup>, 114 m<sup>2</sup>, and 149 m<sup>2</sup>.

Concerning the installation of a photovoltaic system, this implies that plant operation will not be charged with the environmental burdens of the average european mix for electricity production. Nevertheless, the impact of photovoltaic infrastructure must be taken into account: panels, batteries, converter, electronic equipment, etc. With the exception of batteries, the Data for all these elements has been obtained from the Ecoinvent database (Jungbluth 2004a, 2004b, 2005). As this is a prospective assessment, the future technology for solar modules production has been chosen. The difference with the current technology is that higher energy efficiency is considered for silicon production.

The dataset used is *3kWp slanted-roof installation, pc-Si, future, on roof, CH*<sup>16</sup>. It includes all components for the installation of a 3kWp photovoltaic plant, energy use for the montage, transport of materials and persons to the construction place as well as disposal of components. As can be seen in appendix 2, where the calculations for dimensioning the photovoltaic system are done, the photocatalytic plant needs less than 3 kWp to be installed. This has been taken into account by computing in the inventory the proportional fraction of the dataset. Thus, for example, if the photovoltaic system needed is 1 kWp, then only 0.33 units of the mentioned dataset are computed. Table 6.35 shows the photovoltaic infrastructure (excluding batteries) associated to the functional unit

Production of batteries is not included in Ecoinvent, as photovoltaic energy is evaluated as connected to the grid, to export all the power produced. Our application however is for autonomous supply, hence the environmental burdens from storage devices must be included. The data for lead-acid batteries production has been obtained from literature, per kg of standard battery. Material composition has been obtained from Rydh (1999) and energy requirements as well as emissions of lead during manufacturing have been obtained from Rantik (1999). These data are displayed in table 6.34.

<sup>16</sup> The dataset refers to production of a 3 kW peak photovoltaic installation on a slanted roof in Switzerland (CH), being the panels of polycrystalline silicium, considering the future technology for panels production.

Table 6.34. Inventory per kg of standard lead-acid battery.

Concept	Materials and processes	Amount per kg battery	Ecoinvent datasets used and comments
Active material, grids and poles	Lead (kg)	0.61	0.61 kg <i>Lead, at regional storage, RER</i>
Electrolyte	Water (kg)	0.13	0.13 <i>Water, deionised, at plant, CH</i>
Electrolyte	Sulphuric acid (kg)	0.096	0.096 kg <i>Sulphuric acid, liquid, at plant RER</i>
Cases and covers	Polypropylene (kg)	0.082	0.082 kg <i>Polypropylene, granulate, at plant, RER</i>
Separators	Polyethylene (kg)	0.02	0.02 kg <i>Polyethylene, HDPE, granulate, at plant, RER</i>
Tubular mats	Polyester (kg)	0.003	0.003 kg <i>Polyester resin, unsaturated, at plant, RER</i>
Connectors	Copper (kg)	0.003	0.003 kg <i>Copper, at regional storage, RER</i>
Energy used in the factory	Electricity (kWh)	1.33	1.33 kWh <i>Electricity, medium voltage, production UCTE, at grid</i>
Energy used in the factory	Oil (MJ)	0.102	0.102 MJ <i>Heavy fuel oil, at industrial furnace 1 MW, RER</i>
Energy used in the factory	LPG (MJ)	0.137	0.137 MJ <i>Natural gas, burned in industrial furnace &gt;100kW, RER (combustion of LPG is not included in Ecoinvent, natural gas used as approximation)</i>
Emission to air from factory	Lead (kg)	1.242E-06	
Emission to water from factory	Lead (kg)	4.808E-06	

Source: Rydh 1999; Rantik 1999.

As the inventory data for batteries is expressed per kg, the number and unitary weight of the batteries employed has to be defined. This has been done in appendix 2, where 750 Ah Fulmen batteries are chosen. These have an unitary weight of 37 kg. The number of units needed depends on the roof case considered. Table 6.35 summarizes the weight of batteries associated to the functional unit for each case.

Table 6.35. Photovoltaic system in the photocatalytic plant for different roof slopes per functional unit.

Photovoltaic system data	Fe (solar) 0°	Fe (solar) 37°	Fe (solar) 90°
Data per plant			
- Installed power (kWp) <sup>a</sup>	1.672	1.520	2.128
- Number of 750 Ah batteries needed <sup>a</sup>	5	4	6
Data per functional unit			
- Fraction of a 3kWp installation (per m <sup>3</sup> wastewater) <sup>b</sup>	1.5E-05	1.4E-05	1.9E-05
- Batteries per m <sup>3</sup> wastewater (kg) <sup>b</sup>	4.9E-03	4.0E-03	5.9E-03

<sup>a</sup> See appendix 2.

<sup>b</sup> The plant treats 2,500 m<sup>3</sup> year<sup>-1</sup> during 15 years.

## 6.7.2. Ozonation

The most critical issues in the alternative applying ozonation are oxygen and electricity consumption, that is, the main inputs for ozone production. Here a strategy is presented and assessed to optimize these parameters.

### 6.7.2.1. Measures to be taken

The amount of power and oxygen consumed by the ozoniser can not be changed as long as the equipment is not redesigned to improve its specific efficiency. What can be improved, on the other hand, is the ozone transfer efficiency.



As has been shown in the inventory analysis, the average figure in the pilot plant experiments is 50%, being the remaining 50% lost. According to Trailigaz, the demonstration plant can be designed to increase this value, by injecting ozone in two contact columns in series (Perrot 2005):

- In the first contact column, ozone is fed from the ozoniser by a hydroinjector. In order to improve the contact between effluent and ozone gas, a recirculation pump is installed which sucks from a second hydroinjector the ozone off gas leaving the second ozone contact column. The ozone contained in the off-gas leaving the first contact column is destroyed by a thermo-catalytic ozone destructor.
- In the second contact column, ozone is fed from the ozoniser by conventional porous diffusers.

In such a way, the ozone loss is minimized, achieving an overall transfer efficiency of 75%. This strategy has been applied by Trailigaz in the design of the ozone system to be used in the demonstration plant. Figure 6.22 shows some details of this ozone unit.



Figure 6.25. Images of the ozone unit designed by Trailigaz for the CADOX demonstration plant.

#### 6.7.2.2. Inventory analysis

The operation of the above described system has several implications from the inventory perspective:

- On the one hand, less ozone has to be produced per functional unit, implying less energy consumed in the ozoniser, pump, as well as less cooling water, oxygen and transport of oxygen to the plant.
- On the other hand, these advantages come at the price of increasing the installed power, by adding a new pump for recirculation of ozone. The pump in the demonstration plant uses 2.2 kWh kg<sup>-1</sup> ozone produced.

As a consequence, the potential benefits of increased ozone transfer have to be balanced to the increase in power installed. In table 6.36 the consumption of electricity for all purposes as well as that of ancillary materials has been recalculated, taking into account the new power-consuming device along with the increased ozone transfer efficiency of 75%. These calculations have been carried out in the same way as in the baseline inventory analysis (section 6.3).

Table 6.36. Inventory of electricity and ancillary materials per functional unit for ozonation with increased ozone transfer efficiency.

Process	O3 75%
Electricity consumption	
- Ozonisorator	12.8
- Main pump	1.65
- Recirculation pump	2.35
- Total (kWh)	16.8
Oxygen (kg)	8.9
Cooling water (litres)	2,130
Transport by train (kg ·km)	981
Transport by truck (kg ·km)	459

### 6.7.3. Summary table

Table 6.37 summarizes the inventory analysis of the improved AOP treatments, incorporating the calculations made in sections 6.7.1 and 6.7.2. This table is an equivalent for table 6.26: it shows the Ecoinvent datasets used as well as emissions not included in the datasets, also using the Ecoinvent nomenclature. The inventory corresponding to further treatment of the advanced oxidation effluent in the MWWTP is not shown here, as there are no changes in this process for the respective treatments.

Table 6.37. Disaggregated inventory table for improved AOPs, per functional unit, excluding MWWTP.

Processes	Fe (solar) 0°	Fe (solar) 37°	Fe (solar) 90°	O3 75%
<b>CPC infrastructure:</b>				
<i>Chromium steel 18/8, at plant, RER (kg)</i>	0.018	0.016	0.023	
<i>Steel, low-alloyed, at plant, RER (kg)</i>	1.7E-04	1.5E-04	2.2E-04	
<i>Zinc coating, pieces, RER (m<sup>2</sup>)</i>	1.0E-05	8.9E-06	1.3E-05	
<i>Aluminium, production mix, at plant, RER (kg)</i>	0.021	0.018	0.028	
<i>Section bar extrusion, aluminium, RER (kg)</i>	0.021	0.018	0.028	
<i>Anodising, aluminium sheet, RER (m<sup>2</sup>)</i>	0.014	0.013	0.019	
<i>Glass tube, borosilicate, at plant, DE (kg)</i>	0.020	0.018	0.027	
<i>Polypropylene, granulate, at plant, RER (kg)</i>	4.3E-03	3.7E-03	5.6E-03	
<i>Extrusion, plastic pipes, RER (kg)</i>	6.1E-05	5.3E-05	8.0E-05	
<i>Injection moulding, RER (kg)</i>	3.7E-03	3.2E-03	4.8E-03	
<i>Concrete, normal, at plant, CH (m<sup>3</sup>)</i>				
<i>Reinforcing steel, at plant, RER (kg)</i>				
<i>Autoclaved aerated concrete block, at plant, CH (m<sup>3</sup>)</i>				
<i>Transport, freight, rail, RER (kg · km)</i>	21	18	27	
<i>Transport, lorry 32t, RER (kg · km)</i>	6	6	8	
<i>3kWp slanted-roof installation, pc-Si, future, on roof, CH (units)</i>	1.5E-05	1.4E-05	1.9E-05	
<b>Lead-acid batteries:</b>				
<i>Lead, at regional storage, RER (kg)</i>	3.0E-03	2.4E-03	3.6E-03	
<i>Water, deionised, at plant, CH (kg)</i>	6.4E-04	5.1E-04	7.7E-04	
<i>Sulphuric acid, liquid, at plant RER</i>	4.7E-04	3.8E-04	5.7E-04	
<i>Polypropylene, granulate, at plant, RER</i>	4.0E-04	3.2E-04	4.9E-04	
<i>Polyethylene, HDPE, granulate, at plant, RER (kg)</i>	9.9E-05	7.9E-05	1.2E-04	
<i>Polyester resin, unsaturated, at plant, RER (kg)</i>	1.5E-05	1.2E-05	1.8E-05	
<i>Copper, at regional storage, RER (kg)</i>	1.5E-05	1.2E-05	1.8E-05	
<i>Electricity, medium voltage, production UCTE, at grid (kWh)</i>	6.6E-03	5.2E-03	7.9E-03	
<i>Heavy fuel oil, at industrial furnace 1 MW, RER (MJ)</i>	5.0E-04	4.0E-04	6.0E-04	
<i>Natural gas, burned in industrial furnace &gt;100kW, RER (MJ)</i>	6.8E-04	5.4E-04	8.1E-04	
<i>Electricity, medium voltage, production UCTE, at grid (kWh)</i>				16.8
<i>Oxygen, liquid, at plant, RER (kg)</i>				8.9
<i>Hydrogen peroxide, 50% in H<sub>2</sub>O, at plant, RER (kg)</i>	1.7	1.7	1.7	
<i>Iron sulphate, at plant, RER (kg)</i>	0.1	0.1	0.1	
<i>Titanium dioxide, production mix, at plant, RER (kg)</i>				
<i>Sulphuric acid, liquid, at plant, RER (kg)</i>	0.13	0.13	0.13	
<i>Sodium hydroxide, 50% in H<sub>2</sub>O, production mix, at plant, RER (kg)</i>	0.08	0.08	0.08	0.08
<i>Tap water, at user, RER(kg)</i>	2.50	2.19	3.27	2133
<i>Transport, freight, rail, RER (kg · km)</i>	4012	4012	4012	981
<i>Transport, lorry 32t, RER (kg · km)</i>	669	669	669	459
<b>Spent catalyst management:</b>				
<i>Transport, lorry 16t, RER (kg · km)</i>	38	38	38	
<i>Residual material landfill facility, CH (units)</i>	1.6E-09	1.6E-09	1.6E-09	
<i>Process-specific burdens, residual material landfill, CH (kg)</i>	0.76	0.76	0.76	
<i>Cement unspecified, at plant, CH (kg)</i>	0.31	0.31	0.31	
<i>Disposal, cement, hydrated, 0% water, to residual material landfill, CH (kg)</i>	0.76	0.76	0.76	
<i>Transport, freight, rail, RER (kg · km)</i>	0.031	0.031	0.031	
<i>Transport, lorry 28t, CH</i>	0.015	0.015	0.015	

Table 6.37. Cont.

Emissions	Fe (solar) 0°	Fe (solar) 37°	Fe (solar) 90°	O3
To air, high population density				
DOC degradation by AOPs:				
<i>Carbon dioxide, fossil (kg)</i>	0.77	0.77	0.77	0.66
Lead-acid batteries manufacturing:				
<i>Lead (kg)</i>	6.1E-06	4.9E-06	7.3E-06	
To water, river				
Spent catalyst management:				
<i>Titanium, ion (kg)</i>				
<i>Iron, ion (kg)</i>	1.7E-07	1.7E-07	1.7E-07	
Lead-acid batteries manufacturing:				
<i>Lead (kg)</i>	2.4E-05	1.9E-05	2.9E-05	
To groundwater, long-term				
Spent catalyst management:				
<i>Titanium, ion (kg)</i>				
<i>Iron, ion (kg)</i>	9.9E-05			
Land use	Fe (solar) 0°	Fe (solar) 37°	Fe (solar) 90°	O3
<i>Occupation, industrial site (m<sup>2</sup>·year)</i>	0.03	0.03	0.03	0.03

#### 6.7.4. Life Cycle Impact Assessment results

After analyzing the material and energy implications of the measures for improvement, their potential environmental consequences are presented by means of the LCIA results, comparing the improved alternative with the original.

##### 6.7.4.1. Solar-driven photo-Fenton

Figure 6.26 shows the characterisation results for baseline and improved solar-driven photo-Fenton. The numeric values on which this figure is based are shown in tables 6.A.16 to 6.A.18. As can be seen in the figure, the installation of CPCs on roof or facade together with a photovoltaic system implies in general terms a decrease in environmental impact, regardless of the slope. However, the best performance is found when the roof slope approaches the optimum of 37°, although the differences between the three improved options are very small. The overall impact reduction is in the range of 10-15%, except for eutrophication (EP) which is insensitive to these changes. The greatest impact reduction (50%) is found in land use (LU), due to the fact that the ground previously used to install the solar field is now free, whereas the space used on the roof or facade is not allocated to wastewater treatment, but to the industrial facility.

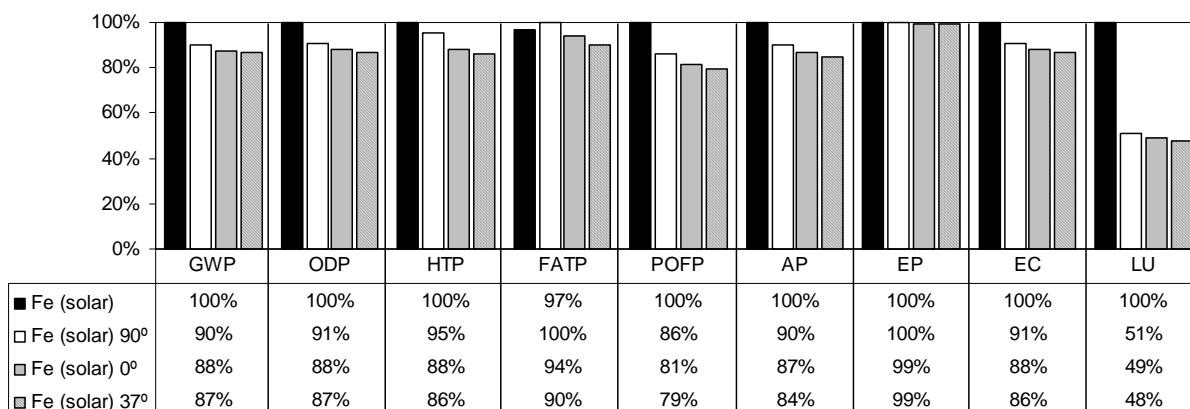

Figure 6.26. Characterisation results for baseline and improved solar driven photo-Fenton, relative to the most impacting alternative per indicator.

Although this cannot be observed from the graphic, it has to be highlighted that from the measures taken to improve the system, that which contribute most to decrease the environmental impact is the installation of the CPCs on the roof or the facade. The photovoltaic system contributes less for two reasons: first, electricity consumption is not a critical issue in solar-driven photo-Fenton, therefore the margin for improvement is narrow. Second, production of photovoltaic cells is an energy-intensive process, and this energy is nowadays mainly obtained from fossil sources. As a consequence, the environmental profile of photovoltaic energy is not as favorable as should be expected; this is a typical case of an emergent technology deeply affected by its background system (Sandén et al. 2005).

#### 6.7.4.2. Ozonation

Ozonation is compared with its improved version as well as with its closer competitors in environmental terms, lamp-driven photo-Fenton and GAC(S.A), in order to ascertain whether or not improved ozonation obtains better results. The characterisation results are shown in figure 6.27, while the numeric values on which this figure is based can be found in appendix 4.

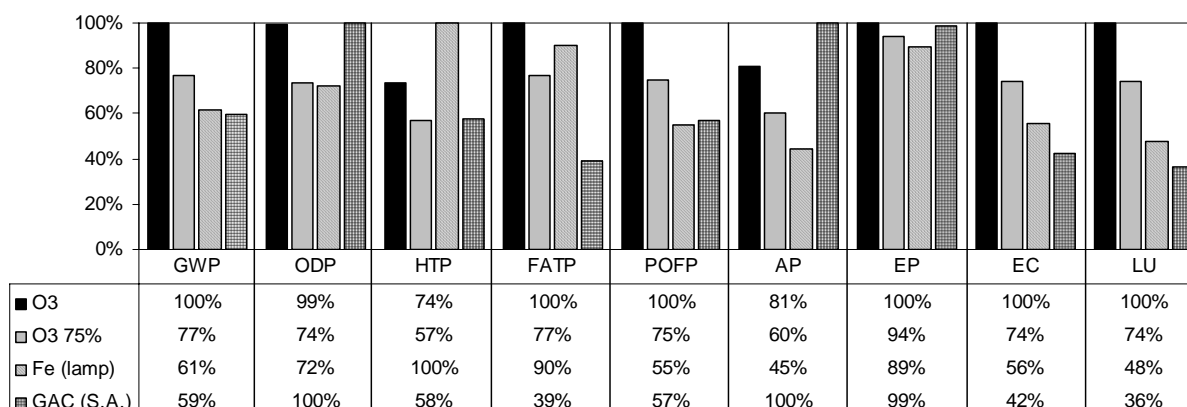

Figure 6.27. Characterisation results for baseline and improved ozonation and lamp-driven photo-Fenton, relative to the most impacting alternative per indicator.

It can be seen in the figure that improving ozone transfer is a good strategy to decrease the environmental impact of ozonation. Increasing transfer efficiency by a factor of 1.5 involves a decrease of about 25% in all indicators. These results evidence that improving ozone transfer is worth installing a powerful recirculation pump. With regard to GAC (S.A.) and lamp-driven photo-Fenton, it can be seen that the differences are reduced substantially but the ranking in every impact category remains unchanged. Nevertheless, if it is taken into account that the assessment of lamp-driven photo-Fenton is of lower quality, due to the lack of experimental data, its better performance with regard to improved ozonation is called into question.

## 6.8. Cost Assessment

This section presents the methodology and results of the LCC carried out for all the alternatives under study. The main objective of this assessment is to determine the cost in € m<sup>-3</sup> Femac wastewater for each alternative, as well as the relative importance of the different cost components. Also the sensitivity of cost to the parameters subject to changes in sections 6.6 and 6.7 is evaluated.

### 6.8.1. Costing methodology

The present cost assessment intends to include internal costs only. Therefore externalities such as social or environmental costs are excluded from the analysis, as long as they are not included in the market price of the goods and services computed. However, quantification of the environmental externalities related to the alternatives under study is precisely the subject of the LCA. As a consequence, the environmental and economic assessments are complementary in this study.

In order to match the economic calculations with the LCA, the former is based on the same data used throughout the latter, namely time frame, wastewater to treat, plant capacity, material and energy balances, etc. A special remark has to be made with regard to infrastructure-related costs: in the LCA, production of infrastructure has only been taken into account for solar-driven AOPs, while infrastructure dismantling has been excluded for all alternatives. The criteria for this decisions are the relative environmental relevance of the processes. However, in an economic analysis the criteria is not environmental relevance but economic. Thus, costs related to infrastructure, that is, investment or capital costs, can not be excluded from the analysis, as usually they contribute significantly to the overall cost of a project. In our analysis, only the initial investment is taken into account, while plant decommissioning is excluded, as it has been found to be negligible for the most infrastructure-intensive alternatives, the solar-driven AOPs (this is justified in appendix 3).

Another cost excluded from the calculation is that associated with treatment in the MWWTP of the effluent obtained after the advanced oxidation step. The sewage treatment fee usually depends on effluent parameters (Catalan Water Agency 2005) that have not been monitored, such as inhibitory substances, conductivity, or others like suspended solids, that does not apply in our case, as we deal with a synthetic wastewater which contains no particles.

The base date for this cost assessment is 2005 and the prices are expressed in constant € for that year. According to Fuller and Petersen (1996), it is easier to conduct the economic analysis in constant currency, because the inflation rate from year to year during the study period need not be estimated. The constant price approach, however, implies using a real interest rate, that is, an interest rate that excludes the rate of inflation. On the other hand, VAT has been excluded from the calculations.

The overall cost of an alternative is split in two basic components: an operational cost and an investment cost, as shown in equation 6.8:

$$TC = \frac{IC \cdot CRF}{V} + OC \quad (6.8)$$

Where:

$TC$  is the total unitary cost of wastewater treatment (€ m<sup>-3</sup>),

$IC$  is the total investment cost of the wastewater treatment plant (€),  
 $OC$  is the yearly operating cost of the wastewater treatment plant (€ m<sup>-3</sup>), and  
 $CRF$  is the capital recovery factor (year<sup>-1</sup>), which is calculated as follows (EEA 1999):

$$CRF = \left( \frac{r \cdot (1+r)^N}{(1+r)^N - 1} \right) \quad (6.9)$$

Where:

$r$  is the interest (or discount) rate (%), and

$N$  is the study period (15 years).

The cost of capital is different for each investor, so interest rates will differ depending on who is making the investment or providing the finance, as well as on the risk involved in the project (EIPPCB 2005). The choice of this parameter can greatly influence the results of the economic analysis, since high interest rates promote projects with low capital costs, and viceversa. Typical values used in industrial wastewater treatment range from 6% (Sattler et al. 2004) to 10% (Hirvonen et al. 1998; Zanitsch and Stenzel 1978). In the present study a real interest rate of 6% is chosen as a baseline figure, leading to a  $CRF$  of 10.3%. This is the fraction of the investment that must be paid every year during the study period.

## 6.8.2. Calculation of investment costs

Investment costs for all alternatives include:

- Plant equipment,
- Spare parts,
- Transport and installation,
- Engineering and set-up,
- Unforeseen costs.

It is assumed that normal services such as water and power are available on-site, and that land is available at no cost. In the following sections the way in which the cost has been calculated and the source of the data are detailed.

### 6.8.2.1. Solar driven AOPs

The investment cost ( $IC$ ) of a solar photocatalytic detoxification plant has been calculated from the cost of the Albaida plant, obtaining a general expression as a function of the CPC aperture area:

$$IC = C_{CPC} \cdot S_{CPC} + 25 \cdot (2.76 \cdot S_{CPC} + 70) + 27,000 \quad (6.10)$$

Where:



$C_{CPC}$  is the unitary cost of the plant per unit CPC aperture area (€/m<sup>2</sup>), excluding control equipment and terrain preparation. The figure for photo-Fenton has been obtained directly from the cost of the Albaida plant, While for heterogeneous photocatalysis a lower figure has been used, as it is assumed that for high CPC surfaces there are economies of scale (Blanco 2002).

$S_{CPC}$  is the total CPC aperture area of the plant (m<sup>2</sup>),

25 is the unitary cost of a reinforced-steel concrete platform (€ m<sup>-2</sup>). This data has been obtained from a building company (Bala 2005),

$(2.76 \cdot S_{CPC} + 70)$  is an expression to calculate total plant area, similarly as in equation 6.7, and

27,000 is the total cost of control equipment for a photocatalytic detoxification plant (€).

The following table shows the calculation of  $IC$  for both photo-Fenton and heterogeneous photocatalysis. As can be seen, the higher area needed by the latter implies a considerably higher investment cost.

Table 6.38. Calculation of investment cost of solar driven photo-Fenton and heterogeneous photocatalysis plants.

Parameter	Fe (solar)	Ti (solar)
$S_{CPC}$ (m <sup>2</sup> )	100	2,150
$C_{CPC}$ (€/m <sup>2</sup> )	950	500
$IC$ (€)	131,000	1,252,000

#### 6.8.2.2. Ozonation

The investment cost of the ozonation plant has been obtained from two sources. Trailigaz has provided the total cost for an unit as that designed for the CADOX demonstration plant, but producing only 0.4 kg Ozone per hour, the capacity needed in our application. The cost is 100,000 €, excluding installation and set-up which have been estimated by Ecosystem (Vincent 2005) to be 12,000 €, leading then to an overall  $IC$  of 112,000 €.

#### 6.8.2.3. Lamp-driven photo-Fenton

The investment cost of a photo-Fenton plant using artificial light has been estimated by Ecosystem (Vincent 2005) as follows:

- 7,000 € for control equipment,
- 12,000 € for the lamp system excluding lamps,
- 6,000 € for other costs

The overall  $IC$  is then 25,000 €.

#### 6.8.2.4. Activated carbon adsorption

The investment cost of a plant applying GAC filtering has been estimated by extrapolation from a tertiary treatment unit installed at MASA Decor (Dominguez 2005). As the total filter volume required in our application is higher than that in MASA Decor, the following expression, derived from Peters and Timmerhaus (1991) has been used:

$$COST_B = COST_A \cdot \left( \frac{SIZE_B}{SIZE_A} \right)^{0.6} \quad (6.11)$$

Where:

$COST_B$  is the total cost of the GAC plant investigated, excluding the carbon inventory (€),

$COST_A$  is the total cost of the GAC plant installed at MASA Decor (30,000 €), excluding the carbon inventory,

$SIZE_B$  is the overall filter volume to be installed for the plant under study (4.11 m<sup>3</sup>), as shown in section 6.3.3.1,

$SIZE_A$  is the overall filter volume of the GAC plant installed at MASA Decor (1 m<sup>3</sup>), and

0.6 is the scale factor.

From equation 6.11 the total cost of the plant is 70,000 €, to which the cost of the carbon inventory has to be added. The adsorbers considered have a unitary volume of 4.11 m<sup>3</sup> (TIGG 2005); as two units are installed in series, a total volume of 8.22 m<sup>3</sup> is obtained, of which only 63% is effectively occupied by the carbon bed. The density of Jacobi Aquasorb 5000 is 230 kg m<sup>-3</sup> and its unitary cost (Domínguez 2005) 3 € kg<sup>-1</sup>. Therefore, the cost of the initial carbon inventory is 3,600 € and the overall IC 73,600 €.

### 6.8.3. Calculation of operation costs

Operation costs include the following items:

- Chemical supplies (hydrogen peroxide, ferrous sulfate, titanium dioxide, oxygen, sulphuric acid, and sodium hydroxide),
- Electricity,
- Water,
- Replacement of lamps,
- Spent catalyst management (transport, inertization and landfilling),
- Spent GAC regeneration,
- Personnel, and
- Maintenance.

The unitary costs for all these items have been obtained from several sources as can be seen in table 6.39. The cost of material supplies as well as GAC regeneration include also the transport service. On the other hand, spent catalyst management has been computed as the sum of three operations: transport, inertization and landfilling.

Table 6.39. List of unitary costs used to calculate operation costs.

Concept	Cost	Source
Oxygen	0.12 € kg <sup>-1</sup>	Trailigaz (Perrot 2004)
Hydrogen peroxide 30%	0.5262 € kg <sup>-1</sup>	Albaida, Recursos Naturales y Medioambiente
Ferrous sulphate	0.2531 € kg <sup>-1</sup>	Albaida, Recursos Naturales y Medioambiente
Sulphuric acid	0.2141 € kg <sup>-1</sup>	Albaida, Recursos Naturales y Medioambiente
Sodium hydroxide 50%	0.248 € kg <sup>-1</sup>	Albaida, Recursos Naturales y Medioambiente
Titanium dioxide	19.34 € kg <sup>-1</sup>	Quimidroga
Power	0.07 € kWh <sup>-1</sup>	Assumption
Water	0.767 € m <sup>-3</sup>	DSM Deretil
Lamp replacement	21 € unit <sup>-1</sup>	Alealuz
Transport	0.02 € kg <sup>-1</sup>	Ecosystem (Vincent 2005)
Inertization	0.15 € kg <sup>-1</sup>	Ecosystem (Vincent 2005)
Landfill	0.0704 € kg <sup>-1</sup>	Jenseit et al. 2003
Carbon regeneration	1.8 € kg <sup>-1</sup>	Aguas de Levante (Cortés-Russell 2005)
Personnel	20,000 € man year <sup>-1</sup>	Blanco (2002)

Calculation of the operation costs is done by applying the prices detailed in table 6.39 to the material and energy balance carried in the inventory analysis. Costs not related to material and energy balances are personnel and maintenance. The latter are calculated as 2% of the initial investment (Blanco 2002; Hirvonen et al. 1998). With regard to personnel costs, they are calculated for the solar-driven plants with the following assumptions:

- 2 hours day<sup>-1</sup> for general tasks such as filling and emptying of batches, and laboratory control,
- 2 hours week<sup>-1</sup> for maintenance tasks, and
- 5 days year<sup>-1</sup> for unforeseen tasks such as incidences.

This makes an overall 874 hours year<sup>-1</sup>. Considering 1,750 hours man<sup>-1</sup> year<sup>-1</sup>, the personnel requirements are 0.5 man-year. Although the specific tasks vary between alternatives (for example filling of batches does not apply in plants running in continuous mode), this figure has been considered valid as an approximation for the other alternatives, including GAC adsorption. Table 6.40 shows the calculation of the operation costs per m<sup>3</sup> wastewater, including all the items discussed above.

Table 6.408. Operation costs for all alternatives.

Operation costs	Fe (solar)	Ti (solar)	O3	Fe (lamp)	GAC
Chemicals					
Oxygen			1.59		
Hydrogen peroxide 30%	3.31			3.31	
Ferrous sulphate	0.03			0.03	
Titanium dioxide		0.39			
Sulphuric acid	0.03			0.03	
Sodium hydroxide	0.04		0.04	0.04	
Power	0.05	1.27	1.52	1.01	0.01
Water	0.00	0.04	2.45		
Lamp replacement				2.21	
Waste management					
Transport	0.02	0.01		0.02	
Inertization	0.11	0.06		0.11	
Landfill	0.11	0.06		0.11	
GAC regeneration					7.40
Personnel	4.00	4.00	4.00	4.00	4.00
Maintenance	1.05	10.00	0.90	0.20	0.59
<b>Total (€ m<sup>-3</sup>)</b>	<b>8.74</b>	<b>15.82</b>	<b>10.50</b>	<b>11.06</b>	<b>12.00</b>

#### 6.8.4. Results of the cost assessment

Figure 6.28 shows the total cost in € m<sup>-3</sup> wastewater treated for each of the five alternatives under study, splitting it in the operation and investment components.

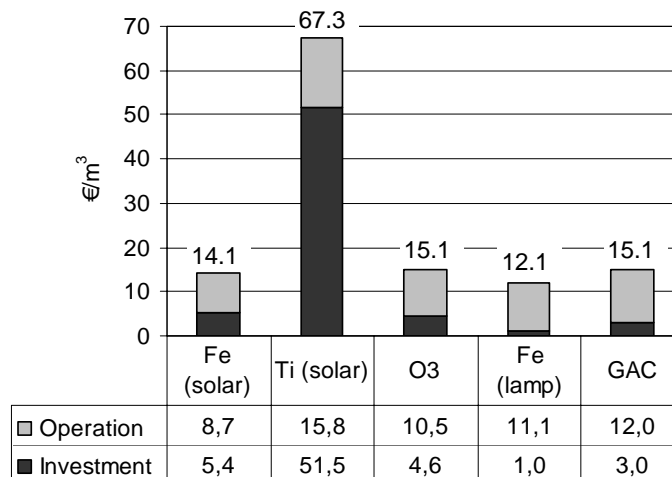

Figure 6.28. Results of the cost assessment for all alternatives.

From the results depicted in the figure, it is highlighted above all the difference in cost of heterogeneous photocatalysis with regard to the remaining alternatives. This is mainly caused by the high capital cost of the plant. Operation cost is dominated by maintenance, which in turn is also related to capital cost. We see then that this option is the less economically feasible for Femac treatment.

On the other hand, the cost of the remaining options is similar. The cheapest alternative is lamp-driven photo-Fenton, due to its low capital cost, followed by solar photo-Fenton, while the differences between GAC and ozonation are not considered to be significant. Therefore, with the exception of heterogeneous photocatalysis, the AOPs under study are quite competitive with regard to the reference technology, GAC adsorption.

Table 6.41 shows the results of a sensitivity analysis on the CRF. A value of 13.4% has been used, in accordance with USEPA's analysis of conventional water treatment systems (Link and Turchi 1991). It can be seen that increasing CRF up to 13.4% leads to an absolute cost increase from 3% in lamp-driven photo-Fenton to 23% in heterogeneous photocatalysis, but the relative ranking of alternatives remains unaltered.

Table 6.41. Sensitivity analysis of overall cost (€ m<sup>-3</sup>) with regard to CRF.

CRF (%)	Fe (solar)	Ti (solar)	O3	Fe (lamp)	GAC
10.3	14.1	67.3	15.1	12.1	15.1
13.4	15.8	82.8	16.5	12.4	16.0

### 6.8.5. Cost of solar photocatalysis as a function of UV light available

In section 6.6 a sensitivity analysis has been performed in order to investigate the effect of solar UV radiation availability on the environmental impact of solar-driven photo-Fenton. This section is intended also to answer that question, but from the economic point of view, namely how does the cost of the solar AOP increase or decrease when  $UV_G$  changes.

As discussed in section 6.6, decreasing  $UV_G$  implies a higher CPC aperture area if the same wastewater flow is to be treated. This in turn implies higher capital costs. In addition, as CPC area increases, the cost of pumping as well as maintenance cost also increases. The cost of water consumed for CPC cleaning also increases with CPC area, although this is expected to have a minor influence on total cost. All these items are recalculated by the same procedures explained in the baseline cost assessment, using the range of  $UV_G$  values of 5 to 30 W m<sup>-2</sup>, as has been done in the environmental assessment.

Table 6.42 shows the result of calculating the investment cost (*IC*), operation cost (*OC*) and total cost (*TC*) for the range of radiation intensities proposed, while figure 6.29 depicts the results graphically along with the costs for the other alternatives, except heterogeneous photocatalysis. The reference sites assessed in section 6.6 (Kiruna, Kobenhavn, Paris, Almeria and Las Palmas) are included in the figure as well.

Table 6.42. Calculation of costs in a solar-driven photo-Fenton plant for different  $UV_G$  values.

Costs	$UV_G$ ( $W\ m^{-2}$ )					
	5	10	15	20	25	30
IC (€)	408,500	218,600	155,300	123,700	105,000	92,000
OC ( $€\ m^{-3}$ )						
Hydrogen peroxide 30%	3.31	3.31	3.31	3.31	3.31	3.31
Ferrous sulphate	0.03	0.03	0.03	0.03	0.03	0.03
Sulphuric acid	0.03	0.03	0.03	0.03	0.03	0.03
Sodium hydroxide	0.04	0.04	0.04	0.04	0.04	0.04
Power	0.17	0.09	0.06	0.05	0.04	0.03
Water	0.006	0.003	0.002	0.002	0.001	0.001
Waste management						
Transport	0.02	0.02	0.02	0.02	0.02	0.02
Inertization	0.11	0.11	0.11	0.11	0.11	0.11
Landfill	0.11	0.11	0.11	0.11	0.11	0.11
Personnel	4.00	4.00	4.00	4.00	4.00	4.00
Maintenance	3.27	1.75	1.24	0.99	0.84	0.74
Total OC	11.09	9.48	8.95	8.68	8.52	8.41
TC ( $€\ m^{-3}$ )	27.9	18.5	15.3	13.8	12.8	12.2

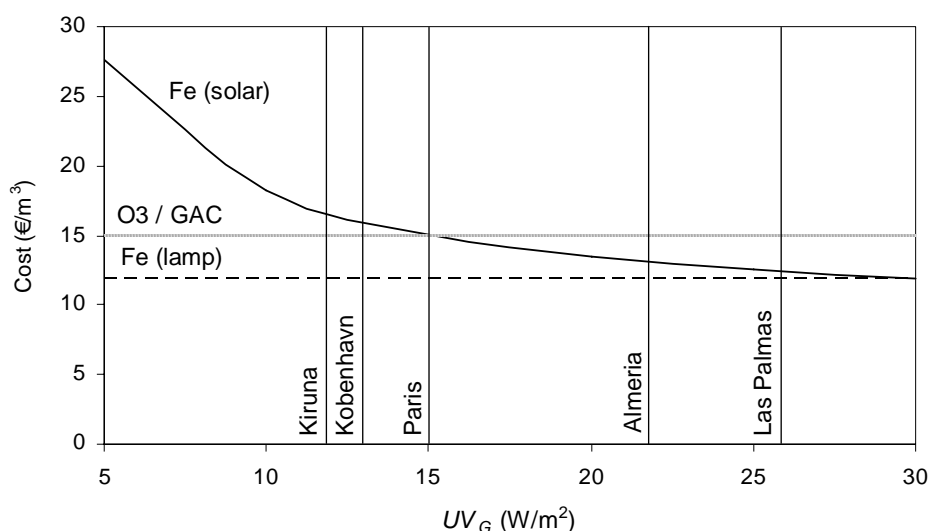

Figure 6.29. Cost of several alternatives as a function of UV radiation available.

Figure 6.29 shows clearly how the cost of solar-driven photo-Fenton increases rapidly as less UV radiation is available. From table 6.429 it can be seen that the main cause of this trend is due to increasing capital costs and maintenance costs. On the other hand, the cost of GAC, Ozonation as well as that of lamp-driven photo-Fenton is independent of  $UV_G$ , thus appearing as a flat line on the graph.

Two breakeven values can be identified in the figure. The first one occurs for a UV intensity of  $15\ W\ m^{-2}$ . In locations having at least this  $UV_G$  value, like Paris, Almeria or Las Palmas, solar-driven photo-Fenton is economically preferred to ozonation and GAC adsorption. As a consequence, in locations in northern Europe like Kobenhavn and Kiruna, with lower UV light available, ozonation and GAC adsorption would be more economically attractive than the solar AOP. The second breakeven value is found at  $30\ W\ m^{-2}$ ; at this point, solar-driven photo-Fenton becomes cheaper than the lamp-driven alternative. Nonetheless, nowhere in Europe such a  $UV_G$  value can be found.

## 6.8.6. Influence of measures for environmental improvement on costs

In section 6.7 several measures aimed at improving solar photo-Fenton and ozonation from an environmental point of view have been assessed. In this section those measures are retaken in order to check their influence not in environmental terms, but on overall cost.

### 6.8.6.1. Solar driven photo-Fenton

Installation of the solar field on the roof or facade in combination with photovoltaic energy implies several changes in investment cost. On the one hand, the cost of paving (25 € m<sup>-2</sup> plant) is avoided, and several structural elements in aluminium and stainless steel can also be removed, saving 24 and 29 € m<sup>-2</sup> CPC respectively (Vincent 2005). On the other hand, installation cost increases, as elevated work is more expensive. According to Ecosystem (Vincent 2005), this cost would increase by 10% with regard to a plant laying on the ground. The additional cost would be about 22 € m<sup>-2</sup> CPC. Finally, the additional cost of the photovoltaic system has to be added as a new component of the investment. Then, *IC* is calculated using equation 6.12:

$$IC = C_{CPC} \cdot S_{CPC} + 27,000 + PV \quad (6.12)$$

Where:

$C_{CPC}$  is the unitary cost of the plant per unit CPC area (€/m<sup>2</sup>), excluding control equipment. From the data presented above, for a plant installed on a roof or facade this parameter is: 950 - 24 - 29 + 22 = 919 €/m<sup>2</sup>.

$S_{CPC}$  is the total CPC aperture area of the plant (m<sup>2</sup>),

27,000 is the total cost of control equipment for a photocatalytic detoxification plant (€) and,

$PV$  is the total cost of the photovoltaic system (€).

Concerning operation costs, two components change with regard to a plant having the CPCs on the ground: one of them is maintenance, as this depends on the initial investment. The second is (grid) power consumption, which is zero due to the autonomous photovoltaic system. The remaining items (chemical supplies, personnel, etc.) are kept constant. Table 6.43 and 6.44 shows the total investment and operation costs, while in figure 6.30 the overall cost of the three roof options are compared to that of photo-Fenton on the ground.

Table 6.43. Calculation of investment cost for improved solar-driven photo-Fenton, for different roof slopes.

Parameter	Fe (solar) 0°	Fe (solar) 37°	Fe (solar) 90°
$PV$ (€) <sup>a</sup>	18,205	16,560	22,610
$S_{CPC}$ (m <sup>2</sup> ) <sup>b</sup>	114	100	149
$IC$ (€)	150,205	135,560	186,610

<sup>a</sup> See appendix 2.

<sup>b</sup> See section 6.7.1.2.

Table 6.44. Operation costs for improved solar-driven photo-Fenton, for different roof slopes.

Operation costs	Fe (solar) 0°	Fe (solar) 37°	Fe (solar) 90°
Chemicals			
Hydrogen peroxide 30%	3.31	3.31	3.31
Ferrous sulphate	0.03	0.03	0.03
Sulphuric acid	0.03	0.03	0.03
Sodium hydroxide	0.04	0.04	0.04
Water	0.00	0.00	0.00
Waste management			
Transport	0.02	0.02	0.02
Inertization	0.11	0.11	0.11
Landfill	0.11	0.11	0.11
Personnel	4.00	4.00	4.00
Maintenance	1,20	1,08	1,49
<b>Total (€ m<sup>-3</sup>)</b>	<b>8,85</b>	<b>8,73</b>	<b>9,14</b>

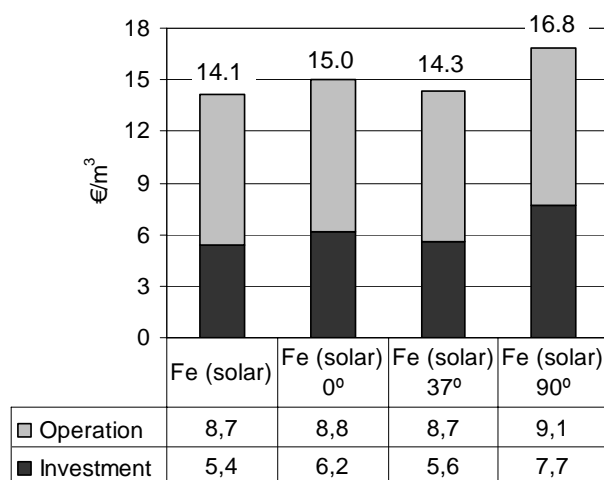

Figure 6.30. Overall cost of baseline and improved solar driven photo-Fenton.

It can be seen from figure 6.30 that the set of measures proposed tend to increase the cost of wastewater treatment. However, if the slope of the roof or facade approaches the optimum of 37°, it can be seen that the difference in cost is not significant. For a flat roof, cost increases by 6%, while for a vertical facade facing south it would increase by 19%. From the cost analysis, it can be seen that the increase in cost is mostly due to initial investment, and in particular to the photovoltaic system. Therefore, if conventional power supply was considered for a roof installation, no effect would be observed on overall cost with regard to a plant on the ground.

Another fact to consider from a qualitative point of view is that the cost assessment does not include land cost, as it has been considered to be already available at the industrial facility (not only land but also general services such as water and power supply). As a consequence, if this cost was taken into account in the assessment, probably the ground alternative would appear as the most expensive, or at least the differences would be much less significant.



### 6.8.6.2. Ozonation

For assessing the influence on cost of increasing ozone transfer efficiency, only the difference in operation costs has been taken into account, as the initial investment can be considered to be similar: increasing transfer efficiency requires an additional pump and hydroinjectors, as well as a second contact column, but on the other hand a smaller ozoniser can be used. The clearest influence on cost is thus due to less material and energy supplies (oxygen, cooling water, electricity, etc.). Table 6.42 shows the calculation of operation costs, while figure 6.31 compares the overall cost of baseline and improved ozonation. As can be seen, increasing transfer efficiency to 75% manifestly decreases the cost of wastewater treatment, namely by 13%, with regard to an initial transfer efficiency of 50%.

Table 6.45. Calculation of operation costs for improved ozonation.

Operation costs	O3 75%
Chemicals	
Oxygen	1.06
Sodium hydroxide	0.04
Power	1.18
Water	1.64
Personnel	4.00
Maintenance	0.90
<b>Total (€ m<sup>-3</sup>)</b>	<b>8.81</b>

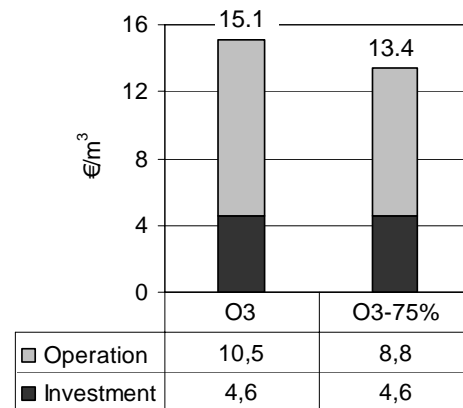

Figure 6.31. Overall cost of baseline and improved ozonation.

## 6.9. Integration of Environmental Impact and Cost

Sections 6.4 through 6.8 have been devoted to assess separately the environmental impact and the cost of the alternatives for wastewater treatment. There is an increasing interest, however, on ranking environmental aspects along with economic issues (Saling et al. 2002; Schmidt 2003; Bage and Samson 2003; Hunkeler and Biswas 2000). For this reason, both aspects are integrated here, using for this purpose an Eco-efficiency Index (*EEI*), which is defined below.

### 6.9.1. Definition of an Eco-efficiency Index

The basic premises under which the *EEI* has been defined are the following:

- Eco-efficiency is considered as the result of minimizing the binomial impact-cost,
- Environmental and economic aspects must receive the same weighting, meaning that decreasing the magnitude of impacts is as important as decreasing costs, but
- A higher Eco-efficiency not necessarily needs improving at the same time both aspects. For example, an alternative increasing cost by 10% and reducing impact by 20% is considered more eco-efficient, and viceversa.

From these premises, *EEI* is expressed as:

$$EEI = EEF_E + EEF_C; \quad 0 \leq EEI \leq 1 \quad (6.13)$$

Where:

$EEF_E$  is the environmental factor of *EEI*, and  
 $EEF_C$  is the cost factor of *EEI*.

$EEF_E$  and  $EEF_C$  are calculated as:

$$EEF_E = \frac{LCIA_{REL}}{2} \quad (6.14)$$

$$EEF_C = \frac{LCC_{REL}}{2} \quad (6.15)$$

Where:

$LCIA_{REL}$  is the life cycle impact of an alternative, relative to the alternative under study with the highest impact, and  
 $LCC_{REL}$  is the life cycle cost of an alternative, relative to the alternative under study with the highest life cycle cost.

Thus:

$$LCIA_{REL} = \frac{LCIA}{LCIA_{MAX}} \quad (6.16)$$

$$LCC_{REL} = \frac{LCC}{LCC_{MAX}} \quad (6.17)$$

Where:

$LCIA$  is the life cycle impact of an alternative ( $y \text{ m}^{-3}$ )

$LCIA_{MAX}$  is the life cycle impact of the alternative entailing the highest impact from the set of alternatives under study ( $y \text{ m}^{-3}$ ),

$LCC$  is the life cycle cost of an alternative ( $\text{€ m}^{-3}$ ), and

$LCC_{MAX}$  is the life cycle cost of the most expensive alternative under study ( $\text{€ m}^{-3}$ ).

The life cycle impact of an alternative is obtained in the LCA as a set of 9 indicator scores, namely the environmental profile. Nevertheless, in the  $EEI$  environmental impact is defined as unidimensional. Therefore normalization and weighting must be applied, in order to obtain a single impact score in ( $y \text{ m}^{-3}$ ).

## 6.9.2. Application of the Eco-efficiency Index to the alternatives under study

Table 6.46 shows the detailed calculation of all the parameters leading to  $EEI$  for all the baseline alternatives under study. Table 6.47 corresponds to the calculation of  $EEI$  for the improved versions of ozone and solar-driven photo-Fenton, while table 6.48 shows the calculation of  $EEI$  for solar-driven photo-Fenton in the range of  $UV_G$  values from 5 to 30  $W/m^2$ . Figures 6.32 to 6.34 display graphically the results of all these calculations.

Table 6.46. Calculation of the Eco-efficiency Index for all baseline alternatives and sensitivity analysis results on GAC adsorption.

EEI parameters	Ti (solar)	GAC	O3	GAC (S.A.)	Fe (lamp)	Fe (solar)
$LCIA$ ( $y \text{ m}^{-3}$ )	8.38E-11	5.86E-11	4,30E-11	3,22E-11	3,20E-11	2,39E-11
$LCC$ ( $\text{€ m}^{-3}$ )	67.3	14.6	15,1	14,6	12,1	14,1
$LCIA_{REL}$	1.000	0.699	0,512	0,384	0,381	0,285
$LCC_{REL}$	1.000	0.218	0,225	0,218	0,180	0,210
$EEF_E$	0.500	0.349	0,256	0,192	0,191	0,143
$EEF_C$	0.500	0.109	0,112	0,109	0,090	0,105
$EEI$	1.000	0.458	0,368	0,301	0,280	0,247

Table 6.47. Calculation of the Eco-efficiency Index for improved versions of ozonation and solar-driven photo-Fenton.

EEI parameters	O3 75%	Fe (solar) 0°	Fe (solar) 37°	Fe (solar) 90°
$LCIA$ ( $y \text{ m}^{-3}$ )	3.57E-11	2.28E-11	2.26E-11	2.35E-11
$LCC$ ( $\text{€ m}^{-3}$ )	13.4	15.0	14.3	16.8
$LCIA_{REL}$	0.426	0.272	0.270	0.280
$LCC_{REL}$	0.199	0.223	0.213	0.250
$EEF_E$	0.213	0.136	0.135	0.140
$EEF_C$	0.100	0.112	0.106	0.125
$EEI$	0.313	0.248	0.241	0.265

Table 6.48. Calculation of the Eco-efficiency Index for solar-driven photo-Fenton in a range of UV<sub>G</sub> values.

EEI parameters	UV <sub>G</sub> (W m <sup>-2</sup> )					
	5	10	15	20	25	30
LCIA (y m <sup>-3</sup> )	3,23E-11	2,65E-11	2,46E-11	2,37E-11	2,31E-11	2,27E-11
LCC (€ m <sup>-3</sup> )	27,6	18,2	15,1	13,5	12,5	11,9
LCIA <sub>REL</sub>	0,386	0,317	0,294	0,282	0,276	0,271
LCC <sub>REL</sub>	0,410	0,270	0,224	0,200	0,186	0,177
EEF <sub>E</sub>	0,193	0,158	0,147	0,141	0,138	0,135
EEF <sub>C</sub>	0,205	0,135	0,112	0,100	0,093	0,088
EEI	0,398	0,294	0,259	0,241	0,231	0,224

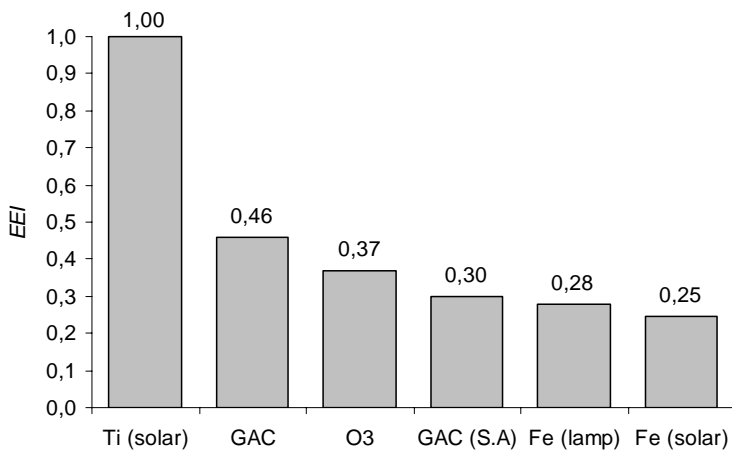

Figure 6.32. Eco-efficiency Index for all baseline alternatives.

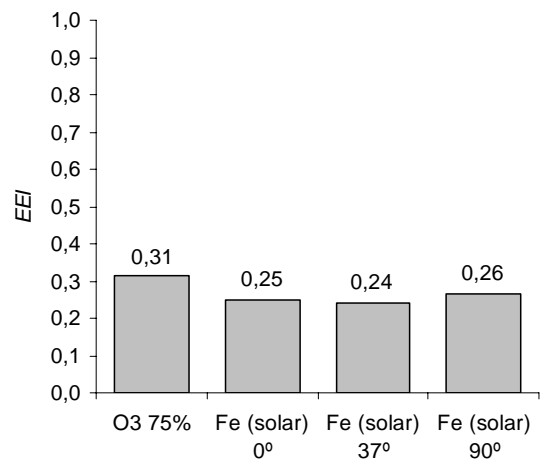

Figure 6.33. Eco-efficiency Index for improved versions of ozonation and solar-driven photo-Fenton.

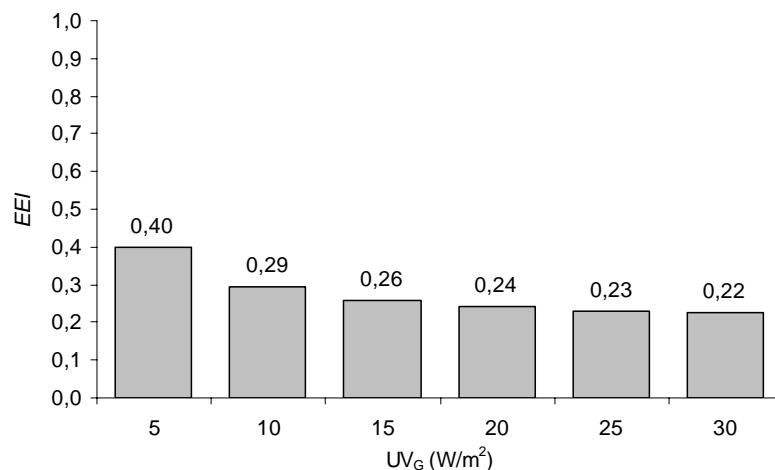

Figure 6.34. Eco-efficiency Index for solar-driven photo-Fenton in a range of UV<sub>G</sub> values.

From an integrated environmental-economic point of view, great differences appear between the alternatives for Femac wastewater treatment. Figure 6.32 shows that the least eco-efficient option is heterogeneous photocatalysis, which reaches the highest *EEI* score, 1. That means that it is at the same time the most expensive and least environmentally friendly alternative. The reference technology, GAC adsorption (*EEI* 0.46) is more eco-efficient than heterogeneous

photocatalysis, but it is the worst option when compared to ozonation and photo-Fenton, being the latter the most eco-efficient when solar light is used ( $EEI$  0.25). Nevertheless, if the  $EEI$  of GAC is built on the LCIA results of the sensitivity analysis, a figure of 0.3 is obtained, lower than that of ozonation and very close to that of lamp-driven photo-Fenton.

When the Eco-efficiency of measures for environmental improvement is investigated (figure 6.33), it can be seen that a clear advantage is obtained when ozone transfer efficiency is increased, since  $EEI$  decreases by 14%. On the other hand, the installation of a photovoltaic CPC field on the roof seems not to entail a clear eco-efficiency improvement, due to the trade-off between lower impact and higher cost.

Finally, it can be seen in figure 6.34 that eco-efficiency of solar-driven photo-Fenton decreases as the amount of UV radiation available decreases, since lower  $UV_G$  values imply higher impact and cost. When  $UV_G$  reaches  $10 \text{ W m}^{-2}$  lamp-driven photo-Fenton becomes more eco-efficient. On the other hand, increasing  $UV_G$  improves eco-efficiency but at a decreasing rate. For instance, increasing  $UV_G$  from  $20$  to  $30 \text{ W m}^{-2}$  (+50%) leads to an increase in eco-efficiency of 8% only ( $EEI$  decreases from 0.24 to 0.22).

## 6.10. Conclusions and Recommendations

Life Cycle Interpretation is the phase of the LCA in which the results of the analysis and all choices and assumptions made during the course of the analysis are evaluated in terms of soundness and robustness, and overall conclusions are drawn (ISO 2000). Several elements typically included in the interpretation phase, such as contribution analysis and sensitivity analysis have already been carried out through sections 6.4 to 6.8, whereas other elements which can be included in this phase are the consistency check, completeness check, perturbation analysis and uncertainty analysis (Guinée et al. 2002). The first two elements are considered to be properly developed through the Goal and Scope and Inventory Analysis sections (6.2 and 6.3). Perturbation analysis is skipped as this type of data treatment is not included in the software used (Simapro 6.0). Finally uncertainty analysis is not carried out due to lack of empirical data on the uncertainty ranges of the specific data used in the study. It has to be borne in mind, however, that both perturbation and uncertainty analysis are not mandatory elements of the interpretation phase.

Therefore, this section is reduced to drawing conclusions and recommendations, based on the information gathered in the previous phases of the environmental and economic study. Hence, it has been decided to structure this section as a set of answers to the particular research questions formulated in the Goal section (6.2.1).

### 6.10.1. Performance of the treatments developed in the CADOX project

Three alternatives have been studied in the CADOX project at the pilot-plant scale for treatment of Femac:

- Solar-driven photo-Fenton coupled to biotreatment
- Solar-driven heterogeneous photocatalysis coupled to biotreatment
- Ozonation coupled to biotreatment

The results of the Life Cycle Impact assessment show that heterogeneous photocatalysis entails the highest environmental impact in all indicators (global warming emissions 5 and 1.5 times higher than photo-Fenton and ozonation respectively; energy consumption 6 times and 1.2 times higher than photo-Fenton and ozonation respectively). The lowest environmental impact corresponds to solar-driven photo-Fenton, which performs better in all indicators except in human toxicity, where ozonation achieves the lowest impact. The environmental impact of ozonation falls between that of the remaining alternatives.

With regard to economic performance, heterogeneous photocatalysis appears as the most expensive alternative (67 € m<sup>-3</sup>), while the cost of solar-driven photo-Fenton and ozonation is similar, being that of photo-Fenton lower (14 € m<sup>-3</sup>) as compared to ozonation (15 € m<sup>-3</sup>).

### 6.10.2. Performance of solar-driven AOPs as compared to lamp-driven AOPs

Only an AOP has been included in the study as using artificial UV light, namely lamp-driven photo-Fenton coupled to biotreatment. It has to be borne in mind, however, that this alternative has been assessed in the study without specific experimental data from the CADOX project. As a consequence, the results must be interpreted carefully.

In general terms, solar-driven photo-Fenton appears as a preferable option when compared to lamp-driven photo-Fenton. In 6 impact indicators the solar alternative obtains better results (as an example, for the lamp-driven alternative global warming emissions are twofold and energy consumption is threefold), while in 3 indicators obtains similar results.

However using solar light as source of photons is not always justified, even from an environmental point of view, as the environmental impact of solar-driven heterogeneous photocatalysis is much higher than that of lamp-driven photo-Fenton (global warming emissions 2.5 times higher; energy consumption 2 times higher).

From an economic point of view, the results are different: lamp-driven photo-Fenton entails a lower cost (12 €/m<sup>3</sup>) than both solar-driven AOPs. However, the cost of solar-driven photo-Fenton (14 € m<sup>-3</sup>) does not deviate as much as that of heterogeneous photocatalysis (67 € m<sup>-3</sup>).

### 6.10.3. Performance of the CADOX technology as compared to conventional technologies

The reference technology chosen in the case study is GAC adsorption. An important limitation has been encountered in the study in order to assess this option, due to the lack of default inventory data in the Ecoinvent database concerning GAC production and regeneration. This problem has been solved by building the inventory by means of literature data, and performing a sensitivity analysis in order to check the robustness of the results.

When the AOPs developed in the CADOX project are compared to carbon adsorption on the basis of Femac treatment, the only alternative appearing as environmentally preferable in most impact categories is solar-driven photo-Fenton. However, if the energy requirements to reactivate carbon are high enough (around 100 MJ natural gas kg<sup>-1</sup> carbon), then ozonation and lamp-driven photo-Fenton would score better than carbon adsorption in all indicators. It has to be highlighted that carbon adsorption has been assessed assuming regeneration, whereby only small amounts of carbon are consumed. The differences in environmental impact would probably be more important if carbon was sent to incineration, as the amount of carbon that must be consumed is 10 times higher.

From an economic point of view, all the AOPs assessed are competitive (solar-driven photo-Fenton: 14 € m<sup>-3</sup>; ozonation: 15 € m<sup>-3</sup>; lamp-driven photo-Fenton: 12 € m<sup>-3</sup>) with regard to carbon adsorption (15 € m<sup>-3</sup>). Heterogeneous photocatalysis is the exception, as it is the most expensive alternative in the study (67 € m<sup>-3</sup>).

### 6.10.4. Processes contributing in a significant manner to the life cycle

The environmental impact of solar-driven photo Fenton is dominated by hydrogen peroxide consumption during operation (50% of energy consumption) and by the materials used to build the 100 m<sup>2</sup> CPC field (30-40% of contribution to toxicity indicators). The main economic costs of this alternative are capital costs (38%), personnel (28%) and hydrogen peroxide (23%).

The main process contributing to the life cycle impact of heterogeneous photocatalysis are the materials used to build the 2,150 m<sup>2</sup> CPC field (60% of global warming emissions, 90% of contribution to toxicity indicators). Secondly there is the energy consumed during operation for pumping of the wastewater (30% of global warming emissions; 45% of energy consumption), an aspect directly related to the extension of the solar field. The main economic costs of this alternative are capital costs (77%) and maintenance costs (15%).

The environmental impact of ozonation is mainly due to consumption of electricity (60% of energy consumption; 50% of global warming emissions) and oxygen to produce ozone (30% of energy consumption, 25% of global warming emissions). The environmental impact of infrastructure has been excluded from the study as it is considered to be negligible in environmental terms. The economic cost of ozonation is dominated by capital costs (30%), personnel (26%), cooling water (16%), power and oxygen (21% together).

Lamp-driven photo-Fenton is dominated in the contribution analysis by the impact of electricity consumption due to lamp irradiation (75% of energy consumption; 60% of global warming emissions), but also by hydrogen peroxide consumption (60% of contribution to human toxicity; 35% to ecotoxicity). The environmental impact of infrastructure has been excluded from the study as it is considered to be negligible in environmental terms. The economic cost of this alternative is mainly influenced by personnel costs (36%), hydrogen peroxide (27%) and lamp replacement (18%).

In all the alternatives discussed above, coupling to biological treatment appears to have a low influence on the environmental impact, except in the eutrophication potential, where biotreatment represents about 50% in heterogeneous photocatalysis, 80% in ozonation and 90% in lamp- or solar-driven photo-Fenton. This influence is caused by the remaining nitrogen (ammonium and nitrate) discharged by the sewage plant to the aquatic recipient. On the other hand, the cost of biotreatment has not been assessed in the study due to lack of data.

The environmental impact of activated carbon adsorption is mainly due to production of the carbon and the regeneration process. The relative contribution of each process to the overall impacts depends on the inventory data used, as has been demonstrated in a sensitivity analysis. The environmental impact of infrastructure has been excluded from the study as it is considered to be negligible in environmental terms. Finally, the economic cost of this alternative is dominated by carbon regeneration (49%), personnel (26%) and capital costs (20%).

### 6.10.5. Influence of UV radiation available on solar AOPs performance

The environmental implications of changes in the amount of solar UV light available have been assessed only for the photo-Fenton process. The impact has been assessed as weighted score; this means that the detailed effect on each impact indicator has not been evaluated.

The weighted impact of solar-driven photo-Fenton tends to increase as less solar UV resources are available. Nevertheless, it is estimated that even in northern Europe enough solar light is available to justify from an environmental point of view the application of photo-Fenton with regard to the other alternatives: lamp-driven photo-Fenton, ozonation and carbon adsorption. On the other hand, increasing the availability of UV light, with regard to that of Almeria, does not represent a significant environmental improvement.

Concerning the economic consequences of less solar UV light available, it is observed a sharp increase in cost. In locations where less than 15 W-UV m<sup>-2</sup> are available, either ozonation or carbon adsorption are more attractive. At the same time, for solar-driven photo-Fenton becoming cheaper than the same process using lamps, at least 30 W-UV m<sup>-2</sup> are required, although nowhere in Europe such a value can be expected.



### 6.10.6. Measures for environmental improvement and their consequences on cost

Measures for environmental improvement of solar-driven photo-Fenton and ozonation alternatives have been proposed and their life cycle impact have been evaluated, along with changes in costs.

For solar-driven photo-Fenton, the following measures have been proposed and evaluated:

- Installation of the CPCs on the roof of the industrial facility, laying parallel to the roof slope, or hanging on the facade.
- Installation of a photovoltaic system for autonomous supply of electricity.

These measures entail a reduction of the environmental impact in the range of 10-15%, depending on the impact indicator considered. The impact on land use, however, is reduced by 50%, as the ground previously used to install the CPC field is now left free. On the other hand, these measures tend to increase the cost of wastewater treatment (19% when installing on the facade, 6% on a flat roof), but this is due mainly to the cost of the photovoltaic system and not to installing the CPCs on the roof. These set of measures are only suggestions addressed to future applications, and have not been implemented in the demonstration plant.

For ozonation, the following measure has been proposed and evaluated:

- Optimize ozone transfer efficiency by recirculating ozone in the off-gas of the contact column to a second contact column using a hydroinjector. This allows to increase transfer efficiency from 50% to 75%.

This strategy decreases the environmental impact of ozonation by about 25% in all indicators. This impact reduction allows ozonation to be closer in environmental terms to lamp-driven photo-Fenton. In addition, the overall cost of ozonation is reduced by 13%. This strategy has been suggested and applied by Trailigaz in the design of the ozone system to be installed in the demonstration plant.

### 6.10.7. Integrated environmental-cost assessment

An Eco-efficiency Index (*EEI*) has been defined, which integrates environmental as well as economic performance and allows to compare a set of alternatives in relative terms. *EEI* takes values between 0 and 1, being the lower values synonymous of higher eco-efficiency (minimisation of the binomial impact-cost), and viceversa.

The application of *EEI* to the alternatives under study shows that heterogeneous photocatalysis is the least eco-efficient option, obtaining the maximum *EEI* value of 1, meaning that it is at the same time the most expensive and least environmentally friendly. Carbon adsorption (*EEI* 0.46) is more eco-efficient than heterogeneous photocatalysis, but it is the worst option when compared to ozonation (*EEI* 0.37) and photo-Fenton, being the latter the most eco-efficient when solar light is used (*EEI* 0.25) instead of lamps (*EEI* 0.28). Nevertheless, if the *EEI* of GAC is built on the results of the sensitivity analysis (*EEI* 0.30), a lower figure than that of ozonation and very close to that of lamp-driven photo-Fenton is obtained.

When the eco-efficiency of measures for environmental improvement is investigated, a clear advantage is obtained when ozone transfer efficiency is increased, since *EEI* decreases by 14% (from 0.37 to 0.31). On the other hand, the installation of a CPC field on the roof along with a photovoltaic system seems not to entail a clear eco-efficiency improvement, due to the trade-off between lower impact and higher cost.

Eco-efficiency of solar-driven photo-Fenton decreases as the amount of UV radiation available decreases, since lower solar resources imply higher impact and above all higher cost. When less than 10 W-UV/m<sup>2</sup> are available, lamp-driven photo-Fenton becomes more eco-efficient. On the other hand, increasing solar intensity from 20 to 30 W-UV m<sup>-2</sup> (+50%) leads to an increase in eco-efficiency of 8% only (*EEI* decreases from 0.24 to 0.22).

It has to be borne in mind, however, that the eco-efficiency concept does not substitute the separate environmental and cost assessment. It is up to the decision maker to decide whether the determining criteria is environmental, economic, or both integrated in a wider multicriteria assessment including other relevant parameters, such as technical feasibility, risk, and social issues.

#### 6.10.8. Final ranking of alternatives

As final summary, the schema shown in the next page is an attempt to synthesize the results obtained in the study, following a semiquantitative approach. Each staircase represents a ranking in which all the alternatives (baseline and improved) under study for Femac treatment are included. There is an environmental ranking, as well as an economic and eco-efficiency ranking. The higher the position of an alternative, the better its performance. Alternatives in the same stair involve quite small differences with each other, being preferable from left to right.

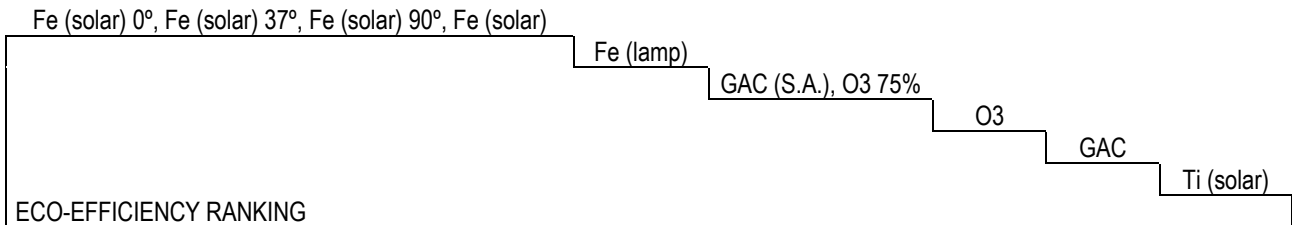
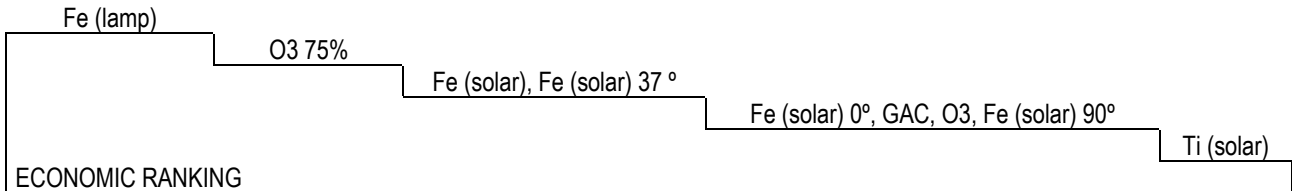
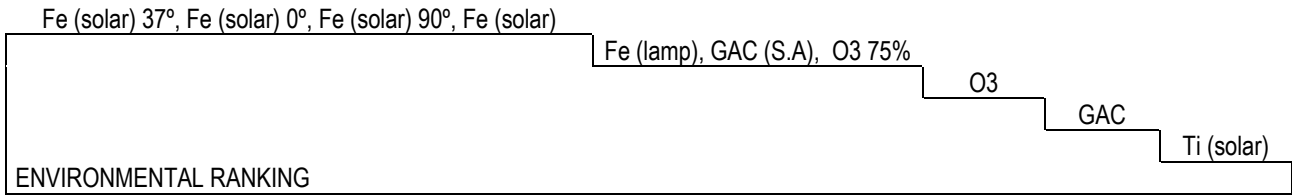

Acronyms:

Fe (solar)	Solar-driven photo-Fenton coupled to biological treatment.
Fe (solar) 37°	Solar-driven photo-Fenton coupled to biological treatment, CPCs installed on a roof tilted 37° with autonomous photovoltaic system.
Fe (solar) 0°	Solar-driven photo-Fenton coupled to biological treatment, CPCs installed on a flat roof with autonomous photovoltaic system.
Fe (solar) 90°	Solar-driven photo-Fenton coupled to biological treatment, CPCs installed on a facade facing south with autonomous photovoltaic system.
Fe (lamp)	Lamp-driven photo-Fenton.
O3	Ozonation coupled to biological treatment.
O3 75%	Ozonation coupled to biological treatment, ozone transfer efficiency increased from 50% to 75%.
Ti (solar)	Solar-driven heterogeneous photocatalysis coupled to biological treatment.
GAC	Granular activated carbon adsorption.
GAC (S.A.)	Granular activated carbon adsorption, results obtained in the sensitivity analysis.

### 6.10.9. Recommendations and outlook

Based on the results of the study, a few recommendations are given, addressed to the CADOX project partners in particular, and to the researchers in the field of AOPs in general.

- ✓ The clearest “front-runner” alternative from those assessed, in environmental terms, is solar-driven photo-Fenton. In addition, its cost is competitive if enough solar UV irradiation is available (more than 15 W-UV m<sup>-2</sup>). Therefore, solar-driven photo-Fenton should be the most promoted technology by the CADOX project.
- ✓ Although solar-driven photo-Fenton is a clean technology with regard to energy use, it has to be borne in mind that it involves a considerable consumption of hydrogen peroxide, which causes the greatest share of the life cycle impact. It is suggested that full-scale units applying this AOP should incorporate an hydrogen peroxide sensor, which allows to monitor the concentration of this chemical in the reactor, thus helping to avoid the addition of excess amounts.
- ✓ Installation of the CPC field in a solar photocatalytic plant for water detoxification appears to have environmental benefits when done on the roof or the facade of an industrial facility, instead of on the ground. In addition, it does not entail higher costs if conventional power supply is considered. For this reason, this alternative must be encouraged, leaving up to the decision maker the possibility of also installing a photovoltaic system for autonomous power supply, which is encouraged in environmental terms, but increases the investment costs.
- ✓ The possibility of a photocatalytic wastewater treatment plant using the sun not only as a source of photons but also of electricity, has been evaluated in the study, but considering separate CPC and photovoltaic systems. An interesting alternative to this is the integrated helio-photocatalytic–photovoltaic hybrid system for simultaneous water decontamination and solar energy conversion (Blanco et al. 2004b). This system, which is at present in development by EPFL, PSA and Universidad de los Andes (Sarrià et al. 2005), should be subject to a LCA-LCC study in order to ascertain the potential environmental and economic benefits of its application.
- ✓ The poor environmental as well as economic performance of solar-driven heterogeneous photocatalysis is one of the most surprising conclusions of the study, given that heterogeneous photocatalysis is an AOP that has attracted the attention of researchers for many years. The degradation of target pollutants by this process is very slow, not only with Femac but also when mixtures of pesticides have been tested in the CADOX project. This low degradation rate of pollutants implies a high CPC area for a full-scale unit, which in turn entails high environmental impact and cost. The question that arises is whether the experimental conditions used in the CADOX project were optimized, and here a special remark is made to pH. It is suggested that optimizing pH conditions could improve the performance of heterogeneous photocatalysis, something that should be taken into account in future projects. It is also important to remark that heterogeneous photocatalysis, according to the literature, can be competitive as compared to photo-Fenton when wastewaters having lower concentration of pollutants (in the range of a few mg/litre) must be treated (Malato et al. 2003), and when the target pollutant is not aromatic (Fernández-Alba 2002). It seems, then, that heterogeneous photocatalysis is not a good option in the context of the CADOX project, but could be for other applications.
- ✓ Concerning lamp-driven photo-Fenton, experimental data from pilot-plant tests should be required in order to assess this alternative properly. The assessment carried out in this study is nothing but an estimation, which does not allow to decide if this alternative is preferable to ozonation from an environmental point of view.

## List of symbols

$A$	Autonomy of a power storage system (days)
$BC$	Battery capacity (Ah)
$C$	Concentration of solute remaining in solution at equilibrium ( $\text{mg l}^{-1}$ )
$c$	Light speed ( $2.998 \cdot 10^8 \text{ m s}^{-1}$ )
$C_{CPC}$	Unitary cost of a solar photocatalytic plant per unit CPC area ( $\text{€ m}^{-2}$ ), excluding control equipment and terrain preparation
$COST$	Total cost of a plant or equipment ( $\text{€}$ )
$CRF$	Capital Recovery Factor ( $\text{year}^{-1}$ )
$D_{MAX}$	Maximum allowed discharge depth of a battery (%)
$E_{DAY}$	Average daily electricity to be produced by the photovoltaic system ( $\text{kWh day}^{-1}$ )
$EEF_C$	Cost component of the Eco-efficiency Index
$EEF_E$	Environmental component of the Eco-efficiency Index
$EI$	Eco-efficiency Index
$E_{LAMP}$	Electricity consumed by a UV lamp to irradiate wastewater ( $\text{kWh m}^{-3}$ )
$E_{PUMP}$	Electricity consumed for pumping in a solar photocatalytic plant ( $\text{kWh m}^{-3}$ )
$h$	Planck's constant ( $6.626 \cdot 10^{-34} \text{ J s}$ )
$IC$	Total investment cost of a wastewater treatment plant ( $\text{€}$ )
$K$	Constant that must be determined for each solute, carbon type and temperature
$kW_A$	Pump power at the Albaida plant (kW)
$kW_{LAMP}$	UV lamp power (kW)
$kW_p$	Peak power of a photovoltaic panel (kW)
$\lambda_{UV,LAMP}$	UV lamp peak emission wavelength (m)
$LCC$	Life cycle cost of an alternative ( $\text{€ m}^{-3}$ )
$LCC_{MAX}$	Life cycle cost of the most expensive alternative from a set of alternatives ( $\text{y m}^{-3}$ )
$LCC_{REL}$	Life cycle cost of an alternative, relative to the alternative with the highest life cycle cost
$LCIA$	Weighted life cycle impact of an alternative ( $\text{y m}^{-3}$ )
$LCIA_{MAX}$	Weighted life cycle impact of the alternative entailing the highest impact in a set of alternatives ( $\text{y m}^{-3}$ )
$LCIA_{REL}$	Life cycle impact of an alternative, relative to the alternative with the highest impact
$LU_{PLANT}$	overall land use of the plant per $\text{m}^3$ wastewater treated ( $\text{m}^2 \text{ year m}^{-3}$ )
$M$	Mass of adsorbent (g)
$n$	Constant that must be determined for each solute, carbon type and temperature
$N$	Study period (years)
$N_{LAMP,m^2}$	Equivalency factor between lamps and CPC area (lamp units/ $\text{m}^2$ CPC)
$n_{LAMP}$	UV photon supply rate by a UV lamp ( $\text{photons hour}^{-1}$ )
$N_M$	Number of photovoltaic modules (units)
$OC$	Yearly operating cost of the wastewater treatment plant ( $\text{€ year}^{-1}$ )
$psh$	Daily peak sun hours, or average number of $\text{kWh m}^{-2} \text{ day}^{-1}$ received at the site
$PV$	Total cost of a photovoltaic system ( $\text{€}$ )
$Q_{UV}$	Accumulated UV radiation needed by a photocatalytic reactor to reach a given level of pollutant removal ( $\text{J/litre}$ )
$r$	Interest or (discount) rate (%)
$S_{CPC}$	Area of CPC aperture in a solar photocatalytic plant ( $\text{m}^2$ )
$S_{CPC,A}$	Area of CPC aperture in the Albaida plant ( $\text{m}^2$ )
$SIZE$	Total size (capacity, volume, etc.) of a plant or equipment

<i>SPV</i>	Single Present Value factor (%)
<i>TC</i>	Total unitary cost of wastewater treatment (€ m <sup>-3</sup> )
<i>T<sub>LAMP</sub></i>	Operation time of a lamp-driven plant (hours year <sup>-1</sup> )
<i>T<sub>SUN</sub></i>	Yearly operation time of a solar photocatalytic plant (hours year <sup>-1</sup> )
<i>UV<sub>G</sub></i>	Yearly global average UV irradiation, sunrise to sunset, at plant site (W m <sup>-2</sup> )
<i>UV<sub>n</sub></i>	Average UV radiation measured by the pilot plant radiometer during $\Delta t$ (Wm <sup>-2</sup> )
<i>V</i>	Wastewater volume to be treated in a year (m <sup>3</sup> year <sup>-1</sup> )
<i>V<sub>T</sub></i>	Total pilot plant volume (litres)
<i>Volt</i>	Voltage of a battery (V)
<i>W<sub>UV,LAMP</sub></i>	Lamp power in the UV range (W)
<i>X</i>	Amount of solute adsorbed (mg)

## References to Chapter 6

- AGBAR. 1995. *La regeneració del carbó actiu a l'estació de tractament de Sant Joan Despí*. Societat General d'Aigües de Barcelona.
- Alexiadis A, Mazzarino I. 2005. *Design guidelines for fixed-bed photocatalytic reactors*. Chemical Engineering and Processing, 44, pp. 453-459.
- Bage G, Samson R. 2003. *The Econo-Environmental Return (EER). A link between environmental impacts and economic aspects in a life cycle thinking perspective*. International Journal of Life Cycle Assessment, 8 (4), pp. 246-251.
- Bala J. 2005. *Personal communication*. Obres i construccions Josep Bala. Sant Climent de Llobregat, Spain.
- Bare J C, Hofstetter P, Pennington D W, Udo de Haes H A. 2000. *Life Cycle Impact Assessment Workshop Summary. Midpoints versus Endpoints: The Sacrifices and Benefits*. International Journal of Life Cycle Assessment, 5 (6) pp. 319-326.
- Bayer P, Heuer E, Karl U, Finkel M. 2005. *Economical and ecological comparison of granular activated carbon (GAC) adsorbers refill strategies*. Water Research, 39, pp. 1719-1728.
- Becker D L, Wilson S C. 1978. *The use of activated carbon for the treatment of pesticides and pesticidal wastes*. In Cheremisinoff P N, Ellerbusch F. (Eds). *Carbon Adsorption Handbook*. Ann Arbor Science, Michigan.
- Bez J, Goldhan G, Heyde M. 1998. *Waste treatment in product specific life cycle inventories. An approach of material-related modelling. Part II: Sanitary Landfill*. International Journal of Life Cycle Assessment, 3 (2), pp. 100-105.
- Blanco J, Malato S, Nieves J de las, Fernández P. 2001. *Method of sedimentation of colloidal semiconductor particles*. European Patent Office. EP 1 101 737 A1. Bulletin 2001/21.
- Blanco J. 2002. *Desarrollo de colectores solares CPC para aplicaciones fotoquímicas de degradación de contaminantes persistentes en agua*. Doctoral thesis. Ed. CIEMAT, Madrid.
- Blanco J, Malato S. 2003. *Solar Detoxification*. UNESCO Publishing, France.
- Blanco J, Malato S, Maldonado M I, Vincent M, Vincent J P, Sánchez M, Myro E. 2004a. *The Albaida plant: first commercial step in solar detoxification*. Global Symposium on Recycling, Waste Treatment and Clean Technology, REWAS'04, Madrid, Spain.
- Blanco J, Malato S, Pulgarín C, Sarria V, Kenfack S. 2004b. *Dispositivo Integrado para descontaminación de agua y producción de energía eléctrica*. Oficina Española de Patentes y Marcas, nº P200401376. Solicitante: CIEMAT y École Polytechnique de Laussane (Suisse).
- Carrera J. 2005. *Personal communication*. Chemical Engineering Department, Universitat Autònoma de Barcelona, Spain.
- Catalan Water Agency. 2005. *El Cànon de l'aigua i altres tributs. Usos industrials i assimilables*. Online documentation: [http://mediambient.gencat.net/aca/ca/agencia/canon/usos\\_industrials.jsp](http://mediambient.gencat.net/aca/ca/agencia/canon/usos_industrials.jsp)
- Clift R. 2005. *Integrating LCA and process flowsheeting to analyse industrial ecosystems*. Presented at the Seminar on Energy and Industrial Ecology. Norwegian University of Science and Technology, 11 may, Trondheim.
- Cortés-Russell D. 2005. *Personal communication*. Aguas de Levante S.A. Barcelona, Spain.
- Dalemo M. 1997. *The ORWARE simulation model. Anaerobic digestion and sewage plant sub-models*. Licentiate thesis. Swedish Institute of Agricultural Engineering, Swedish University of Agricultural Sciences (SLU), Uppsala. AFR-report 152, Swedish Environmental Protection Agency.
- Derwent, R G, Jenkin M E, Saunders S M, Pilling M J. 1998. *Photochemical ozone creation potentials for organic compounds in Northwest Europe calculated with a master chemical mechanism*. Atmospheric environment, 32. pp. 2429-2441.
- Diputació de Barcelona. 2005. *Mercat dels materials recollits a les deixalleries – estat dels preus*. Online document. <http://www.diba.es/mediambient/mercatsub.asp>

- Dixon A, Simon M, Burkitt T. 2003. *Assessing the environmental impact of two options for small-scale wastewater treatment: comparing a reedbed and an aerated biological filter using a life cycle approach*. *Ecological Engineering*, 20, pp. 297-308.
- Doka G. 2003. *Life Cycle Inventories of Waste Treatment Services*. Final report ecoinvent 2000 No. 13, EMPA St. Gallen, Swiss Centre for Life Cycle Inventories, Duebendorf, Switzerland.
- Domínguez R. 2005. *Personal communication*. Environmental manager, MASA Decor, S.A. Sant Pere de Vilamajor, Barcelona, Spain.
- Eckenfelder W W. 1989. *Industrial Water Pollution Control*. 2nd Ed. McGraw-Hill, New York, USA.
- EEA. 1999. *Guidelines for defining and documenting data on costs of possible environmental protection measures*. Technical report nº 27. Copenhagen, Denmark.
- EIPPCB. 2005. *Integrated pollution prevention and control. Reference document on economics and cross-media effects*. European Commission European IPPC Bureau, Seville, Spain. <http://eippcb.jrc.es>
- EU. 1975. *Council Directive 75/440/EEC of 16 June 1975 concerning the quality required of surface water intended for the abstraction of drinking water in the Member States*. Official Journal L 194, 25/07/1975. pp. 0026 – 0031.
- EU. 1996. *Council Directive 96/61/EC of 24 September 1996 concerning integrated pollution prevention and control*. Official Journal L 257, 10/10/1996. pp. 0026 – 0040.
- EU. 2001. *Decision No 2455/2001/EC of the European Parliament and of the Council of 20 November 2001 establishing the list of priority substances in the field of water policy and amending Directive 2000/60/EC*. Official Journal L 331, 15/12/2001. pp. 0001 – 0005.
- EU. 2002. *Directive 2002/95/EC of the European Parliament and of the Council of 27 January 2003 on the restriction of the use of certain hazardous substances in electrical and electronic equipment*. Official Journal L 037, 13/02/2003. pp. 0019 – 0023.
- EU. 2005. *PVGIS: Map-based Assessment of Solar Energy Resource*. Institute for Environment and Sustainability, Renewable Energies Unit. Online application available at : <http://re.jrc.cec.eu.int/pvgis/pv/index.htm>
- Fernández-Alba A R, Hernando D, Agüera A, Cáceres J, Malato S. 2002. *Toxicity assays: a way for evaluating AOPs efficiency*. *Water Research*, 36, pp. 4255-4262.
- Fernández-Ibáñez P, Blanco J, Malato S, de las Nieves F J. 2003. *Application of the colloidal stability of TiO<sub>2</sub> particles for recovery and reuse in solar photocatalysis*. *Water Research*, 37, pp. 3180-3188.
- Fernández-Ibáñez P, Malato S, de las Nieves F J. 2004. *Propiedades coloidales de partículas de TiO<sub>2</sub>: aplicación al tratamiento fotocatalítico solar de aguas*. Ed. CIEMAT, Madrid.
- Frischknecht R, Heijungs R, Hofstetter P. 1998. *Einstein's lessons for energy accounting in LCA*. *International Journal of Life Cycle Assessment*, 3 (5), pp. 266-272.
- Frischknecht R, Althaus H J, Doka G, Dones R, Heck T, Hellweg S, Hirschier R, Jungbluth N, Nemecek T, Rebitzer G, Spielmann M. 2004. *Overview and Methodology*. Final report ecoinvent 2000 No. 1, Swiss Centre for Life Cycle Inventories, Duebendorf, Switzerland. [www.ecoinvent.ch](http://www.ecoinvent.ch)
- Fuller S K, Petersen S R. 1996. *Life-Cycle Costing Manual for the Federal Energy Management Program*. National Institute of Standards and Technology, Handbook 135. Prepared for U.S. Department of Energy. Washington DC. Available at: [www.eere.energy.gov/femp/program/lifecycle.cfm](http://www.eere.energy.gov/femp/program/lifecycle.cfm)
- Gaterell M R, Lester J N. 2000. *Establishing the true costs and benefits of environmental protection and enhancement in the aquatic environment*. *The Science of the Total Environment*, 249, pp. 25-37.
- Generalitat de Catalunya. 2003. *Decret 130/2003, de 13 de maig, pel qual s'aprova el Reglament dels serveis públics de sanejament*. Diari Oficial de la Generalitat de Catalunya nº 3894 – 29.5.2003, 11143-11158.
- Gernjak W. 2005. *Personal communication*. Plataforma Solar de Almería, CIEMAT, Spain.



- Guinée J B, Gorree M, Heijungs R, Huppes G, Kleijn R, Udo de Haes H A, Van der Voet E, Wrisberg M N. 2002. *Life Cycle Assessment. An operational guide to ISO standards*. Volume 1, 2, 3. Centre of Environmental Science, Leiden University (CML), The Netherlands.
- Hauschild M, Wenzel H. 1998. *Environmental Assessment of Products*. Vol. 2: Scientific background. Chapman & Hall.
- Heijungs R, Guinée J, Huppes G, Lankreijer R M, Udo de Haes, E, Wegener A, Anselms A, Eggels P G, Van Duin R, Goede H P. 1992. *Environmental Life Cycle Assessment of Products. Guide and Backgrounds*. Centre of Environmental Science, Leiden University (CML), Leiden University, The Netherlands.
- Hernández J. 2005. *Personal communication*. Operative, Albaida Recursos Naturales y Medio Ambiente S.L. Almería, Spain.
- Hirvonen A, Tuhkanen T, Ettala M, Korhonen S, Kalliokoski P. 1998. *Evaluation of a field-scale UV/H<sub>2</sub>O<sub>2</sub>-oxidation system for the purification of groundwater contaminated with PCE*. *Environmental Technology*, 19, pp. 821-828.
- Houghton J T, Meira Filho L G, Bruce J, Lee H, Callander B A, Haites E, Harris N, Maskell K (Eds). 1994. *Climate change 1994. Radiative forcing of climate change an evaluation of the IPCC IS92 Emissions scenarios*. Cambridge University Press, Cambridge.
- Houghton J T, Meira Filho L G, Callander B A, Harris N, Maskell K, Kattenberg A (Eds.). 1995. *Climate change 1995. The science of climate change*. Contribution of WGI to the second assessment report of the intergovernmental panel on climate change. Cambridge University Press, Cambridge.
- Huijbregts M A J, Thissen U, Guinée J B, Jager T, Kalf D, van de Meent D, Ragas A M J, Wegener Sleeswijk A, Reijnders L. 2000. *Priority assessment of toxic substances in life cycle assessment. Part I: Calculation of toxicity potentials for 181 substances with the nested multi-media fate, exposure and effects model USES-LCA*. *Chemosphere* 41 (4), pp. 541-573.
- Hunkeler D, Biswas G. 2000. *Return on environment. An objective indicator to validate life cycle assessments?*. *International Journal of life cycle assessment*, 5 (6) pp. 358-362.
- Huppes G, Schneider F (Eds.). 1994. *Proceedings of the European Workshop on Allocation in LCA*. Centre of Environmental Science of Leiden University, Section Substances & Products. Leiden 24-25 feb. 1994.
- Hutchins, R A. 1975. *Thermal regeneration costs*. *Chemical Engineering Progress*, 71 (5), pp. 80-86.
- ICAEN. 2002. *Curs de formació. Energia solar fotovoltaica*. Available at [www.icaen.net](http://www.icaen.net).
- IDAE. 1996. *Manuales de energías renovables. Vol. 6: energía solar fotovoltaica*. Biblioteca Cinco Dias. Madrid, Spain.
- Inelsacontrols. 2005. [www.inelsacontrols.com](http://www.inelsacontrols.com)
- IPCC. 1997. *IPCC Guidelines for National Greenhouse Gas Inventories*. Three Volumes. [www.ipcc.ch](http://www.ipcc.ch)
- ISO. 1997. *ISO 14040: Environmental management – Life cycle assessment – Principles and Framework*. Geneva, Switzerland.
- ISO. 1998. *ISO 14041: Environmental management – Life cycle assessment – Goal and Scope Definition and Inventory Analysis*. Geneva, Switzerland.
- ISO. 1999. *ISO 14042: Environmental management – Life cycle assessment – Life Cycle Impact Assessment*. Geneva, Switzerland.
- ISO. 2000. *ISO 14043: Environmental management – Life cycle assessment – Life Cycle Impact Interpretation*. Geneva, Switzerland.
- Jenkin M E, Hayman G D. 1999. *Photochemical ozone creation potentials for oxygenated volatile organic compounds: sensitivity to variations in kinetic and mechanistic parameters*. *Atmospheric environment*, 33, pp. 1275-1293.
- Jenseit W, Stahl H, Wollny V, Wittlinger R. 2003. *Recovery Options for Plastic Parts from End-of-Life Vehicles: an Eco-Efficiency Assessment*. Prepared by Öko-Institut e.V. for APME. Darmstadt, Deutschland.
- Jolliet O, Müller-Wenk R, Bare J, Brent A, Goedkoop M, Heijungs R, Itsubo N, Peña C, Pennington D, Potting J, Rebitzer G, Stewart M, Udo de Haes H, Weidema B. 2004. *The LCIA Midpoint-damage Framework of the UNEP/SETAC Life Cycle Initiative*. *International Journal of Life Cycle Assessment*, 9 (6), pp. 394-404.

- Jungbluth N. 2004a. *Photovoltaik*. In: Dones R, Bauer C, Burger B, Faist M, Frischknecht R, Heck T, Jungbluth N, Röder A. . *Sachbilanzen von Energiesystemen: Grundlagen für den ökologischen Vergleich von Energiesystemen und den Einbezug von Energiesystemen in Ökobilanzen für die Schweiz*. Final report ecoinvent 2000 No. 6, Paul Scherrer Institut Villigen, Swiss Centre for Life Cycle Inventories, Switzerland.
- Jungbluth N. 2004b. *Life Cycle Assessment for emerging technologies: case studies for photovoltaic and wind power*. International Journal of Life Cycle Assessment 10 (1) pp. 24-34.
- Jungbluth N. 2005. *Life cycle assessment of crystalline photovoltaics in the Swiss ecoinvent database*. Progress in Photovoltaics: Research and Applications, 13 (5), pp. 429-446.
- Klausner J F, Goswami Y D, Wyness P R. 1992. *Energy consumption of wastewater treatment technologies*. Proceedings of the ASME International Solar Energy Conference, Vol. 1, pp. 29-36.
- Link H, Turchi C. 1991. *Cost and performance projections for solar water detoxification systems*. Prepared for American Society of Mechanical Engineers (ASME), International Solar Energy Meeting, March 17–22, Reno, Nevada.
- Magi M. 2005. *Personal communication*. Calgon Carbon Corporation. Feluy, Belgium.
- Malato S, Blanco J, Maldonado M I, Fernández-Ibáñez P, Campos A. 2000. *Optimising solar photocatalytic mineralisation of pesticides by adding inorganic oxidising species; application to the recycling of pesticide containers*. Applied Catalysis B: Environmental, 28, 163–174.
- Malato S, Blanco J, Fernández-Ibáñez P, Cáceres J. 2001a. Treatment of 2,4-Dichlorophenol by solar photocatalysis: comparison of coupled photocatalytic-active carbon vs. active carbon. Journal of Solar Energy Engineering, 123 (2), 138-142.
- Malato S, Maldonado M I, Blanco J. 2001b. *Descontaminación de aguas de lavado de envases de plaguicidas mediante fotocatalisis solar*. Ed. CIEMAT, Madrid.
- Malato S, Blanco J, Vidal A, Richter C. 2002. *Photocatalysis with solar energy at a pilot-plant scale: an overview*. Applied Catalysis B: Environmental, 37, pp.1-15.
- Malato S, Cáceres J, Fernández-Alba A R, Piedra L, Hernando M D, Agüera A, Vial J. 2003. *Photocatalytic treatment of diuron by solar photocatalysis: evaluation of main intermediates and toxicity*. Environmental Science and Technology, 37, pp. 2516-2524.
- Malato S, Blanco J, Maldonado M I, Fernandez P, Alarcon D, Collares M, Farinha J, Correia de Oliveira J. 2004. *Engineering of solar photocatalytic collectors*. Solar Energy, 77, pp. 513-524.
- Malato S, Maldonado M I. 2004. *The CADOX Project : A Coupled Advanced Oxidation-Biological Process For Recycling Of Industrial Wastewater Containing Persistent Organic Contaminants*. Applied Catalysis B: Environmental (News Brief) , 54 (1) , N2-N5.
- Maldonado M I, Gernjak W, Oller I, Malato S, Perrot J Y, Martín F, Vincent J P, Vincent M, Correia J. 2004. *Photo-Fenton based unit set-up and testing*. CADOX project Internal Report n° T330-ECOSYSTEM-01.
- Maldonado M I, Gernjak W, Oller I, Pérez-Estrada A, Carrión S, Malato S. 2005a. *Photo-Fenton based unit testing*. CADOX project Internal Report n° T330-CIEMAT-01.
- Maldonado M I, Gernjak W, Oller I, Pérez-Estrada A, Carrión S, Malato S, Muñoz J A. 2005b. *Specifications and detailed engineering*. CADOX project Internal Report n° T420-CIEMAT-01.
- Meier M A. 1997. *Eco-efficiency evaluation of waste gas purification systems in the chemical industry*. Doctoral thesis. Swiss Federal Institute of Technology Zurich. Diss. ETH No. 12259.
- Meier M A. 2005. *Personal communication*. Ciba Specialty Chemicals, Basel, Switzerland.
- Nielsen P, Hauschild M. 1998. *Product specific emissions from municipal solid waste landfills. Part I: Landfill model*. International Journal of Life Cycle Assessment 3 (3) pp. 158-168.
- Nijdam D, Blom J, Boere J A. 1999. *Environmental Life Cycle Assessment (LCA) of two advanced wastewater treatment techniques*. Studies in Surface Science and Catalysis 120 B, 763-775.
- Passarinho P, Farinha J. 2005. *TiO<sub>2</sub> based set-up & testing*. CADOX project Internal Report n° T320-INETI-01.

- Perrot J Y. 2004. *Personal communication*. Industrial applications manager, Trailigaz Compagnie Générale de l'Ozone. Garges-lès-Gonesse, France.
- Perrot J Y. 2005. *Specifications and detailed engineering*. CADOX project Internal Report n° T420-TRAILIGAZ-01.
- Peters M S, Timmerhaus K D. 1991. *Plant design and economics for chemical engineers*. McGraw-Hill, 4th Ed, New York.
- Rantik M. 1999. *Life Cycle Assessment of five batteries for electric vehicles under different charging regimes*. Chalmers University of Technology, Dept. of transportation and Logistics. Göteborg, Sweden.
- Ribera J. 2005. *Personal communication*. Laboratory manager, Pilagest, S.L. [www.pilagest.es](http://www.pilagest.es)
- Romero-Hernández O. 2004a. *To treat or not to treat? Applying chemical engineering tools and a life cycle approach to assessing the level of sustainability of a clean-up technology*. Green Chemistry 2004, 6, pp. 395-400.
- Romero-Hernández O. 2004b. *Applying life cycle tools and process engineering to determine the most adequate treatment process conditions. A tool in environmental policy*. International Journal of Life Cycle Assessment, 10 (5) pp. 355-363.
- Roskill Information Services. 1998. *The economics of activated carbon*. 6th edition. London, UK.
- Rydh, C J. 1999. *Environmental assessment of vanadium redox and lead-acid batteries for stationary energy storage*. Journal of Power Sources, 80, pp. 21-29.
- Saling P, Kicherer A, Dittrich-Krämer B, Wittlinger R, Zombik W, Schmidt I, Schrott W, Schmidt S. 2002. *Eco-efficiency by BASF: the method*. International Journal of Life Cycle Assessment, 7 (4), pp. 203-218.
- Sandén, B A, Jonasson K M, Kärlstrom M, Tillman A. 2005. *LCA of emerging technologies: a methodological framework*. LCM 2005 – Innovation by Life Cycle Management. International Conference. Book of abstracts, vol. 1. pp. 37-41.
- Sarrià V, Kenfack S, Malato S, Blanco J, Pulgarin C. 2005. *New helio-photocatalytic-photovoltaic hybrid system for simultaneous water decontamination and solar energy conversion*. Solar Energy, 79, pp. 353-359.
- Sattler C, Funken K H, Jung C, Monnerie N, de Oliveira L, Schäfer T. 2004. *Demonstration of photocatalytic waste water detoxification in textile industry*. Global Symposium on Recycling, Waste Treatment and Clean Technology, REWAS'04, Madrid., Spain.
- Schmidt W P. 2003. *Life Cycle Costing as part of Design for Environment. Environmental business cases*. International Journal of Life Cycle Assessment, 8 (3), pp. 167-174.
- Strickland G. 2005. *Personal communication*. Secretary General, European Lamp Companies Federation, Brussels, Belgium.
- Sundqvist J O. (Ed.).1997. *Life Cycle Assessment and Solid Waste*. Swedish Environmental Protection Agency. Stockholm, Sweden.
- TIGG Corporation. 2005. *CANSORB® RX – Polyethylene lined, activated carbon steel adsorbers*. [www.tigg.com/remediation\\_products/standard\\_products/liquid\\_phase/polyethyl\\_lined.html](http://www.tigg.com/remediation_products/standard_products/liquid_phase/polyethyl_lined.html)
- Tillman A M. 2000. *Significance of decision-making for LCA methodology*. Environmental Impact Assessment Review, 20, 1, pp. 113-123.
- U.S. Army Corps of Engineers. 2001. *Adsorption Design Guide*. Department of the Army, Washington DC.
- Udo de Haes H A, van Halen C J G (Eds.). 1997. *Results of the Dutch Platform 'LCA & Waste'*. Final Working Document, status report. PI Management Consultancy. The Hague.
- USEPA. 1973. *Process Design Manual for Carbon Adsorption*. U.S. Environmental Protection Agency, Technology Transfer, Washington DC.
- USEPA. 1996. *Fate, transport and transformation test guidelines. OPPTS 835.3200 Zahn-Wellens/EMPA Test*.

- Van Oers L, Huijbregts M, Huppes G, Koning A de, Suh S (Eds.). 2001. *LCA normalization data for the Netherlands 1997/1998, Western Europe 1995 and the World 1990 and 1995*. RIZA Lelystad and CML, Leiden University, Leiden, The Netherlands. [www.leidenuniv.nl/cml/lca2/index.html](http://www.leidenuniv.nl/cml/lca2/index.html)
- Vignes R P. *Use limited Life-Cycle Analysis for environmental decision making*. Chemical Engineering Progress, 97 (2), pp. 40-54.
- Vincent M. 2005. *Personal communication*. Ecosystem Environmental Services, S.A. Sant Andreu de Llavaneres, Spain.
- Weidema B. 2003. *Market information in Life Cycle Assessment*. Environmental Project n° 863 2003. Danish Environmental Protection Agency.
- WMO. 1992. *Scientific assessment of ozone depletion: 1991*. Report n° 25. Geneva.
- WMO. 1995. *Scientific assessment of ozone depletion: 1994*. Report n° 37. Geneva.
- WMO. 1998. *Scientific assessment of ozone depletion: 1998*. Report n° 44. Geneva.
- Zanitsch R H, Stenzel M H. 1978. *Economics of granular activated carbon water and wastewater treatment systems*. In: Cheremisinoff P N, Ellerbusch F. (Eds.). *Carbon adsorption handbook*. Ann Arbor Science, Michigan, USA.

## Appendix 1. Calculation of $Q_{UV}$ from pilot plant data

$Q_{UV}$  is the accumulated UV radiation needed by the photocatalytic reactor to reach a given level of pollutant removal (J/litre). This parameter is used in the inventory analysis as a basis for calculation of the CPC area needed by a plant treating Femac.  $Q_{UV}$  is calculated from the pilot plant experiments using the following equation:

$$Q_{UV} = \sum_{n_0}^{n_f} Q_{UV,n} = \sum_{n_0}^{n_f} \Delta t_n \cdot UV_n \cdot \frac{S_{CPC}}{V_T}; \quad \Delta t_n = t_n - t_{n-1} \quad (6.18)$$

Where:

$n$  is a sample taken during the experiment,

$\Delta t$  is the time interval between 2 samples (seconds),

$S_{CPC}$  is the pilot plant CPC aperture area (4,16 m<sup>2</sup>),

$UV_n$  is the average UV radiation measured by the radiometer during  $\Delta t$  (W/m<sup>2</sup>),

$V_T$  is the total pilot plant volume ( 75 litres)

Tables 6.A.1 and 6.A.2 show the data used for this calculation. The fourth column displays in the last row the accumulated  $Q_{UV}$  value, where the biodegradability goal is achieved, namely 120 and 40 mg DOC litre<sup>-1</sup> for photo-Fenton and heterogeneous photocatalysis respectively. As can be seen, approximately this parameter is 12 and 250 kJ litre<sup>-1</sup> for the respective treatments.

Table 6.A.1. Data extracted from heterogeneous photocatalysis degradation of Femac in pilot plant.

Irradiated samples	$UV_n$ (W/m <sup>2</sup> )	Irradiation time (min)	$Q_{UV}$ (kJ/litre)	DOC (mg/litre)
1		0.0	0	331.9
2	29.4	34.1	5.61	325.8
3	28.6	76.7	12.43	324.6
4	22.8	102.3	15.69	309.8
5	15.2	136.4	18.60	309.9
6	7.1	170.4	19.96	312.4
7		170.4	19.96	311.9
8	21.7	221.6	26.19	308.0
9	28.3	272.7	34.28	299.8
10	24.8	340.9	43.76	293.2
11	9.7	409.1	47.50	289.4
12		409.1	47.50	283.6
13	22.9	460.2	54.01	278.2
14	29.8	511.3	62.54	271.0
15	25.5	579.5	72.29	264.9
16	9.3	647.7	75.82	264.8
17		647.7	75.82	272.8
18	21.0	698.8	81.85	258.2
19	29.7	750.0	90.36	253.3
20	26.5	818.1	100.46	250.7
21	10.6	886.3	104.49	251.1
22		886.3	104.49	231.1
23	19.8	937.5	110.17	224.4
24	28.4	988.6	118.28	222.2

Table 6.A.2. Data extracted from photo-Fenton degradation of Femac in pilot plant.

Irradiated Samples	$UV_n$ (W/m <sup>2</sup> )	Irradiation time (min)	$Q_{UV}$ (kJ/litre)	DOC (mg/litre)
1	0.1	0	0.02	296.6
2	23.1	10	0.72	286.4
3	26.1	40	3.11	244.6
4	29.5	55	4.45	226.4
5	32	70	5.91	208.6
6	30.1	85	7.29	189.6
7	32	100	8.75	163.1
8	32.8	115	10.25	143.1
9	35.8	130	11.88	124.0

Source: PSA.

25	25.6	1056.8	128.05	208.6
26	12.1	1124.9	132.66	204.2
27		1124.9	132.66	190.4
28	19.4	1167.6	137.29	188.1
29	27.3	1218.7	145.10	178.9
30	26.1	1286.9	155.05	168.9
31	11.3	1355.0	159.34	163.0
32		1355.0	159.34	160.0
33	18.0	1406.2	164.43	155.2
34	26.8	1457.3	172.11	147.7
35	25.7	1525.5	181.91	136.8
36	9.8	1602.2	186.10	130.4
37		1602.2	186.10	129.2
38	15.0	1653.3	190.39	120.3
39	24.6	1704.5	197.43	113.5
40	22.5	1772.6	206.02	100.1
41	9.9	1840.8	209.81	86.50
42		1840.8	209.81	78.04
43	13.9	1891.9	213.78	76.33
44	20.5	1943.1	219.67	70.01
45	16.2	2011.3	225.85	60.54
46	5.9	2079.4	228.10	56.87
47		2079.4	228.10	53.86
48	15.2	2130.6	232.45	53.05
49	23.6	2181.7	239.19	47.74
50	22.9	2249.9	247.94	44.62
51	9.2	2318.1	251.43	42.91
52		2318.1	251.43	38.33
53	14.0	2369.2	255.45	39.17

Source: INETI.

## Appendix 2. Photovoltaic installation in a solar photocatalytic plant for wastewater treatment

Three different cases are evaluated in this appendix, depending on the slope of the roof where the CPCs have to be installed:

- 37°; this is the optimum case, since this is the local latitude of Almeria, and the tilt of the CPCs when they are installed on the ground.
- 0°; the case for a flat roof.
- 90°, the case for a vertical facade, assuming that it faces south.

Electricity is consumed by the plant to pump the water and for stirring. The former is a function of the CPC aperture area, as has been explained in section 6.3.3.1. As we move from 37°, the CPC area needed by the plant increases. According to Ecosystem (Vincent 2005), the total area would increase by 0%, 14% and 49% respectively. As a consequence, the pumping power will increase accordingly. The following table summarizes the electricity demand of the plant for all the tilt options. It is assumed that the overall efficiency of the photovoltaic (accounting for losses of the different elements) is 75% (ICAEN 2002)

Table 6.A.3. Electricity demand by the photocatalytic plant for different roof slopes.

Electricity demand	Fe (solar) 0°	Fe (solar) 37°	Fe (solar) 90°
$E_{PUMP}$ (kWh m <sup>-3</sup> ) <sup>a</sup>	0.73	0.64	0.96
Stirring (kWh m <sup>-3</sup> )	0.08	0.08	0.08
Total demand (kWh m <sup>-3</sup> )	0.81	0.72	1.03
Total demand per day (kWh) <sup>b</sup>	5.54	4.92	7.08
Total to be produced per day (kWh) <sup>c</sup>	7.38	6.56	9.44

<sup>a</sup> Calculated using eq. 3.

<sup>b</sup> 6.85 m<sup>3</sup> day<sup>-1</sup>.

<sup>c</sup> 75% efficiency.

Prior to the calculation of the number of modules needed, the global radiation at the plant site has to be determined. Table 6.A.4. shows the average daily radiation in Almería during the 12 months. The average of the 12 values has been chosen for the calculations.

Table 6.A.4. Average daily global radiation in the province of Almeria at 60° angle (kWh m<sup>-2</sup>).

J	F	M	A	M	J	J	A	S	O	N	D	Average
4,23	4,78	5,27	5,04	4,79	4,54	4,78	5,05	5,14	5,06	4,46	3,83	4,75

Source: IDAE 1996.

The solar modules considered are polycrystalline, with a power of 152 Wp<sup>17</sup> (Jungbluth 2004). The number of units needed  $N_M$  is calculated as follows:

<sup>17</sup> 1 Wp means that the cell delivers this power in optimal conditions, whereby the radiation density equals 1 kW/m<sup>2</sup> and the cell temperature equals 25 °C.

$$N_M = \frac{E_{DAY}}{kWp \cdot psh} \quad (6.19)$$

Where:

$E_{DAY}$  is the average daily electricity to be produced (kWh day<sup>-1</sup>),

$kWp$  is the peak power of the solar panels (0.172 kW), and

$psh$  is the number of daily peak sun hours, which equals the average number of kWh m<sup>-2</sup> day<sup>-1</sup> received at the site (4.75 hours day<sup>-1</sup>).

The result of applying equation 9 in the three cases (rounding up), as well as the peak power installed is shown in table 6.A.5. Once the peak power to install is defined, the storage system has to be also dimensioned. In order do so, the following hypothesis have been considered:

- The required autonomy of the batteries is set to 7 days.
- Their maximum discharge depth is 70%.
- Their voltage is 24 V.

The required battery capacity  $BC$ , measured in Ampere-hour (Ah) is calculated with these data using equation 6.20:

$$BC = \frac{E_{DAY} \cdot 1000 \cdot A}{Volt \cdot D_{MAX}} \quad (6.20)$$

Where:

$A$  is the autonomy (7 days)

$1,000$  is the conversion factor from kWh to Wh,

$Volt$  is the voltage of the batteries (24 V), and

$D_{MAX}$  is the maximum allowed discharge depth (70%).

The type of batteries chosen have a capacity of 750 Ah each unit. Therefore the number of units needed is calculated by dividing  $BC$  by 750 and rounding up. All the data is shown in table 6.A.5.

Table 6.A.5 Peak power to be installed in the photocatalytic plant for different roof slopes.

Electricity demand	Fe (solar) 0°	Fe (solar) 37°	Fe (solar) 90°
$N_P$ (units)	11	10	14
Installed power (kWp)	1.672	1.520	2.128
$BC$ (Ah)	3,077	2,734	3,934
Number of 750 Ah units	5	4	6

The cost of the whole installation is calculated in table 6.A.6, considering the following:



- As the Ecoinvent database does not include the unitary cost of the photovoltaic panels, the figure has been obtained from a similar model (module BP-3150-S, 150 Wp, 254 V multicontact), which costs 1,056 € unit<sup>-1</sup> (Inelsacontrols 2005).
- The cost of a 750 Ah Fulmen battery is 203€ unit<sup>-1</sup> (Inelsacontrols 2005).
- The cost of both the DC/AC converter as the regulator has been obtained from ICAEN (2002) as 700€ and 600€ respectively.
- Other cost components, such as installation, materials for connection and supports, etc., have been calculated as percentages of other groups of items, according to ICAEN (2002).

Table 6.A.6. Cost assessment of the photovoltaic system to be installed in the photocatalytic plant for different roof slopes.

Costs	Fe (solar) 0°	Fe (solar) 37°	Fe (solar) 90°
Solar modules	11,616	10,560	14,784
Batteries	1,015	812	1,218
Converter	700	700	700
Regulator	600	600	600
Subtotal photovoltaic material (€)	13,931	12,672	17,302
Material for connection and supports (8%)	1,114	1,014	1,384
Subtotal materials (€)	15,045	13,686	18,686
Materials installation (10%)	1,505	1,369	1,869
Subtotal installation (€)	16,550	15,054	20,555
Unforeseen (3%)	497	452	617
Project and industrial benefit (7%)	1,159	1,054	1,439
<b>Total (VAT excluded) (€)</b>	<b>18,205</b>	<b>16,560</b>	<b>22,610</b>

### Appendix 3. Estimation of solar photocatalytic plant dismantling cost

In this appendix an attempt is made to estimate the cost that would be incurred at the end-of-life phase of solar photocatalytic plants, applying either photo-Fenton or heterogeneous photocatalysis. These calculations are aimed at justifying that plant dismantling can be excluded from the LCC, as this phase implies a negligible cost when compared to initial investment or operation. If this can be justified for the solar plants, which are the most infrastructure-intensive, then it can be also justified from this example for the remaining alternatives.

The end-of-life phase implies costs related to dismantling of the entire solar field and equipment, in the form of personnel cost. These have been estimated by considering that 4 men can dismantle a 100 m<sup>2</sup> CPC solar field in a week (Vincent 2005); this leads to 4 x 8 x 5 = 160 man-hour, or 0.91 man-year, if 1,750 hours/man year are assumed. The unitary cost of personnel is 20,000 € man<sup>-1</sup> year<sup>-1</sup>, as considered in the cost assessment. 100 m<sup>2</sup> is the size of the photo-fenton plant, while for heterogeneous photocatalysis, which has 2,150 m<sup>2</sup> CPC, a proportional increase in personnel effort has been considered.

Table 6.A.7 shows the total amount of materials incorporated in the solar field of the photo-Fenton and heterogeneous photocatalysis plants, as calculated from the inventory analysis. Part of these materials have a market value, it is assumed then that a selective dismantling takes place, in which steel, glass and aluminium are separated. Plastics are not assumed to be recycled, but sent to a landfill. Finally, the concrete ground above which the solar field was installed is assumed to remain unaffected by dismantling.

Table 6.A.7. Total amount of materials incorporated in the solar field of photocatalytic detoxification plants.

Solar field materials (kg/plant)	Fe (solar)	Ti (solar)
Stainless steel	782	16,759
Galvanized steel	17	358
Aluminium	970	20,780
Glass	673	14,426
Polypropylene	140	3,002
Concrete	81,323	1,748,452

The unitary revenues from recycled materials (table 6.A.8) have been obtained from market statistics collected by the environmental service of the regional council of Barcelona (Diputació de Barcelona 2005), where a range (maximum and minimum value) of prices is given. The average price has been chosen for each material. The cost of transport and landfilling is the same used in the cost assessment of plant operation, of 0.02 € kg<sup>-1</sup> and 0.07 € kg<sup>-1</sup> respectively.

Table 6.A.8. Revenues considered for recycled materials.

Material	Revenue (€ kg <sup>-1</sup> )
Stainless steel	0,18
Aluminium	0,85
Glass	0,012

Source: Diputació de Barcelona 2005.

Finally, when the total dismantling cost is calculated, it has to be transformed to Net Present Value (NPV), as it is a cost incurred in the future. This is done by applying the Single Present Value (SPV) factor (Fuller and Petersen 1996). This factor is then multiplied by the cost in order to obtain its value discounted to present. SPV is calculated by equation 6.21:

$$SPV = \frac{1}{(1+r)^N} \quad (6.21)$$

Where:

$r$  is the interest (or discount) rate (6%), and

$N$  is the study period, at the end of which dismantling takes place (15 years).

The value obtained for SPV is 0.42. As a consequence, only 42% of the future cost of dismantling is computed as present value. Table 6.A.9 finally shows the calculation of all the costs above discussed and its discounting to present. Revenues from recycled materials are expressed as negative values, while costs are positive. As can be seen from the final result, 0.01€ m<sup>-3</sup> and 0.22 € m<sup>-3</sup> are the net present costs of dismantling the photo-Fenton and heterogeneous photocatalysis plants respectively. If these values are compared to the investment + operation cost, of 14 €/m<sup>3</sup> and 67 € m<sup>-3</sup>, calculated in the cost assessment (section 6.8), then it is justified that dismantling can be neglected, and it is assumed that it can also be neglected for the remaining alternatives under study.

Table 6.A.9. Calculation of dismantling cost of photocatalytic detoxification plants.

Cost calculation	Fe (solar)	Ti (solar)
Personnel	1,829	39,184
Revenues from recycled materials		
Steel (stainless + galvanized)	-144	-3,081
Aluminium	-824	-17,663
Glass	-8	-173
Transport	52	1,106
Landfill fee	10	211
Total (€)	914	19,584
Total (€ m <sup>-3</sup> )*	0,024	0,52
Net Present Value (€ m <sup>-3</sup> )	0,010	0,22

\* The plant has treated 2,500 m<sup>3</sup> year<sup>-1</sup> during 15 years of operating life.

## Appendix 4. Life Cycle Impact Assessment tables

### Characterisation

The following tables show the characterisation results for each alternative, disaggregated by sub-systems.

Table 6.A10. Characterisation results for solar-driven photo-Fenton coupled to biotreatment.

Impact categories	Units	Total	Solar field	Hydrogen peroxide	Chemicals transport	Electricity	MWWTP	Others*
GWP	kg CO <sub>2</sub> eq	5.8E+00	8.3E-01	1.9E+00	2.5E-01	3.5E-01	1.2E+00	1.2E+00
ODP	kg CFC-11 eq	3.1E-07	4.7E-08	1.8E-07	3.4E-08	1.4E-08	1.9E-08	2.5E-08
HTP	kg 1,4-DB eq	1.2E+01	4.1E+00	6.4E+00	1.4E-01	1.2E-01	1.1E+00	2.3E-01
FATP	kg 1,4-DB eq	1.3E+00	4.7E-01	4.1E-01	1.5E-02	2.1E-02	1.8E-01	1.6E-01
POFP	kg C <sub>2</sub> H <sub>4</sub> eq	9.3E-04	2.4E-04	2.8E-04	7.0E-05	7.5E-05	1.2E-04	1.4E-04
AP	kg SO <sub>2</sub> eq	1.9E-02	3.6E-03	6.4E-03	1.5E-03	1.9E-03	2.4E-03	3.6E-03
EP	kg PO <sub>4</sub> <sup>3-</sup> eq	1.9E-02	4.6E-04	6.2E-04	3.0E-04	9.5E-05	1.7E-02	3.0E-04
EC	MJ	7.1E+01	1.1E+01	3.8E+01	4.1E+00	7.7E+00	6.3E+00	4.0E+00
LU	m <sup>2</sup> y	2.5E-01	1.8E-01	2.5E-02	5.7E-03	7.1E-03	1.6E-02	1.8E-02

\* Includes sulphuric acid, sodium hydroxide, ferrous sulphate, water, iron sludge management and land use associated to the plant.

Table 6.A11. Characterisation results for solar-driven heterogeneous photocatalysis coupled to biotreatment.

Impact categories	Units	Total	Solar field	Electricity	MWWTP	Others*
GWP	kg CO <sub>2</sub> eq	2.9E+01	1.8E+01	8.8E+00	7.9E-01	1.3E+00
ODP	kg CFC-11 eq	1.4E-06	1.0E-06	3.6E-07	1.8E-08	2.5E-08
HTP	kg 1,4-DB eq	9.1E+01	8.7E+01	3.0E+00	1.0E+00	1.1E-01
FATP	kg 1,4-DB eq	1.1E+01	1.0E+01	5.2E-01	1.8E-01	9.6E-02
POFP	kg C <sub>2</sub> H <sub>4</sub> eq	7.2E-03	5.2E-03	1.9E-03	1.0E-04	4.7E-05
AP	kg SO <sub>2</sub> eq	1.3E-01	7.6E-02	4.8E-02	2.4E-03	1.1E-03
EP	kg PO <sub>4</sub> <sup>3-</sup> eq	2.8E-02	9.9E-03	2.4E-03	1.6E-02	2.0E-04
EC	MJ	4.4E+02	2.3E+02	1.9E+02	6.0E+00	3.0E+00
LU	m <sup>2</sup> y	3.4E+00	3.2E+00	1.8E-01	1.6E-02	1.0E-02

\* Includes TiO<sub>2</sub> production and transport, water, management of spent TiO<sub>2</sub> and land use associated to the plant.

Table 6.A12. Characterisation results ozonation coupled to biotreatment.

Impact categories	Units	Total	Oxygen	Cooling water	Electricity	MWWTP	Others*
GWP	kg CO <sub>2</sub> eq	1.9E+01	5.0E+00	1.1E+00	1.1E+01	1.4E+00	9.9E-01
ODP	kg CFC-11 eq	7.5E-07	2.1E-07	6.1E-08	4.4E-07	1.9E-08	3.0E-08
HTP	kg 1,4-DB eq	7.6E+00	1.7E+00	1.0E+00	3.5E+00	1.1E+00	2.4E-01
FATP	kg 1,4-DB eq	1.3E+00	3.0E-01	1.9E-01	6.2E-01	1.8E-01	3.9E-02
POFP	kg C <sub>2</sub> H <sub>4</sub> eq	3.9E-03	1.1E-03	3.6E-04	2.3E-03	1.2E-04	7.8E-05
AP	kg SO <sub>2</sub> eq	9.5E-02	2.7E-02	5.9E-03	5.8E-02	2.4E-03	2.0E-03
EP	kg PO <sub>4</sub> <sup>3-</sup> eq	2.3E-02	1.4E-03	5.8E-04	2.9E-03	1.8E-02	2.6E-04
EC	MJ	3.7E+02	1.1E+02	2.0E+01	2.3E+02	6.4E+00	6.5E+00
LU	m <sup>2</sup> y	5.2E-01	1.0E-01	1.5E-01	2.1E-01	1.6E-02	4.0E-02

\* Includes sodium hydroxide, transport of chemicals, and land use associated to the plant.

Table 6.A13. Characterisation results for lamp-driven photo-Fenton coupled to biotreatment.

Impact categories	Units	Total	Hydrogen peroxide	Electricity	MWWTP	Others*
GWP	kg CO <sub>2</sub> eq	1.2E+01	1.9E+00	7.0E+00	1.2E+00	1.5E+00
ODP	kg CFC-11 eq	5.5E-07	1.8E-07	2.9E-07	1.9E-08	6.3E-08
HTP	kg 1,4-DB eq	1.0E+01	6.4E+00	2.4E+00	1.1E+00	5.1E-01
FATP	kg 1,4-DB eq	1.2E+00	4.1E-01	4.1E-01	1.8E-01	1.9E-01
POFP	kg C <sub>2</sub> H <sub>4</sub> eq	2.1E-03	2.8E-04	1.5E-03	1.2E-04	2.3E-04
AP	kg SO <sub>2</sub> eq	5.2E-02	6.4E-03	3.8E-02	2.4E-03	5.6E-03
EP	kg PO <sub>4</sub> <sup>3-</sup> eq	2.0E-02	6.2E-04	1.9E-03	1.7E-02	6.4E-04
EC	MJ	2.1E+02	3.8E+01	1.5E+02	6.3E+00	1.0E+01
LU	m <sup>2</sup> y	2.5E-01	2.5E-02	1.4E-01	1.6E-02	6.4E-02

\* Includes lamp production, sulphuric acid, sodium hydroxide, ferrous sulphate, water, transport of chemicals, iron sludge management and land use associated to the plant.

Table 6.A14. Characterisation results for granular activated carbon adsorption.

Impact categories	Units	Total	GAC regeneration	GAC production	MWWTP	Others*
GWP	kg CO <sub>2</sub> eq	3.8E+01	2.9E+01	6.5E+00	3.3E-01	2.1E+00
ODP	kg CFC-11 eq	4.2E-06	3.3E-06	6.5E-07	1.3E-08	2.9E-07
HTP	kg 1,4-DB eq	1.0E+01	5.8E+00	1.9E+00	9.8E-01	1.4E+00
FATP	kg 1,4-DB eq	5.6E-01	1.7E-01	8.6E-02	1.7E-01	1.3E-01
POFP	kg C <sub>2</sub> H <sub>4</sub> eq	3.7E-03	2.3E-03	8.4E-04	6.4E-05	5.2E-04
AP	kg SO <sub>2</sub> eq	1.3E-01	1.0E-01	1.5E-02	1.2E-03	1.4E-02
EP	kg PO <sub>4</sub> <sup>3-</sup> eq	2.5E-02	2.1E-02	9.8E-04	3.0E-04	2.7E-03
EC	MJ	6.6E+02	5.1E+02	1.2E+02	3.3E+00	3.6E+01
LU	m <sup>2</sup> y	2.1E-01	5.7E-02	6.8E-02	1.3E-02	6.7E-02

\* Includes electricity, land use associated to the plant, transport of GAC to the plant, transport of spent GAC to the regeneration furnace and transport of regenerated GAC to the plant.

Table 6.A15. Characterisation results obtained in the sensitivity analysis on granular activated carbon adsorption.

Impact categories	Units	Total	GAC regeneration	GAC production	MWWTP	Others*
GWP	kg CO <sub>2</sub> eq	1.1E+01	5.5E+00	3.3E+00	3.3E-01	2.1E+00
ODP	kg CFC-11 eq	7.6E-07	3.9E-07	6.7E-08	1.3E-08	2.9E-07
HTP	kg 1,4-DB eq	5.9E+00	1.6E+00	2.0E+00	9.8E-01	1.4E+00
FATP	kg 1,4-DB eq	5.2E-01	7.3E-02	1.4E-01	1.7E-01	1.3E-01
POFP	kg C <sub>2</sub> H <sub>4</sub> eq	2.2E-03	6.3E-04	1.0E-03	6.4E-05	5.2E-04
AP	kg SO <sub>2</sub> eq	1.2E-01	8.1E-02	2.2E-02	1.2E-03	1.4E-02
EP	kg PO <sub>4</sub> <sup>3-</sup> eq	2.3E-02	1.9E-02	1.0E-03	3.0E-04	2.7E-03
EC	MJ	1.6E+02	6.9E+01	4.9E+01	3.3E+00	3.6E+01
LU	m <sup>2</sup> y	2.2E-01	3.4E-02	1.0E-01	1.3E-02	3.7E-02

\* Includes electricity, land use associated to the plant, transport of GAC to the plant, transport of spent GAC to the regeneration furnace and transport of regenerated GAC to the plant.

Table 6.A.16. Characterisation results for Improved solar-driven photo-fenton coupled to biotreatment, 37° roof slope.

Impact categories	Units	Total	Solar field*	Operation
GWP	kg CO <sub>2</sub> eq	5.0E+00	4.1E-01	4.6E+00
ODP	kg CFC-11 eq	2.7E-07	1.9E-08	2.5E-07
HTP	kg 1,4-DB eq	1.0E+01	2.5E+00	7.8E+00
FATP	kg 1,4-DB eq	1.1E+00	3.7E-01	7.7E-01
POFP	kg C <sub>2</sub> H <sub>4</sub> eq	7.4E-04	1.3E-04	6.1E-04
AP	kg SO <sub>2</sub> eq	1.6E-02	2.5E-03	1.4E-02
EP	kg PO <sub>4</sub> <sup>3-</sup> eq	1.9E-02	3.8E-04	1.9E-02
EC	MJ	6.1E+01	9.0E+00	5.2E+01
LU	m <sup>2</sup> y	1.2E-01	2.4E-02	9.4E-02

\* Including photovoltaic system.

Table 6.A.17. Characterisation results for Improved solar-driven photo-fenton coupled to biotreatment, 0° roof slope.

Impact categories	Units	Total	Solar field*	Operation
GWP	kg CO <sub>2</sub> eq	5.0E+00	4.7E-01	4.6E+00
ODP	kg CFC-11 eq	2.8E-07	2.3E-08	2.5E-07
HTP	kg 1,4-DB eq	1.1E+01	2.8E+00	7.8E+00
FATP	kg 1,4-DB eq	1.2E+00	4.2E-01	7.7E-01
POFP	kg C <sub>2</sub> H <sub>4</sub> eq	7.6E-04	1.4E-04	6.1E-04
AP	kg SO <sub>2</sub> eq	1.7E-02	2.9E-03	1.4E-02
EP	kg PO <sub>4</sub> <sup>3-</sup> eq	1.9E-02	3.8E-04	1.9E-02
EC	MJ	6.2E+01	1.0E+01	5.2E+01
LU	m <sup>2</sup> y	1.2E-01	2.7E-02	9.4E-02

\* Including photovoltaic system.

Table 6.A.18. Characterisation results for Improved solar-driven photo-fenton coupled to biotreatment, 90° roof slope.

Impact categories	Units	Total	Solar field*	Operation
GWP	kg CO <sub>2</sub> eq	5.2E+00	6.1E-01	4.6E+00
ODP	kg CFC-11 eq	2.9E-07	3.2E-08	2.5E-07
HTP	kg 1,4-DB eq	1.1E+01	3.6E+00	7.8E+00
FATP	kg 1,4-DB eq	1.3E+00	5.4E-01	7.7E-01
POFP	kg C <sub>2</sub> H <sub>4</sub> eq	8.0E-04	1.9E-04	6.1E-04
AP	kg SO <sub>2</sub> eq	1.7E-02	3.6E-03	1.4E-02
EP	kg PO <sub>4</sub> <sup>3-</sup> eq	1.9E-02	5.8E-04	1.9E-02
EC	MJ	6.4E+01	1.2E+01	5.2E+01
LU	m <sup>2</sup> y	1.3E-01	3.3E-02	9.4E-02

\* Including photovoltaic system.

Table 6.A.19. Characterisation results for Improved ozonation coupled to biotreatment.

Impact categories	Units	Total	Oxygen	Cooling water	Electricity	MWWTP	Others*
GWP	kg CO <sub>2</sub> eq	1.4E+01	3.3E+00	7.3E-01	8.1E+00	1.4E+00	9.4E-01
ODP	kg CFC-11 eq	5.6E-07	1.4E-07	4.1E-08	3.4E-07	1.9E-08	2.4E-08
HTP	kg 1,4-DB eq	5.8E+00	1.1E+00	7.0E-01	2.7E+00	1.1E+00	2.0E-01
FATP	kg 1,4-DB eq	1.0E+00	2.0E-01	1.3E-01	4.8E-01	1.8E-01	3.2E-02
POFP	kg C <sub>2</sub> H <sub>4</sub> eq	2.9E-03	7.2E-04	2.4E-04	1.8E-03	1.2E-04	6.5E-05
AP	kg SO <sub>2</sub> eq	7.1E-02	1.8E-02	4.0E-03	4.5E-02	2.4E-03	1.6E-03
EP	kg PO <sub>4</sub> <sup>3-</sup> eq	2.2E-02	9.0E-04	3.9E-04	2.2E-03	1.8E-02	2.0E-04
EC	MJ	2.8E+02	7.3E+01	1.3E+01	1.8E+02	6.4E+00	5.5E+00
LU	m <sup>2</sup> y	3.9E-01	6.8E-02	9.9E-02	1.7E-01	1.6E-02	3.9E-02

\* Includes sodium hydroxide, transport of chemicals, and land use associated to the plant.

## Normalisation and weighting

The following tables include, for each alternative, the results of normalisation. The normalised impact indicators are then summed up in the last row, leading to the weighted score. Since the normalisation results are only summed, all impact categories are equally weighted with a factor of 1.

Table 6.A.20. Normalised and weighted results for all baseline alternatives including sensitivity analysis on GAC adsorption.

Impact categories	Units	Fe (solar)	Ti (solar)	O3	Fe (lamp)	GAC	GAC (S.A.)
GWP	y	1.2E-12	6.0E-12	3.9E-12	2.4E-12	7.9E-12	2.3E-12
ODP	y	3.8E-15	1.7E-14	9.0E-15	6.6E-15	5.1E-14	9.1E-15
HTP	y	1.6E-12	1.2E-11	1.0E-12	1.4E-12	1.3E-12	7.8E-13
FATP	y	2.5E-12	2.2E-11	2.6E-12	2.4E-12	1.1E-12	1.0E-12
POFP	y	1.1E-13	8.8E-13	4.7E-13	2.6E-13	4.5E-13	2.7E-13
AP	y	6.6E-13	4.4E-12	3.2E-12	1.8E-12	4.4E-12	4.0E-12
EP	y	1.5E-11	2.3E-11	1.8E-11	1.6E-11	2.0E-11	1.8E-11
EC	y	2.5E-12	1.5E-11	1.3E-11	7.3E-12	2.3E-11	5.6E-12
LU	y	7.6E-14	1.0E-12	1.6E-13	7.6E-14	5.4E-14	6.7E-14
Total	y	2.4E-11	8.3E-11	4.3E-11	3.2E-11	5.9E-11	3.2E-11

Table 6.A.21. Normalised and weighted results for solar-driven photo-Fenton coupled to biotreatment, considering different  $UV_G$  values.

Impact categories	Units	$UV_G$ (W/m <sup>2</sup> )					
		5	10	15	20	25	30
GWP	y	1.8E-12	1.4E-12	1.3E-12	1.2E-12	1.1E-12	1.1E-12
ODP	y	5.7E-15	4.4E-15	4.0E-15	3.7E-15	3.6E-15	3.5E-15
HTP	y	3.1E-12	2.1E-12	1.7E-12	1.5E-12	1.4E-12	1.4E-12
FATP	y	5.2E-12	3.3E-12	2.7E-12	2.4E-12	2.3E-12	2.1E-12
POFP	y	2.1E-13	1.4E-13	1.2E-13	1.1E-13	1.0E-13	9.8E-14
AP	y	1.1E-12	8.1E-13	7.0E-13	6.4E-13	6.1E-13	5.9E-13
EP	y	1.6E-11	1.6E-11	1.5E-11	1.5E-11	1.5E-11	1.5E-11
EC	y	4.2E-12	3.0E-12	2.6E-12	2.4E-12	2.3E-12	2.3E-12
LU	y	2.0E-13	1.2E-13	8.9E-14	7.2E-14	6.4E-14	5.8E-14
Total	y	3.2E-11	2.6E-11	2.5E-11	2.4E-11	2.3E-11	2.3E-11

Table 6.A.22. Normalised and weighted results for improved alternatives.

Impact categories	Units	O3 75%	Fe (solar) 37°	Fe (solar) 0°	Fe (solar) 90°
GWP	y	3.0E-12	1.0E-12	1.0E-12	1.1E-12
ODP	y	6.7E-15	3.3E-15	3.3E-15	3.4E-15
HTP	y	7.7E-13	1.4E-12	1.4E-12	1.5E-12
FATP	y	2.0E-12	2.3E-12	2.4E-12	2.6E-12
POFP	y	3.5E-13	8.9E-14	9.2E-14	9.7E-14
AP	y	2.4E-12	5.5E-13	5.7E-13	5.9E-13
EP	y	1.7E-11	1.5E-11	1.5E-11	1.5E-11
EC	y	9.8E-12	2.2E-12	2.2E-12	2.3E-12
LU	y	1.2E-13	3.6E-14	3.7E-14	3.9E-14
Total	y	3.6E-11	2.3E-11	2.3E-11	2.3E-11



# CHAPTER 7.

## Overall Discussion and Conclusions

---

*“A conclusion is simply the place where you got tired of thinking”.*

*Proverb*

### CONTENTS

7.1. Discussion.....	248
7.1.1. Streamlined vs. detailed Life Cycle and cost assessment of AOPs for wastewater treatment.....	248
7.1.1.1. Identification of critical aspects in the baseline scenario.....	249
7.1.1.2. Identification of critical aspects in the solar scenario.....	250
7.1.1.3. Comparative assessment of alternatives.....	251
7.1.1.4. Cost assessment.....	252
7.1.2. “Greenness” of AOPs according to LCA results.....	252
7.1.3. Suitability of LCA as a tool for Green Chemistry.....	253
7.1.4. LCC as complement to LCA in Green Chemistry.....	254
7.2. Conclusions.....	256
7.2.1. General conclusions.....	256
7.2.2. Specific conclusions.....	257

This final chapter is mainly constituted by a discussion on the applicability of LCA as a tool for Green Chemistry, based on the experience gained through the case studies on AOPs put into practice in chapters 5 and 6. Finally, the main conclusions of the thesis are outlined.

## 7.1. Discussion

The discussion deals with several aspects included in the objectives of the thesis: the suitability of LCA as a tool for Green Chemistry, its integration with LCC, and the reliability of laboratory-derived LCA studies. All these issues are discussed using as a starting point the case studies on AOPs developed in chapters 5 and 6, as well as the theoretical background of previous chapters.

### 7.1.1. Streamlined vs. detailed Life Cycle and cost assessment of AOPs for wastewater treatment

This section aims at discussing the reliability of streamlined LCA studies applied to chemical products and processes at the first stage of research and development, that is, when most of the information available is that generated by laboratory tests. The discussion is carried out by checking the results obtained in chapter 5 (streamlined LCA) with those of chapter 6 (detailed LCA). However, comparing these case studies with each other must be done with care, due to the following reasons:

- The alternatives under study are not the same. On the one hand, some alternatives in chapter 5 are not assessed in chapter 6, namely ozone in combination with UV-A light, as well as heterogeneous photocatalysis in combination with hydrogen peroxide or in combination with photo-Fenton, either using lamps or sunlight. On the other hand, activated carbon adsorption is not assessed in chapter 5.
- The wastewater treated is also different. In chapter 5 a paper pulp bleaching effluent containing a mixture of organochlorinated compounds is considered, while in chapter 6 a synthetic wastewater containing a single compound, Femac, is treated.
- The functional unit is different in each study: in chapter 5 a target of 15% DOC removal per m<sup>3</sup> wastewater is defined, while in chapter 6 there is not a common percentage of DOC removal, since the functional unit is based on the concept of biodegradability: the goal is to remove DOC from 1 m<sup>3</sup> wastewater until it can be further treated in a conventional sewage plant. As a consequence, the DOC removal target is different for each treatment.
- AOPs assessed in chapter 6 are coupled to biological treatment, while in chapter 5 pre-treatment and post-treatment of the wastewater, whether biological or not, is excluded.
- The experimental conditions in which the AOPs are tested in each chapter are also different. In chapter 5 all AOPs are carried out in acidic conditions (pH 3), while in chapter 6 pH is only adjusted for photo-Fenton. In addition, the amount of reagents used is also different. For example, heterogeneous photocatalysis uses 2 g litre<sup>-1</sup> TiO<sub>2</sub> in chapter 5, while in chapter 6 the dose is only 200 mg litre<sup>-1</sup>.

As a consequence, the results of chapter 6 can not be strictly considered as a standard to which chapter 5 is checked. It could be argued that AOPs in chapter 5 and 6 should have been assessed under equivalent conditions. However, as the research and development process advances from laboratory scale to commercial application, the progressive increase in knowledge, data available, etc., could advise to change the scenarios, boundaries and conditions under which the system is analysed, in order to make the analysis closer to real work conditions. Having said this, in the sections below the results and conclusions obtained in chapter 5 are discussed under the light of chapter 6 findings, in order to evaluate to what extent they match.

### 7.1.1.1. Identification of critical aspects in the baseline scenario

In chapter 5 the baseline scenario is defined as that in which all AOPs use electricity from the grid to run either the UV lamps or the ozoniser. In order to compare the results of this scenario with those of chapter 6, only photo-Fenton and ozonation can be discussed, since these are the only alternatives using lamps or ozone in chapter 6.

Chapter 5 identifies electricity consumption as the most critical aspect for all AOPs in the baseline scenario. While in lamp-driven AOPs electricity is related to illumination of the reactor, in ozonation it is related to the ozoniser. The impact of power consumption by the ozoniser is in accordance with chapter 6, since as can be seen in table 7.1, in most impact categories the relative contributions of this sub-system to the overall impacts are critical, and very similar in both case studies. With regard to photo-Fenton, it can be seen in table 7.1 that in both case studies power consumption by the lamps is identified as an important aspect, but in chapter 5 it is responsible of almost 100% of the impacts, thus becoming negligible the contribution of hydrogen peroxide, something which is in conflict with conclusions in chapter 6, where this chemical is identified as a relevant aspect for lamp-driven photo-Fenton.

Table 7.1. Contribution of electricity consumption to the environmental profile of ozonation and lamp-driven photo-Fenton in chapters 5 and 6.

Sub-system	GWP	ODP	HTP	FATP	POFP	AP	EP	EC	LU
Electricity contributions, ozonation									
Chapter 6	56%	58%	47%	47%	58%	61%	12%	62%	41%
Chapter 5	64%	59%				63%	57%	64%	
Electricity contributions, lamp-driven photo-Fenton									
Chapter 6	60%	53%	23%	34%	70%	73%	9%	74%	57%
Chapter 5	98%	96%				99%	98%	98%	

The most likely reason for these conflicting results with regard to lamp-driven photo-Fenton is the lack of optimization of the photochemical reactor used in the laboratory experiments described in chapter 5; only a small fraction of the UV photons emitted by the lamp reach the solution, leading to a low energy efficiency that makes electricity consumption figures overdimensioned, and the environmental impact of hydrogen peroxide therefore becomes relatively irrelevant. In future studies, this could be adjusted by measuring the real number of photons reaching the reactor, by means of actinometry or an UV light meter, and assuming a lamp-reactor efficiency representative of an industrial facility.

Table 7.2. Contribution of chemicals consumption to the environmental profile of ozonation and lamp-driven photo-Fenton in chapters 5 and 6.

Sub-system	GWP	ODP	HTP	FATP	POFP	AP	EP	EC	LU
Oxygen contributions, ozonation									
Chapter 6	26%	27%	22%	22%	27%	29%	6%	29%	19%
Chapter 5	33%	31%				33%	30%	33%	
Hydrogen peroxide contributions, lamp-driven photo-Fenton									
Chapter 6	16%	32%	62%	35%	13%	12%	3%	18%	10%
Chapter 5	2%	3%				2%	1%	1%	
Iron sulphate contributions, lamp-driven photo-Fenton									
Chapter 6	0%	0%	0%	0%	0%	0%	0%	0%	0%
Chapter 5	0%	0%				0%	0%	0%	

Concerning consumption of chemicals, in chapter 5 it is concluded that only oxygen contributes in a significant manner, namely in the ozonation alternative. This is in accordance with conclusions of chapter 6, as can be seen in table 7.2, but it has been already mentioned that in chapter 6 hydrogen peroxide is also found to be an important hotspot of lamp-driven photo-Fenton, mainly in the toxicity impact indicators, which were excluded in chapter 5. Finally, in both case studies iron sulphate – the photo-Fenton catalyst – appears to have a negligible contribution.

Table 7.3. Contribution of transports to the environmental profile of ozonation and lamp-driven photo-Fenton in chapters 5 and 6.

Sub-system	GWP	ODP	HTP	FATP	POFP	AP	EP	EC	LU
Transport contributions, ozonation									
Chapter 6	1%	3%	2%	2%	1%	1%	1%	1%	1%
Chapter 5	3%	10%				4%	13%	2%	
Transport contributions, lamp-driven photo-Fenton									
Chapter 6	2%	6%	1%	1%	3%	3%	1%	2%	2%
Chapter 5	0%	1%				0%	1%	0%	

Finally, transport of the chemical products to the plant site is found in chapter 5 to be negligible, except in the ozonation alternative, due to the large amount of oxygen consumed by this process. In chapter 6, on the other hand, transport of chemicals appears also as a negligible operation in environmental terms, not only for photo-Fenton, but also for ozonation. The reason of the conflicting results with regard to transport of oxygen is the inefficiency related to the laboratory tests. In chapter 5, from the experimental data, a figure of 54 kg oxygen per kg ozone produced is calculated, while in chapter 6 this figure decreases to 10 kg oxygen per kg ozone, a typical value for an industrial ozoniser.

Finally, several sub-systems were excluded in the streamlined LCA, due to lack of data, or because they were assumed to be negligible in environmental terms. In the detailed LCA, however, those sub-systems were included:

- Acidification of the wastewater (in the photo-Fenton alternative),
- Production of lamps,
- Production of cooling water for the ozoniser,
- Post-treatment of the wastewater (neutralization, biological treatment), and
- Catalyst sludge management.

From the results obtained in chapter 6, it can be seen that none of these sub-systems contribute critically to the overall impacts of ozonation and lamp-driven photo-Fenton, with the exception of the biological treatment, in the particular impact category of eutrophication. Nevertheless, this contribution in eutrophication is not related to the assessed processes themselves, but to the pollutant being treated, Femac, which contains nitrogen in its molecule.

#### 7.1.1.2. Identification of critical aspects in the solar scenario

In chapters 5 and 6 the environmental consequences of using solar energy as a source of photons have been assessed for Heterogeneous photocatalysis and photo-Fenton. In chapter 5 the inventory analysis only included the amount of reagents and catalyst use ( $\text{TiO}_2$ ,  $\text{H}_2\text{O}_2$  and  $\text{FeSO}_4$ ) as well as transport of these to the plant site. On the other hand, a deeper study is carried out in chapter 6, including in addition of chemicals and transports, the following sub-systems:

- Pumping,
- Infrastructure,
- Acidification of the wastewater (in the photo-Fenton alternative),
- Post-treatment of the wastewater (neutralization, biological treatment), and
- Catalyst separation and sludge management.

Therefore, the system boundaries in chapter 5 are very narrow, excluding some sub-systems which are found to be relevant in chapter 6, specially for heterogeneous photocatalysis (table 7.4), namely infrastructure production, and electricity consumption (pumping and catalyst separation by microfiltration). On the other hand, the impact of TiO<sub>2</sub> use, which is responsible of the overall impact of this alternative in chapter 5, appears as a negligible sub-system in chapter 6. Something similar happens to photo-Fenton, although in this case the main chemical used, hydrogen peroxide, is found in both studies to be a critical aspect.

Table 7.4. Contribution of selected sub-systems to the environmental profile of solar-driven heterogeneous photocatalysis in chapters 5 and 6.

Sub-system	GWP	ODP	HTP	FATP	POFP	AP	EP	EC	LU
<b>Infrastructure contributions, solar-driven heterogeneous photocatalysis</b>									
Chapter 6	62%	71%	95%	93%	72%	60%	35%	53%	24%
Chapter 5									
<b>Electricity contributions, solar-driven heterogeneous photocatalysis</b>									
Chapter 6	31%	26%	3%	5%	26%	38%	9%	45%	5%
Chapter 5									
<b>Titanium dioxide contributions, solar-driven heterogeneous photocatalysis</b>									
Chapter 6	1%	4%	1%	2%	2%	1%	0%	1%	0%
Chapter 5	99%	99%				99%	98%	99%	

### 7.1.1.3. Comparative assessment of alternatives

In chapter 5 the following conclusions are reached:

- a) Solar-driven photo-Fenton is the best environmental option among the ones studied.
- b) Photochemical AOPs reduce their environmental impact between 90 and 99% when they shift from lamps to solar energy.
- c) Solar-driven AOPs are better options than any AOP using a conventional energy source.

Conclusion a) is in agreement with chapter 6, since as can be seen in table 7.5, in both case studies solar-driven photo-Fenton is identified as the “front-runner” alternative. Nevertheless, conclusions b) and c) are in contradiction with chapter 6. On the one hand, in chapter 6 lamp-driven photo-Fenton is compared to solar-driven photo-Fenton, and though actually in most impact indicators the solar option entails a lower impact, the latter is never reduced by 90% to 99% as stated in conclusion b), but from 7% to 66% depending on the indicator, and less if the comparison is based on the weighted LCIA results (table 7.5). Finally, with regard to conclusion c), chapter 6 has demonstrated that the use of solar energy is not always the best environmental option, as shown by solar-driven heterogeneous photocatalysis, entailing a considerably higher impact than ozonation or lamp-driven photo-Fenton, mainly due to production of infrastructure and

energy requirements for pumping and microfiltration, two sub-systems excluded in the case study developed in chapter 5.

Table 7.5. LCIA weighted results for several AOPs assessed in chapters 5 and 6.

Results	Ti (solar)	O3	Fe (lamp)	Fe (solar)
Weighted LCIA results, absolute values				
Chapter 6	8,38E-11	4,30E-11	3,20E-11	2,39E-11
Chapter 5	1,43E-12	6,38E-10	5,09E-11	8,48E-13
Weighted LCIA results, relative values				
Chapter 6	100%	51%	38%	29%
Chapter 5	0,22%	100,00%	7,98%	0,13%

#### 7.1.1.4. Cost assessment

In table 7.6 the costs calculated in chapter 5 and 6 are shown. They can not be directly compared, as the functional unit is different, as well as the cost components included. What can be examined, however, is whether or not both approaches match in their respective ranking of alternatives. The answer appears to be no, as the order, from cheaper to more expensive would be Fe (solar) – Ti (solar) – Fe (lamp) – O3 in chapter 5, and Fe (lamp) – Fe (solar) – O3 – Ti (solar) in chapter 6.

Table 7.6. Cost (€ m<sup>-3</sup>) for several AOPs assessed in chapters 5 and 6.

Results	Ti (solar)	O3	Fe (lamp)	Fe (solar)
Chapter 6	67	15	12	14
Chapter 5	4	91	6	1

The cost assessment carried out in chapter 5 can not be considered an LCC, as only the inputs quantified in the inventory analysis are computed as costs. Chapter 6 has shown that several life cycle cost components not directly related to material and energy flows, such as investment, labor, and maintenance are key issues, while others, for example plant decommissioning, are negligible. From these facts, the cost assessment in chapter 5 can not be used as a proxy for life cycle cost, but as a proxy for operation costs in which labor and maintenance costs are excluded.

#### 7.1.2. “Greenness” of AOPs according to LCA results

“Greenness” of AOPs has been discussed in chapter 3, by cross-checking several of these technologies with the 12 principles of Green Chemistry. The main conclusion of that qualitative exercise is that little can be said on the relative “greenness” of any technology when qualitative judgements are the only criteria. In this chapter, after having carried out two LCA case studies on AOPs, quantitative environmental and life-cycle based criteria can be added to the discussion.

It is still maintained here, as it has been in chapter 3, that a process, product or activity is not inherently “green”, but “greener” with respect to others. It is in this context, namely comparing things, that LCA can tell something about the performance of AOPs. From the results of the LCA case studies, the following has been found out on the relative “greenness” of AOPs:

- The differences in environmental impact between AOP technologies can be very relevant, which means that some of them are “greener” than others.
- When AOPs as a group are compared to a conventional technology, in particular to activated carbon adsorption assuming regeneration of the latter, they do not clearly appear as a “greener” group of technologies, unless the discussion is on particular options within this group.
- The two case studies have highlighted the “greenness” of solar-driven photo Fenton, either with regard to the remaining AOPs or to activated carbon adsorption.

Then, the results of the LCA case studies advise not to speak about AOPs as a whole, but about particular technologies, and also about specific applications, as these results are not intended to be universal, and could change when the type of wastewater, or other parameters, are changed.

### 7.1.3. Suitability of LCA as a tool for Green Chemistry

The 12 principles presented in chapter 2 constitute the basic pillars of Green Chemistry, that is, a series of ideas for chemists and chemical engineers to start thinking on how to develop environmentally friendly products and processes. In practice, however, progress towards “greenness” can not be measured just by checking compliance with Green Chemistry principles; the example on AOPs has been very illustrative: solar-driven heterogeneous photocatalysis, as designed and tested in the CADOX project, could be considered as an environmentally friendly technology, complying with several Green Chemistry principles, such as using a non-toxic catalytic reagent, using the sun as a source of photons, using ambient pressure and temperature, etc. Nevertheless, when this alternative is assessed by means of LCA to treat Femac, it appears as the worst option among those assessed in the study, even among options not complying with those principles.

This thesis has tried to emphasize the need for Green Chemistry to use quantitative tools to support decision making, and has suggested LCA as a suitable tool for that purpose, since it attempts to capture the direct and indirect environmental consequences of a given product or process design, and benefits from an increasing international acceptance, endorsed by several ISO standards. The case studies developed on the subject of AOPs constitute a good example of the information that LCA is able to provide on environmental performance, namely:

- Identify the origin of environmental impacts in a product or process,
- Compare alternative products or processes,
- Assess potential benefits derived from measures for environmental improvement,
- Assess the influence of several parameters on the environmental performance of the alternatives under study, by means of sensitivity analyses and breakeven analyses.

As has been shown in this thesis, the tool can be applied at several stages of the research and development process:

- Laboratory scale,
- Pilot plant, and
- Demonstration plant/full-scale

The case study on AOPs developed in chapter 5 is an example of LCA being applied, on a streamlined basis, to a chemical process tested in the laboratory. The possibility of using the tool in this context is considered very important, since the laboratory scale is the core of Green Chemistry, that is, where chemical products and processes are first conceived and evaluated. It is at this scale that the inherent properties of a product or process must be defined, being LCA an useful tool to evaluate the environmental consequences of design strategies. However, in spite of being applicable, two main limitations have been identified when carrying out laboratory-derived LCAs:

- Lack of optimization, and
- Definition of system boundaries (processes included and excluded).

Chemical processes are first tested in the laboratory in order to evaluate their effectiveness, rather than their efficiency. Efficiency issues are dealt with later, at the pilot- and full-scale by process engineers. As a consequence, the evaluation of chemical processes by exclusively using laboratory data implies overestimating material and energy flows, unless some kind of adjustment is made. Overestimation makes processes or life-cycle stages more important than they really are, thus making other processes or life-cycle stages appear as not important, when they might be. In addition of this, overestimation can also constitute a problem when comparing alternatives. Another key issue is related to the definition of the system boundaries, and consists on deciding which processes are included and excluded from the inventory analysis. Sometimes processes are excluded because they are assumed to be irrelevant. In other cases, it is the laboratory scale itself that prevents from taking into account issues which are identified as relevant, but not yet defined, or hardly quantifiable from laboratory data, such as material requirements for building a CPC solar field, or the management of waste generated by the process. In order to properly solve this, it is necessary to wait until up-scaling data is available. For these reasons, a laboratory-derived LCA involves a considerable uncertainty, and is suggested as a screening tool, that is, as a means for gathering preliminary environmental information in which categoric conclusions should be avoided.

On the other hand, the case study developed in chapter 6 consists of a mixture of pilot-plant, demonstration-plant and commercial-plant scale. It can be seen that the data available at this scale allows for a much more detailed and reliable study, in which the potential of LCA as a tool is clearly exhibited. From a Green Chemistry perspective, assessing chemical processes at this level is also important, since the fact that commercial plants already exist for the technology assessed, does not mean that the latter must be considered mature. At this level, although the fundamental characteristics of the process are set, there is still a considerable margin for Eco-design and optimization of chemical processes, as has been shown with ozonation and solar-driven photo-Fenton, by assessing the potential benefits from several design measures.

As final comment, the fact that LCA is suggested as a suitable tool for Green Chemistry, does not mean that LCA must replace other existing tools. As has been concluded in chapter 2, the tool to be used depends on the questions to answer, and in most cases, not a single tool, but a toolbox will be needed. The intention of this thesis has been to highlight the need for Green Chemistry to use tools, and contribute to the acceptance of the life cycle approach to measure "greenness".

#### 7.1.4. LCC as complement to LCA in Green Chemistry

Assessing the sustainability of products and processes requires the development of a life cycle-based toolbox including at least one tool for every pillar of sustainability: environmental, economic and social. At present, the only standardized



tool within this toolbox is LCA, although LCC seems to be on the way to becoming the chosen tool for economic assessment. As LCC is progressively accepted, it is expected to be used as a standard addition to LCA, due to the fact that economic information is crucial for decision making, specially in the business context.

From a Green Chemistry perspective, the case studies on AOPs have revealed that carrying out a complete LCC of emergent technologies on the basis of laboratory tests seems very complex, due to the lack of data on costs different than those related to material and energy flows, namely investment, labor, maintenance, etc., which are difficult to obtain at this level. Rather than an LCC, laboratory-derived cost assessments should be considered as a first approximation to operation costs. As a consequence, a detailed LCC is only feasible when information is available on full-scale application, unless the technology under study is mature and background information is available in handbooks, etc., as it is the case for activated carbon adsorption in chapter 6.

Concerning integration with LCA, in chapter 4 the basic requirements for harmonization of both tools have been presented and discussed, as well as some methods, not only for integrating the tools but also for displaying the results obtained, by means of indexes and diagrams. It is the opinion of the author that reducing the environmental and economic information to a single score expressed in monetary units must be avoided, due to the difficulties and ethical considerations related to monetization of environmental impacts. In this thesis two alternative approaches have been used: in chapter 5 a two-dimension diagram has been used to represent impacts and costs, while in chapter 6 an Eco-efficiency Index has been defined. Nevertheless, it is suggested that environmental and economic results should also be kept separate, as different criteria to support decision making.

## 7.2. Conclusions

As a result of the work developed in this thesis, the following general and specific conclusions have been reached.

### 7.2.1. General conclusions

- ✓ Green chemistry constitutes a good theoretical framework for pollution prevention in the development of chemical products and processes. The 12 guiding principles offered by this framework are useful as fundamental approaches motivating and inspiring chemists and chemical engineers, but the relative “greenness” of a chemical product or process can not be evaluated solely on the basis of compliance with these principles, due to their qualitative nature. It is thus concluded that in order to assess the relative “greenness” of chemical product or process alternatives, quantitative analytical tools are needed.
- ✓ LCA, up to date the only standardized method for environmental assessment, is suggested as a suitable tool for Green Chemistry, due to its holistic approach, in which all operations upstream and downstream of the chemical reaction are included, by quantifying all relevant inputs and emissions to the environment associated, regardless of when or where they occur. Hence, this thesis supports that LCA can be used to assess the environmental implications of innovative chemical products and processes designed to comply with Green Chemistry principles.
- ✓ Application of LCA can be carried out at several stages during the research and development phase of chemical technologies, as demonstrated by this thesis: from the most basic, namely the laboratory scale, to the most advanced, namely commercial application. As the research and development process advances from the laboratory scale to commercial application, the reliability of LCA studies increase, but on the other hand the degrees of freedom decrease and consequently the opportunities for environmental improvement. The laboratory scale is considered as the core of Green Chemistry, that is, where chemical products and processes are first conceived. For this reason, the possibility of applying LCA at this scale to evaluate the environmental consequences of design strategies must be taken into account, though bearing in mind the limitations of such studies.
- ✓ Results and conclusions obtained by means of streamlined LCA studies based exclusively on laboratory-derived data do not necessarily match the results and conclusions obtained when a more complete and detailed LCA is performed at a later stage of chemical technology development. The following reasons have been identified as causing potential discordance:
  - Lack of optimization of the conditions in which the chemical process takes place in laboratory tests.
  - Excluding operations or life cycle phases which are hardly quantifiable or representative of full-scale when evaluated from laboratory tests.
- ✓ In addition to these factors, as the research and development phase advances, the progressive increase in knowledge, data available, etc., could advise to change the scenarios, boundaries and conditions under which the technology is analysed, in order to make the analysis closer to real work conditions, thus enlarging the potential gap with regard to a preliminary laboratory-derived LCA.
- ✓ In order to increase the reliability of streamlined LCAs based on laboratory-derived data, it is necessary to carry them out by always questioning whether or not the factors explained above (optimization, inclusion of relevant operations, procedures and conditions in which the process is performed at the bench scale) are representative of a

full-scale application, trying to increase this representativeness as much as possible. Nevertheless, it is clear that studies applying this streamlining approach will not in most cases have the quality of detailed studies carried out in advanced stages of technology development. For this reason, it is suggested that laboratory-derived LCAs should be used with caution, as a means of obtaining preliminary environmental information and avoiding categorical conclusions.

- ☑ Detailed LCA studies applied to chemical technologies require at least the first commercial applications or demonstration projects to be already implemented, in order to supply with enough quality data to perform the LCA. Although technology is in this case assessed in a more advanced stage of development, still a margin for environmental improvement exists, in which more focus is put on engineering measures rather than in inherent technology properties. LCA has been demonstrated in this thesis to be a useful tool to assess the potential environmental benefits of such measures.
- ☑ LCC seems to be a very suitable complement to LCA in order to capture the economic consequences of chemical products and processes through their life cycle. The key for integrating these tools lies in considering the same functional unit, system boundaries, and taking into consideration costs not directly related to material and energy flows, such as investment or labor. The latter seems to be difficult to consider in laboratory-derived LCAs, thus cost assessments from laboratory data are approximations to operation costs, rather than complete LCCs.

### 7.2.2. Specific conclusions

The specific conclusions of the thesis refer to the detailed LCA-LCC case study developed on the subject of AOPs for treating Femac (alfa-methyl-phenylglycine), in which the following alternatives have been assessed:

- Solar-driven heterogeneous photocatalysis coupled to biological treatment,
- Solar-driven photo-Fenton coupled to biological treatment,
- Lamp-driven photo-Fenton coupled to biological treatment,
- Ozonation coupled to biological treatment, and
- Activated carbon adsorption (reference technology).

The main conclusions reached on environmental impacts (taking Global Warming Potential as an example) and costs can be summarised as follows:

- ☑ Heterogeneous photocatalysis involves the highest environmental impact (29 kg CO<sub>2</sub> eq m<sup>-3</sup> Femac wastewater) from the set of alternatives, even taking into account that solar energy is used as a source of photons. This is due to the large CPC field required and the energy requirements for pumping and microfiltration. The lowest environmental impact is achieved in most indicators by solar-driven photo-Fenton (6 kg CO<sub>2</sub> eq m<sup>-3</sup>).
- ☑ The environmental impact of ozonation (19 kg CO<sub>2</sub> eq m<sup>-3</sup>) and lamp-driven photo-Fenton (12 kg CO<sub>2</sub> eq m<sup>-3</sup>) falls in between that of the alternatives above mentioned. Lamp-driven photo-Fenton obtains better results than ozonation in several indicators, although it must be borne in mind that the former has been assessed without specific experimental data.

- ☑ When compared to a conventional technology, namely activated carbon adsorption (11 kg CO<sub>2</sub> eq m<sup>-3</sup>), the only AOP appearing as more environmentally friendly is solar-driven photo-Fenton. It must be borne in mind, however, that carbon adsorption has been assessed assuming regeneration of the carbon, whereby only regeneration losses must be replaced. Although it has not been assessed in the thesis, if spent carbon was incinerated instead of regenerated, the relative performance of AOPs would significantly improve.
- ☑ With regard to costs, all the AOPs assessed, except heterogeneous photocatalysis (67 € m<sup>-3</sup>) are economically competitive with regard to activated carbon adsorption (15 € m<sup>-3</sup>). The cheapest option is lamp-driven photo-Fenton (12 € m<sup>-3</sup>), followed by solar-driven photo-Fenton (14 € m<sup>-3</sup>) and ozonation (15 € m<sup>-3</sup>).

The main processes or sub-systems contributing to the environmental impact of the AOPs assessed are the following:

- Solar CPC field infrastructure,
  - Electricity consumption for pumping, production of ozone and lamp irradiation,
  - Hydrogen peroxide and oxygen consumption.
- ☑ The environmental impact of solar-driven AOPs increase in locations where less UV radiation is available, due to the progressive increase in CPC aperture area and pumping requirements. However, solar-driven photo-Fenton is still preferable from an environmental point of view to all the remaining alternatives, even in northern Europe.
  - ☑ Concerning costs, they sharply increase as less UV radiation is available. In locations where the yearly average radiation is below 15 W-UV m<sup>-2</sup>, ozonation and carbon adsorption are more economically attractive than solar-driven photo-Fenton. On the other hand, in order for the latter to become cheaper than lamp-driven photo-Fenton, at least 30 W-UV m<sup>-2</sup> are required, a figure unavailable in Europe.
  - ☑ A reduction of 10% to 15% in environmental impact can be expected in the solar-driven photo-Fenton alternative if the CPC field is installed on the roof of the industrial facility, along with a photovoltaic system for autonomous supply of electricity. Life-cycle land use, on the other hand, is reduced by 50%. These measures increase the cost up to 20%, but this is due to the investment cost of the photovoltaic system; if conventional power supply is considered, the cost remains unchanged.
  - ☑ A reduction of about 25% in environmental impact can be expected in the ozonation alternative if the ozone transfer efficiency is increased from 50% to 75%, by means of recirculating ozone in the off-gas of the contact column to a second contact column. This environmental improvement comes along with a 13% reduction in overall cost.
  - ☑ The differences in environmental impact among the different AOPs and with regard to a conventional technology prevents from speaking about AOPs as a group of “green” technologies for wastewater treatment, unless the discussion is on particular options for treating particular wastewaters. Therefore, it is the opinion of the author that a case-by-case examination is needed, and it is hoped that the life cycle approach developed in this thesis can be used in future studies, thereby contributing to support decisions on how to achieve a sustainable chemistry.